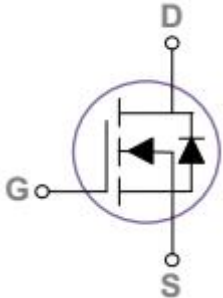
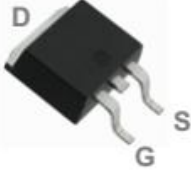

N-Channel Power MOSFET

<p>General Features</p> <ul style="list-style-type: none"> ● $V_{DS} = 60V, I_D = 17A$ $R_{DS(ON)} < 75\ m\Omega @ V_{GS} = 10V$ $R_{DS(ON)} < 90\ m\Omega @ V_{GS} = 4.5V$ ● Improved dv/dt capability ● High density cell design for ultra low Rdson ● Good stability and uniformity with high EAs ● Excellent package for good heat dissipation 	 <p>Schematic diagram</p>
<p>Applications</p> <ul style="list-style-type: none"> ● Power switching application ● Hard switched and high frequency circuits ● Motor drive 	 <p>TO252 Pin Configuration</p>

Absolute Maximum Ratings ($T_C = 25^\circ C$ unless otherwise noted)

Parameter	Symbol	Limit	Unit
Drain-Source Voltage	V_{DS}	60	V
Gate-Source Voltage	V_{GS}	± 20	V
Drain Current-Continuous ($T_C = 25^\circ C$)	$I_D(25^\circ C)$	17	A
Drain Current-Continuous ($T_C = 100^\circ C$)	$I_D(100^\circ C)$	12	A
Pulsed Drain Current	I_{DM}	44	A
Maximum Power Dissipation	P_D	25	W
Derating factor		0.2	W/ $^\circ C$
Operating Junction and Storage Temperature Range	T_J, T_{STG}	-50 To 150	$^\circ C$

Thermal Characteristic

Thermal Resistance, Junction-to-Case ^(Note 2)	$R_{\theta JC}$	3.3	°C/W
--	-----------------	-----	------

Electrical Characteristics ($T_C=25^\circ\text{C}$ unless otherwise noted)

Parameter	Symbol	Condition	Min	Typ	Max	Unit
Off Characteristics						
Drain-Source Breakdown Voltage	BV_{DSS}	$V_{GS}=0V, I_D=250\mu A$	60	-	-	V
Zero Gate Voltage Drain Current	I_{DSS}	$V_{DS}=60V, V_{GS}=0V, T_J=25^\circ\text{C}$	-	-	1	μA
Gate-Body Leakage Current	I_{GSS}	$V_{GS}=\pm 20V, V_{DS}=0V$	-	-	± 100	nA
On Characteristics (Note 3)						
Gate Threshold Voltage	$V_{GS(th)}$	$V_{DS}=V_{GS}, I_D=250\mu A$	1.2	1.8	2.5	V
Drain-Source On-State Resistance	$R_{DS(on)}$	$V_{GS}=10V, I_D=6A$	-	60	75	m Ω
		$V_{GS}=4.5V, I_D=3A$	-	70	90	
Forward Transconductance	g_{FS}	$V_{DS}=10V, I_D=3A$	-	4	-	S
Dynamic Characteristics (Note 4)						
Input Capacitance	C_{iss}	$V_{DS}=15V, V_{GS}=0V,$ $F=1.0\text{MHz}$	-	500	725	PF
Output Capacitance	C_{oss}		-	45	65	PF
Reverse Transfer Capacitance	C_{rss}		-	16	30	PF
Switching Characteristics (Note 4)						
Turn-on Delay Time	$t_{d(on)}$	$V_{DD}=30V, I_D=1A$ $V_{GS}=10V, R_G=3.3\Omega$	-	2.9	6	nS
Turn-on Rise Time	t_r		-	9.5	18.	nS
Turn-Off Delay Time	$t_{d(off)}$		-	18.4	35	nS
Turn-Off Fall Time	t_f		-	5.3	10	nS
Total Gate Charge	Q_g	$V_{DS}=48V, I_D=6A,$ $V_{GS}=10V$	-	9.3	13	nC
Gate-Source Charge	Q_{gs}		-	2.1	3	nC
Gate-Drain Charge	Q_{gd}		-	1.8	4	nC
Drain-Source Diode Characteristics						
Diode Forward Voltage ^(Note 3)	V_{SD}	$V_{GS}=0V, I_S=1A, T_J=25^\circ\text{C}$	-	-	1.0	V
Diode Forward Current ^(Note 2)	I_S	$V_G=V_D=0V$	-	-	11	A
Reverse Recovery Time	t_{rr}	$V_{GS}=30V, I_S=1A, T_J=25^\circ\text{C}$	-	23.2	-	nS
Reverse Recovery Charge	Q_{rr}	$di/dt = 100A/\mu s$ ^(Note 3)	-	14.3	-	nC
Forward Turn-On Time	t_{on}	Intrinsic turn-on time is negligible (turn-on is dominated by LS+LD)				

Notes:

1. Repetitive Rating: Pulse width limited by maximum junction temperature.
2. Surface Mounted on FR4 Board, $t \leq 10$ sec.
3. Pulse Test: Pulse Width $\leq 300\mu s$, Duty Cycle $\leq 2\%$.
4. Guaranteed by design, not subject to production

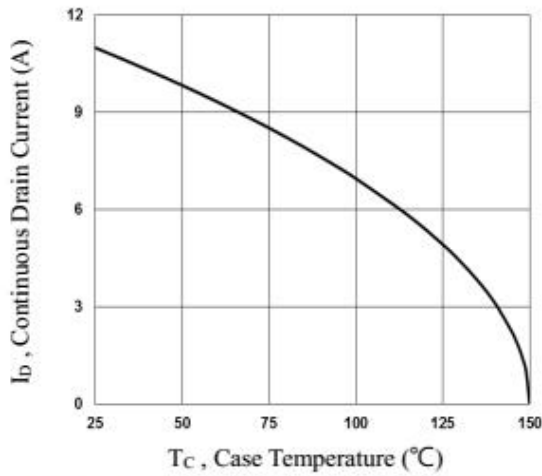
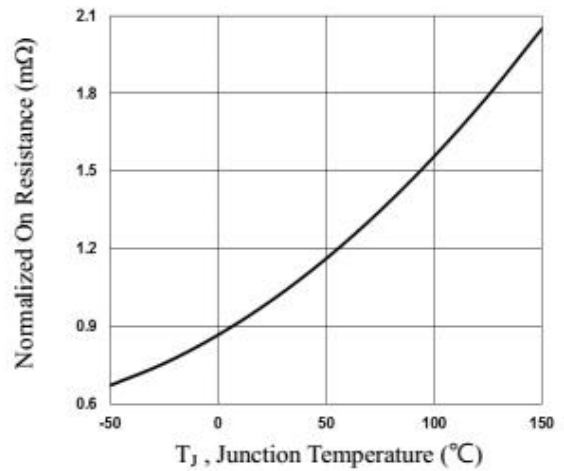
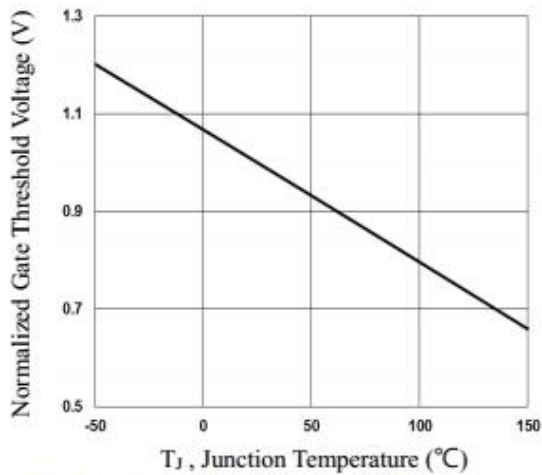
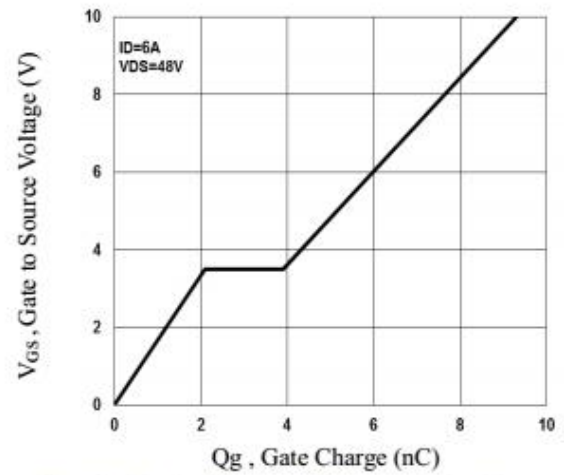
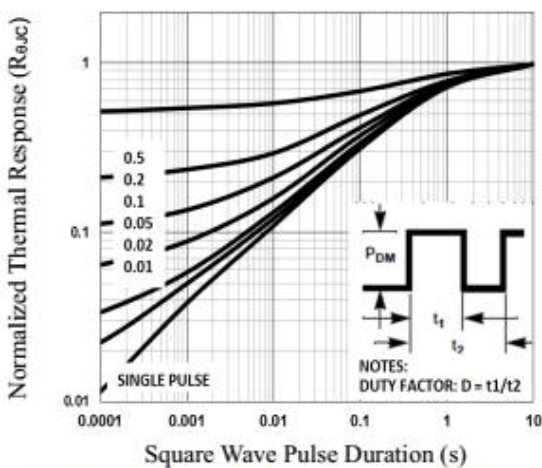
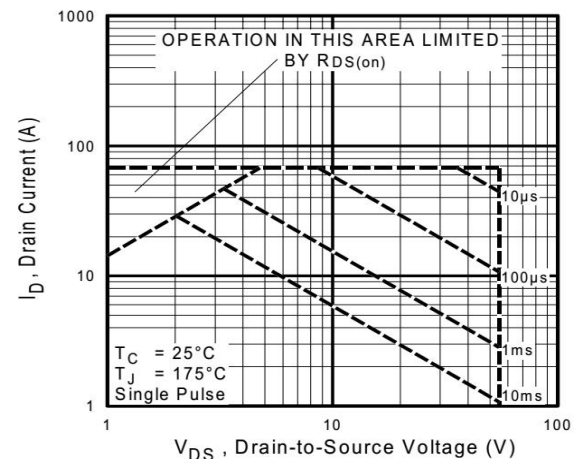
Typical Electrical and Thermal Characteristics (Curves)

Fig.1 Continuous Drain Current vs. T_c

Fig.2 Normalized $R_{DS(on)}$ vs. T_j

Fig.3 Normalized V_{th} vs. T_j

Fig.4 Gate Charge Characteristics

Fig.5 Normalized Transient Impedance

Fig.6 Maximum Safe Operation Area

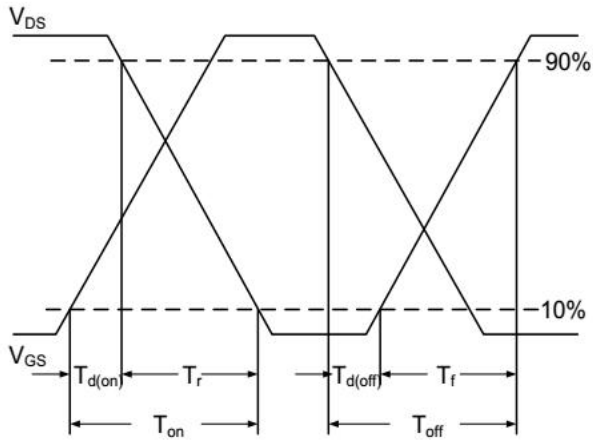

Fig.7 Switching Time Waveform

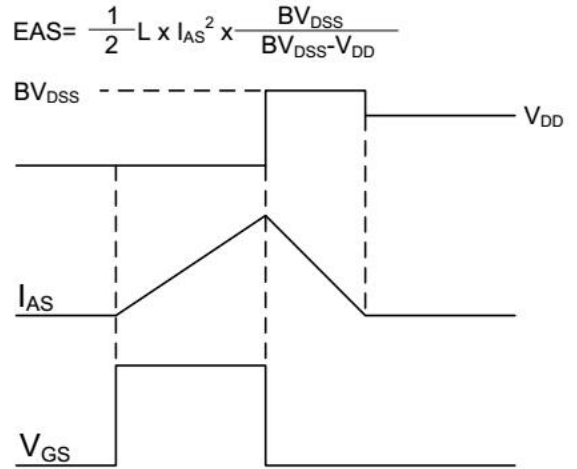
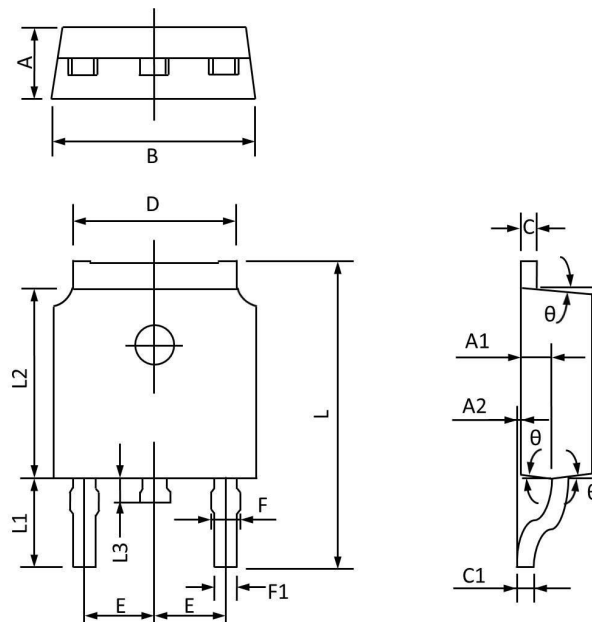

Fig.8 EAS Waveform

TO252 Package Information

Symbol	Dimensions In Millimeters		Dimensions In Inches	
	Min	Max	Min	Max
A	2.20	2.40	0.087	0.094
A1	0.91	1.11	0.036	0.044
A2	0.00	0.15	0.000	0.006
B	6.50	6.70	0.256	0.264
C	0.46	0.580	0.018	0.230
C1	0.46	0.580	0.018	0.030
D	5.10	5.46	0.201	0.215
E	2.186	2.386	0.086	0.094
F	0.74	0.94	0.029	0.037
F1	0.660	0.860	0.026	0.034
L	9.80	10.40	0.386	0.409
L1	2.9REF		0.114REF	
L2	6.00	6.20	0.236	0.244
L3	0.60	1.00	0.024	0.039
θ	3°	9°	3°	9°

单击下面可查看定价，库存，交付和生命周期等信息

[>>Slkor\(萨科微\)](#)