

# TLE7233G

SPIDER - 4 channel low side driver with limp home

Automotive Power



## Table of Contents

	<b>Table of Contents</b> .....	2
<b>1</b>	<b>Overview</b> .....	3
<b>2</b>	<b>Block Diagram</b> .....	5
2.1	Voltage and current naming definition .....	6
<b>3</b>	<b>Pin Configuration</b> .....	7
3.1	Pin Assignment .....	7
3.2	Pin Definitions and Functions .....	7
<b>4</b>	<b>General Product Characteristics</b> .....	9
4.1	Absolute Maximum Ratings .....	9
4.2	Functional Range .....	10
4.3	Thermal Resistance .....	10
<b>5</b>	<b>Power Supply</b> .....	11
5.1	Limp Home Mode .....	12
<b>6</b>	<b>Power Stages</b> .....	13
6.1	Input Circuit .....	13
6.2	Inductive Output Clamp .....	14
6.3	Timing Diagrams .....	15
6.4	Electrical Characteristics Power Stages .....	16
<b>7</b>	<b>Protection Functions</b> .....	18
7.1	Over Load Protection .....	18
7.2	Over Temperature Protection .....	18
7.3	Reverse Polarity Protection .....	18
7.4	Electrical Characteristics Protection .....	19
<b>8</b>	<b>Diagnostic Features</b> .....	20
8.1	Open Load Diagnosis timing .....	20
8.2	Electrical Characteristics Diagnostic .....	21
<b>9</b>	<b>Serial Peripheral Interface (SPI)</b> .....	22
9.1	SPI Signal Description .....	22
9.2	Daisy Chain Capability .....	23
9.3	SPI Protocol .....	24
9.4	Timing Diagrams .....	26
9.5	Electrical Characteristics SPI .....	27
<b>10</b>	<b>Application Information</b> .....	29
<b>11</b>	<b>Package Outlines</b> .....	30
<b>12</b>	<b>Revision History</b> .....	31



## 1 Overview

### Features

- 4 channel low side relay driver
- 8 bit SPI for diagnostics and control
- SPI providing Daisy Chain Capability
- Limp Home functionality
- Very wide range for digital Supply Voltage
- Four input pins provide flexible and straightforward PWM operation
- Stable behavior at Under Voltage
- Green Product (RoHS compliant)
- AEC Qualified

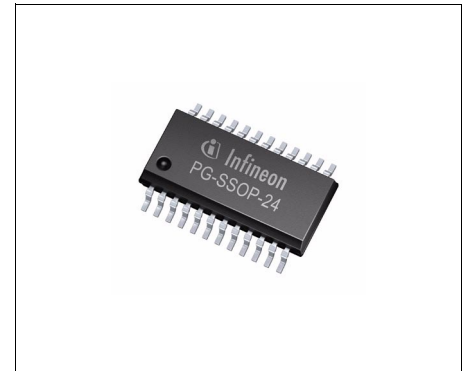

PG-SSOP-24-5

**Table 1 Product Summary**

Digital supply voltage	$V_{DD}$	3.0 V ... 5.5 V
Analog supply voltage	$V_{DDA}$	4.5 V ... 5.5 V
ON State resistance at $T_j = 150^\circ\text{C}$ for each channel	$R_{DS(ON)}$	2.2 $\Omega$
Nominal load current	$I_{L(nom,min)}$	390 mA
Overload switch off threshold	$I_{D(OVL,max)}$	950 mA
Output leakage current per channel at 25 °C	$I_{D(STB,max)}$	1 $\mu\text{A}$
Drain to Source clamping voltage	$V_{DS(AZ)}$	41 V
SPI clock frequency	$f_{SCLK}$	5 MHz

### Diagnostic Features

- Latched diagnostic information via SPI
- Over temperature monitoring
- Over load detection in ON state
- Open load detection in OFF state

Type	Package	Marking
TLE7233G	PG-SSOP-24-5	TLE7233G

**Protection Functions**

- Short circuit
- Over load
- Over temperature
- Electrostatic discharge (ESD)

**Application**

- All types of resistive, inductive and capacitive loads
- Especially designed for driving relays in automotive applications

**Description**

The TLE7233G is a four channel low-side relay switch (1  $\Omega$  per channel) in PG-SSOP-24-5 package providing embedded protective functions. It is especially designed as a relay driver for automotive applications. The 8 bit serial peripheral interface (SPI) is provided for control and diagnostics of the device and the loads. The SPI interface provides daisy-chain capability.

The TLE7233G is equipped with four input pins that can be individually routed to the output control of their corresponding channel and therefore offer complete flexibility in design and PCB layout. The input multiplexer is controlled via SPI.

A limp home pin (LHI) provides a simple use of the input pins; this enables a direct connection between the input pins and their corresponding outputs. The limp home function works under  $V_{DDA}$  in order to ensure functionality even with a missing digital supply.

The device provides many diagnostics of the load enabling both open load and short circuit detection. The SPI diagnostic bits indicate any eventual latched fault condition.

Each output stage is protected against short circuit. In case of over load, the affected channel switches off. Temperature sensors are available for each channel in order to protect the device against over temperature.

The power transistors are made of N-channel vertical power MOSFETs. The inputs CMOS compatible referenced to Ground. The device is monolithically integrated in Smart Power Technology.

## 2 Block Diagram

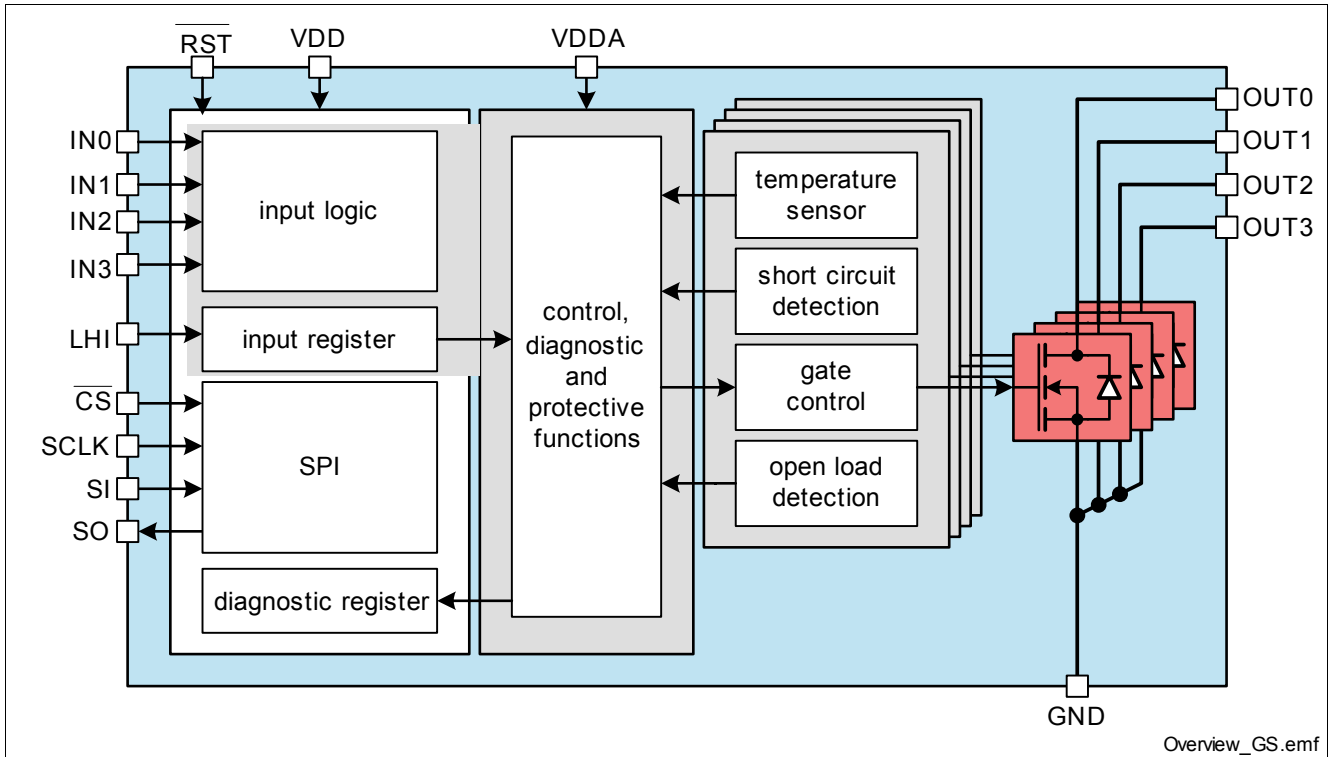

Figure 1 Block Diagram

## 2.1 Voltage and current naming definition

Following figure shows all the terms used in this datasheet, with associated convention for positive values.

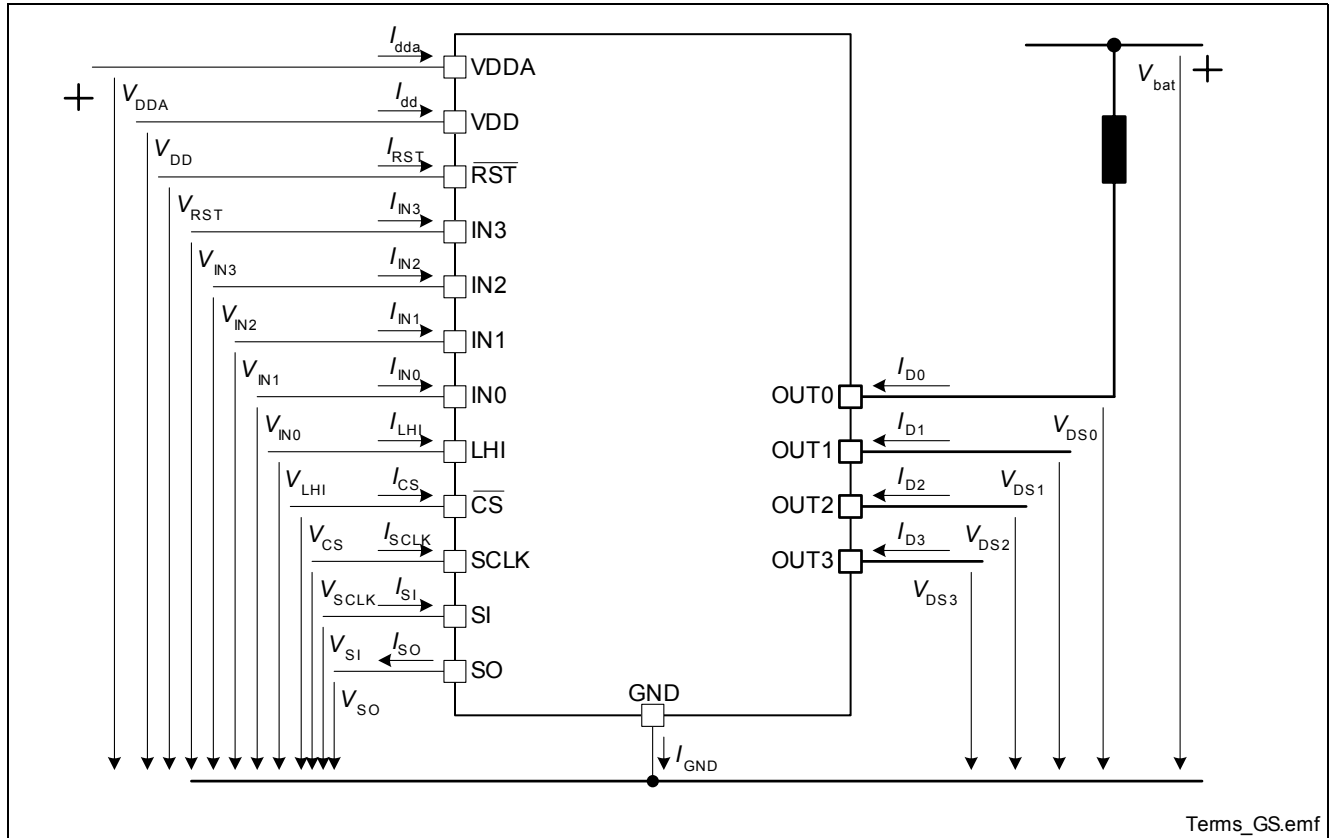

Figure 2 Terms

In all tables of electrical characteristics is valid: Channel related symbols without channel number are valid for each channel separately (e.g.  $V_{DS}$  specification is valid for  $V_{DS0} \dots V_{DS3}$ ).

All SPI register bits are marked as follows: **PARAMETER** (e.g. **IN0**). In SPI register description, the values in bold letters (e.g. **0**) are default values.

### 3 Pin Configuration

#### 3.1 Pin Assignment

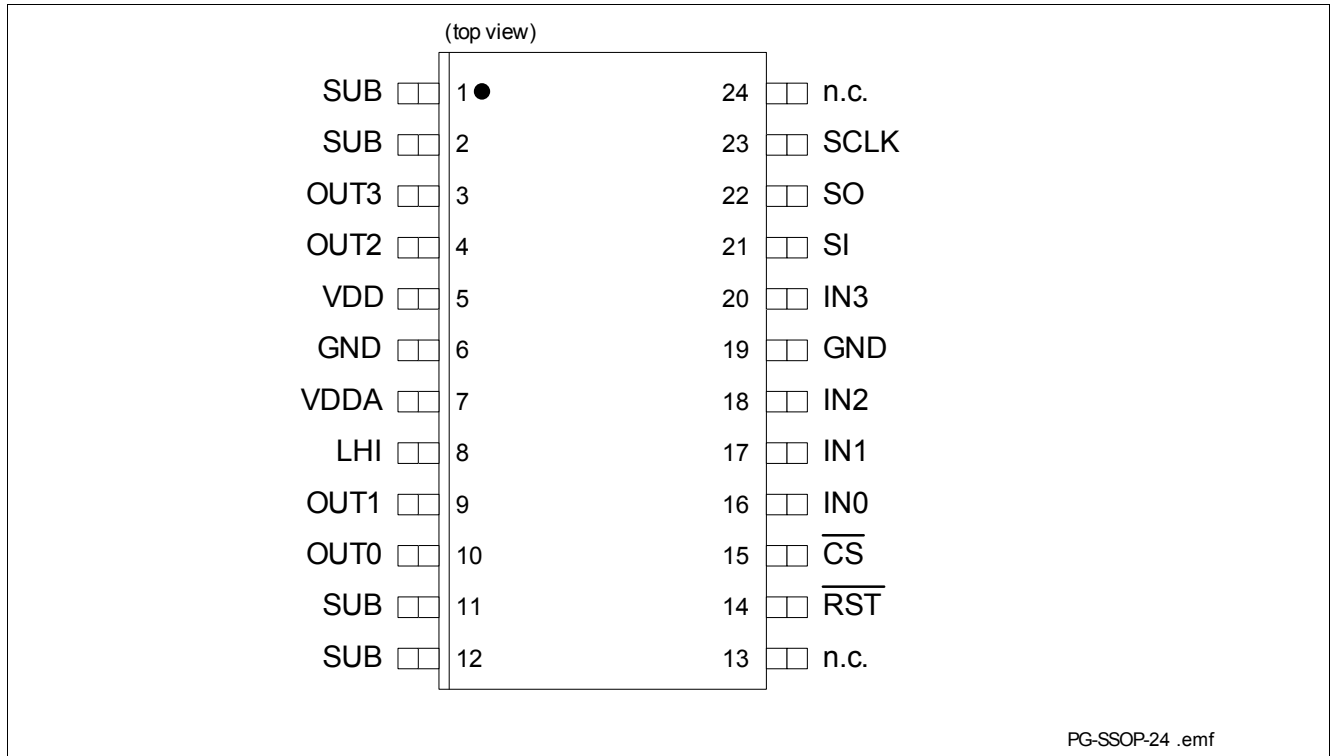

Figure 3 Pin Configuration

#### 3.2 Pin Definitions and Functions

Pin	Symbol	I/O <sup>1)</sup>	Function
<b>Power Supply</b>			
5	$V_{DD}$	-	<b>Digital Supply Voltage;</b> Connected to 5V Voltage with Reverse protection Diode and Filter against EMC
7	$V_{DDA}$	-	<b>Analog Supply Voltage;</b>
6,19	GND	-	<b>Ground;</b> common ground for digital, analog and power
1,2,11,12	SUB	-	<b>Substrate;</b> shorted to die pad, can be left not connected or used for thermal connection and shorted to ground
<b>Power Stages</b>			
10	OUT0	O	<b>Output Channel 0;</b> Drain of power transistor channel 0
9	OUT1	O	<b>Output Channel 1;</b> Drain of power transistor channel 1
4	OUT2	O	<b>Output Channel 2;</b> Drain of power transistor channel 2
3	OUT3	O	<b>Output Channel 3;</b> Drain of power transistor channel 3
<b>Inputs</b>			
16	IN0	I	PD <b>Control Input;</b> Digital input 3.3 V or 5V. In case of not used keep open.
17	IN1	I	PD <b>Control Input;</b> Digital input 3.3 V or 5V. In case of not used keep open.

**Pin Configuration**

Pin	Symbol	I/O <sup>1)</sup>		Function
18	IN2	I	PD	<b>Control Input;</b> Digital input 3.3 V or 5V. In case of not used keep open.
20	IN3	I	PD	<b>Control Input;</b> Digital input 3.3 V logic. In case of not used keep open.
8	LHI	I	PD	<b>Limp Home;</b> Digital input 3.3 V or 5V. In case of not used keep open.
14	$\overline{\text{RST}}$	I	PD	<b>Reset input pin;</b> Digital input 3.3 V or 5V. Low active
<b>SPI</b>				
15	$\overline{\text{CS}}$	I	PU	<b>SPI chip select;</b> Digital input 3.3 V or 5V. Low active
23	SCLK	I	PD	<b>serial clock;</b> Digital input 3.3 V or 5V.
21	SI	I	PD	<b>serial data in;</b> Digital input 3.3 V or 5V.
22	SO	O		<b>serial data out;</b> Digital input 3.3 V or 5V.
<b>Others</b>				
13,24	n.c.	-		<b>not connected;</b> pin not used

1) O: Output, I: Input,  
 PD: pull-down resistor integrated,  
 PU pull-up resistor integrated



## 4 General Product Characteristics

### 4.1 Absolute Maximum Ratings

#### Absolute Maximum Ratings <sup>1)</sup>

$T_j = -40\text{ °C}$  to  $+150\text{ °C}$ ;  $V_{DD} = 3.0\text{ V}$  to  $V_{DDA}$ ,  $V_{DDA} = 4.5\text{ V}$  to  $5.5\text{ V}$ .

All voltages with respect to ground, positive current flowing into pin (unless otherwise specified)

Pos.	Parameter	Symbol	Limit Values		Unit	Conditions
			Min.	Max.		

#### Power Supply

4.1.1	Digital supply voltage	$V_{DD}$	-0.3	5.5	V	–
4.1.2	Analog supply voltage	$V_{DDA}$	-0.3	5.5	V	–

#### Power Stages

4.1.3	Load current	$I_D$	-0.5	0.5	A	–	
4.1.4	Output voltage for short circuit protection (single pulse)	$V_D$	–	36	V	–	
4.1.5	Voltage at power transistor	$V_{DS}$	–	41	V	active clamped	
4.1.6	Maximum energy dissipation one channel	$E_{AS}$			mJ	<sup>2)</sup>	
	single pulse		–	65			$T_{j(0)} = 85\text{ °C}$ $I_{D(0)} = 0.35\text{ A}$
	single pulse		–	30			$T_{j(0)} = 150\text{ °C}$ $I_{D(0)} = 0.25\text{ A}$
	repetitive ( $1 \cdot 10^4$ cycles) repetitive ( $1 \cdot 10^6$ cycles)	$E_{AR}$	–	18			$T_{j(0)} = 150\text{ °C}$ $I_{D(0)} = 0.25\text{ A}$
			–	13		$I_{D(0)} = 0.17\text{ A}$	

#### Logic Pins

4.1.7	Voltage at input pins	$V_{IN0..3}$	-0.3	5.5	V	–
4.1.8	Voltage at LHI pin	$V_{LHI}$	-0.3	5.5	V	–
4.1.9	Voltage at reset pin	$V_{RST}$	-0.3	$V_{DD} + 0.3$	V	<sup>3)</sup>
4.1.10	Voltage at chip select pin	$V_{CS}$	-0.3	$V_{DD} + 0.3$	V	<sup>3)</sup>
4.1.11	Voltage at serial clock pin	$V_{SCLK}$	-0.3	$V_{DD} + 0.3$	V	<sup>3)</sup>
4.1.12	Voltage at serial input pin	$V_{SI}$	-0.3	$V_{DD} + 0.3$	V	<sup>3)</sup>
4.1.13	Voltage at serial output pin	$V_{SO}$	-0.3	$V_{DD} + 0.3$	V	<sup>3)</sup>

#### Temperatures

4.1.14	Junction Temperature during operation	$T_j$	-40	150	°C	–
4.1.15	Storage Temperature	$T_{stg}$	-55	150	°C	–

#### ESD Susceptibility

4.1.16	ESD Resistivity	$V_{ESD}$			kV	HBM <sup>4)</sup>
	Output		-4	4		
	Input / SPI		-2	2		

1) Not subject to production test, specified by design.

2) Pulse shape represents inductive switch off:  $I_D(t) = I_D(0) \times (1 - t / t_{pulse})$ ;  $0 < t < t_{pulse}$

3)  $V_{DD} + 0.3\text{ V} < 5.5\text{ V}$

4) ESD susceptibility, HBM according to EIA/JESD 22-A114B

*Note: Stresses above the ones listed here may cause permanent damage to the device. Exposure to absolute maximum rating conditions for extended periods may affect device reliability.*

*Note: Integrated protection functions are designed to prevent IC destruction under fault conditions described in the data sheet. Fault conditions are considered as "outside" normal operating range. Protection functions are not designed for continuous repetitive operation.*

## 4.2 Functional Range

Pos.	Parameter	Symbol	Limit Values		Unit	Conditions
			Min.	Max.		
4.2.1	Digital supply voltage	$V_{DD}$	3.0	5.5	V	–
4.2.2	Analog supply voltage	$V_{DDA}$	4.5	5.5	V	–
4.2.3	Digital supply current all channels ON	$I_{DD(ON)}$	–	0.5	mA	–
4.2.4	Analog supply current all channels ON	$I_{DDA(ON)}$	–	5	mA	–
4.2.5	Analog supply turn-ON time	$t_{DDA(ON)}$	15	–	µs	$V_{DDA} = 0V$ to 5V (linear)

*Note: Within the functional range the IC operates as described in the circuit description. The electrical characteristics are specified within the conditions given in the related electrical characteristics table.*

## 4.3 Thermal Resistance

*Note: This thermal data was generated in accordance with JEDEC JESD51 standards.*

*For more information, go to [www.jedec.org](http://www.jedec.org).*

Pos.	Parameter	Symbol	Limit Values			Unit	Conditions
			Min.	Typ.	Max.		
4.3.6	Junction to Soldering Point	$R_{thJSP}$	–	–	29	K/W	pin 2,6, 11, 19 <sup>1)</sup>
4.3.7	Junction to Ambient	$R_{thJA}$	–	47	–	K/W	<sup>1)2)</sup>

1) Specified  $R_{thJSP}$  value is simulated at natural convection on a cold plate setup (all pins are fixed to ambient temperature).  $T_a = 25$  °C. LS0 to LS3 are dissipating 1 W power (0.25 W each).

2) Specified  $R_{thJA}$  value is according to Jedec JESD51-2,-7 at natural convection on FR4 2s2p board; The product (Chip+Package PG-SSOP-24) was simulated on a 76.2 x 114.3 x 1.5 mm board with 2 inner copper layers (2 x 70 µm Cu, 2 x 35 µm Cu).  $T_a = 25$  °C, LS1 to LS3 are dissipating 1 W power (0.25 W each).

## 5 Power Supply

The TLE7233G is supplied by two power supply lines  $V_{DD}$  and  $V_{DDA}$ . The digital power supply line  $V_{DD}$  is designed to be functional at a very wide voltage range. The analog power supply  $V_{DDA}$  supports 5 V supply.

Power-on reset functions have been implemented for both supply lines. After start-up of the power supply, all SPI registers are reset to their default values and the device remains in idle mode. Capacitors at pins  $V_{DD}$  - GND and  $V_{DDA}$  - GND are recommended.

A reset pin is available. At low logic level at this pin, all registers are set to their default values and the quiescent supply currents are minimized.

The  $V_{DD}$  supply line is used for the I/O buffer circuits of the SPI pins, therefore the voltage on the SO pin is always related to this supply voltage. A capacitor between pins  $V_{DD}$  and GND is recommended (especially in case of EMI).

To enable the Daisy chain functionality it is necessary to have  $V_{DD}$  and  $V_{DDA}$  in the specified functional range.

The device provides a sleep mode to minimize current consumption, which also resets the register banks. It is controlled by a low active reset pin (RST) which disables the device and minimize the current consumption. The table below gives an overview of the different power modes.

**Table 2 Power modes<sup>1)</sup>**

Power mode	State Description	RESET (low active)	$V_{DD}$	$V_{DDA}$	SCLK	LHI
<b>SLEEP</b>	Device at minimum current consumption	low	X	X	0 Hz	low
<b>IDLE</b>	Device operational, all channels OFF no diagnosis activated	high	ON	ON	0 Hz	low
<b>LIMP HOME</b>	Device in Limp home mode	X	X	ON	X	high
<b>ON</b>	Device operational with enabled channels and diagnostic currents active	high	ON	ON	5 MHz (max)	low

- 1) low: pin input is digital low,  
high: pin input is digital high,  
X: pin state don't care,  
ON: voltage on this analog supply pin is in the specified functional range

## 5.1 Limp Home Mode

The TLE7233G offers the capability of driving dedicated channels during eventual fail-safe operation of the system. This limp home mode is activated by a high signal at pin LHI. In this mode, the SPI registers are reset and the input pins are directly routed to their corresponding channels, see [Table 3](#) for details.

Furthermore, the SPI is ignored and all input pin are referred to  $V_{DDA}$  in order to ensure a defined operation mode if the digital supply or the microcontroller fail.

A high signal on LHI overrides a Reset signal on RST. In case of a limp home during sleep the device will therefore wake up and enter the limp home mode.

During Limp home mode any SPI transmission will receive a TER flag.

After limp home operation all registers are reset and the device enters in sleep mode following low logic RST state, or returns to ON state (all channels OFF with diagnostic currents active). Next SPI transmission will receive a TER Flag.

Input	controlled Output
IN0	OUT0
IN1	OUT1
IN2	OUT2
IN3	OUT3

**Table 3** Routing during limp home mode

## 6 Power Stages

The TLE7233G is a four channel low-side relay switch.

The power stages are made of N-channel vertical power MOSFET transistors.

### 6.1 Input Circuit

The TLE7233G has four input pins, that can be configured to be used for control of the output stages. The  $IN_n$  parameter of the SPI provide the following operation modes:

- channel is in off mode without diagnosis  
(if all channels are programmed to this mode, the device goes into idle mode)
- channel is switched according to signal level at input pin  $IN_x$
- channel is switched on
- channel is switched off with active diagnosis

**Figure 5** shows the input circuit of TLE7233G.

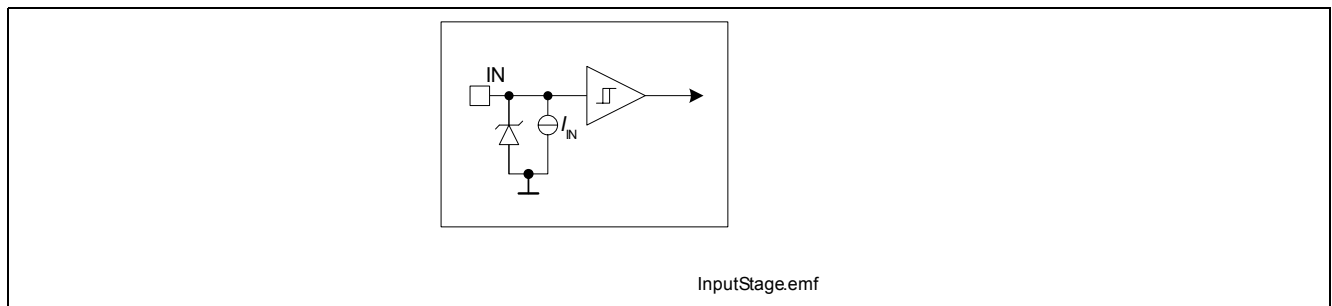

**Figure 4** Input signal conditioning circuit on all input and limp home pins

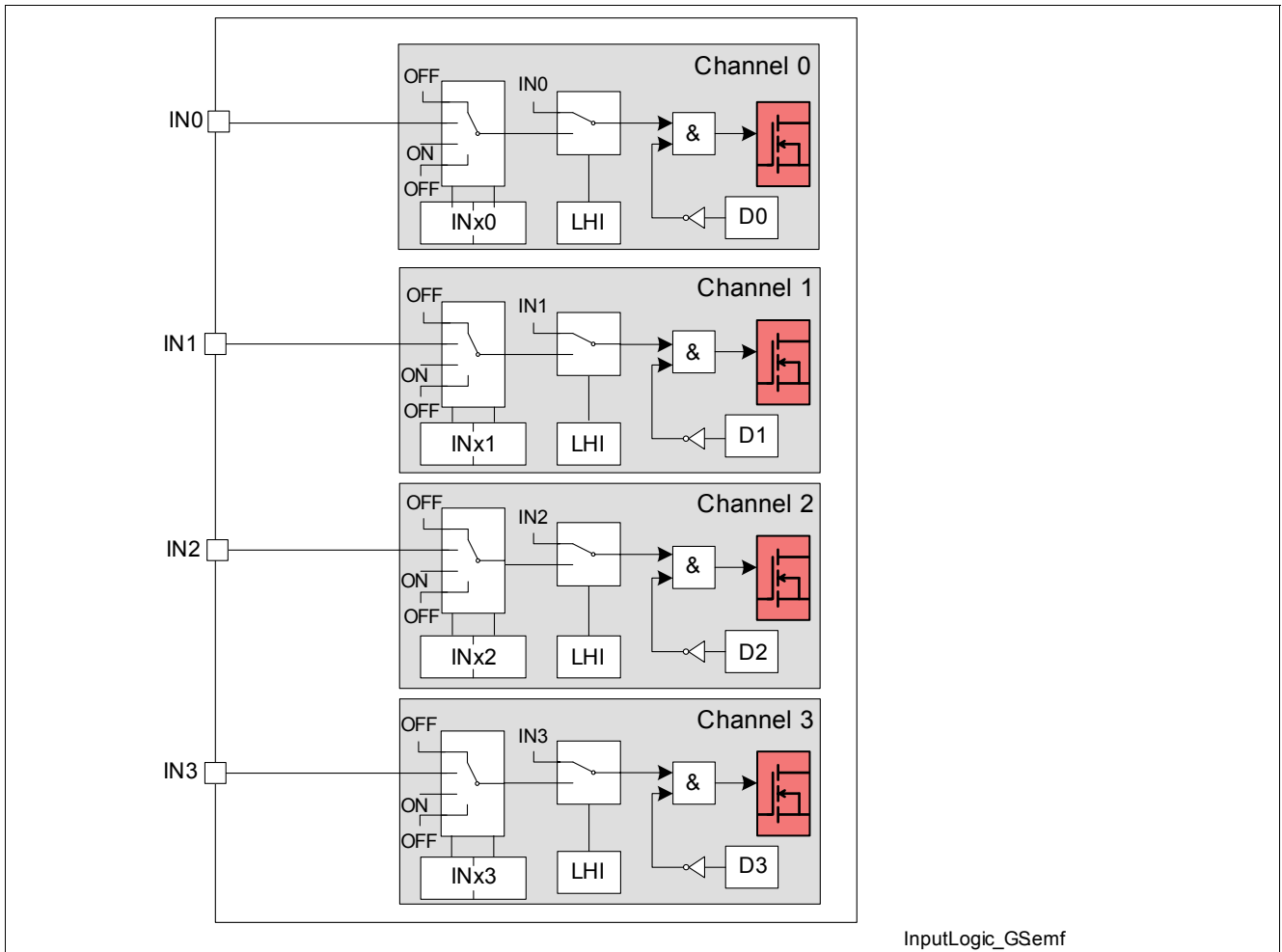
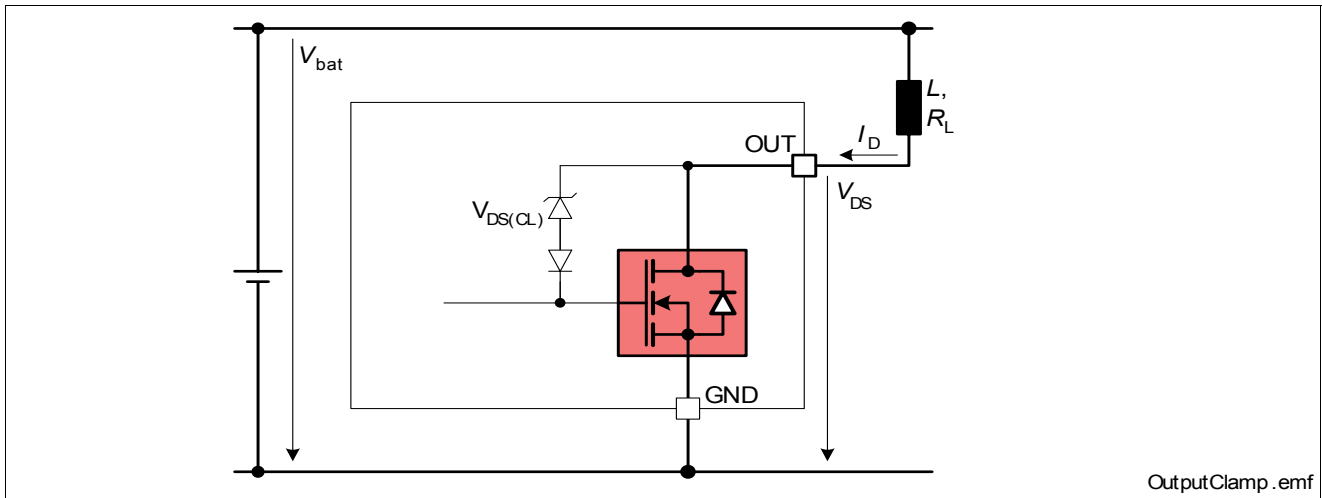

**Figure 5 Input Multiplexer**

The current sink to ground ensures that the channels switch off in case of open input pin. The zener diode protects the input circuit against ESD pulses. After power-on reset, the device enters idle mode.

## 6.2 Inductive Output Clamp

When switching off inductive loads, the potential at pin OUT rises to  $V_{DS(CL)}$  potential, because the inductance intends to continue driving the current. The voltage clamping is necessary to prevent destruction of the device, see [Figure 6](#) for details. Nevertheless, the maximum allowed load inductance is limited.



OutputClamp.emf

Figure 6 Output Clamp Implementation

### Maximum Load Inductance

During demagnetization of inductive loads, energy has to be dissipated in the TLE7233G.

This energy can be calculated with following equation:

$$E = V_{DS(CL)} \cdot \left[ \frac{V_{bat} - V_{DS(CL)}}{R_L} \cdot \ln \left( 1 - \frac{R_L \cdot I_L}{V_{bat} - V_{DS(CL)}} \right) + I_L \right] \cdot \frac{L}{R_L}$$

Following equation simplifies under the assumption of  $R_L = 0$ :

$$E = \frac{1}{2} L I_L^2 \cdot \left( 1 - \frac{V_{bat}}{V_{bat} - V_{DS(CL)}} \right)$$

The maximum energy, which is converted into heat, is limited by the thermal design of the component.

### 6.3 Timing Diagrams

The power transistors are switched on and off with a dedicated slope via the  $\text{IN}$  bits of the serial peripheral interface SPI. The switching times  $t_{ON}$  and  $t_{OFF}$  are designed equally.

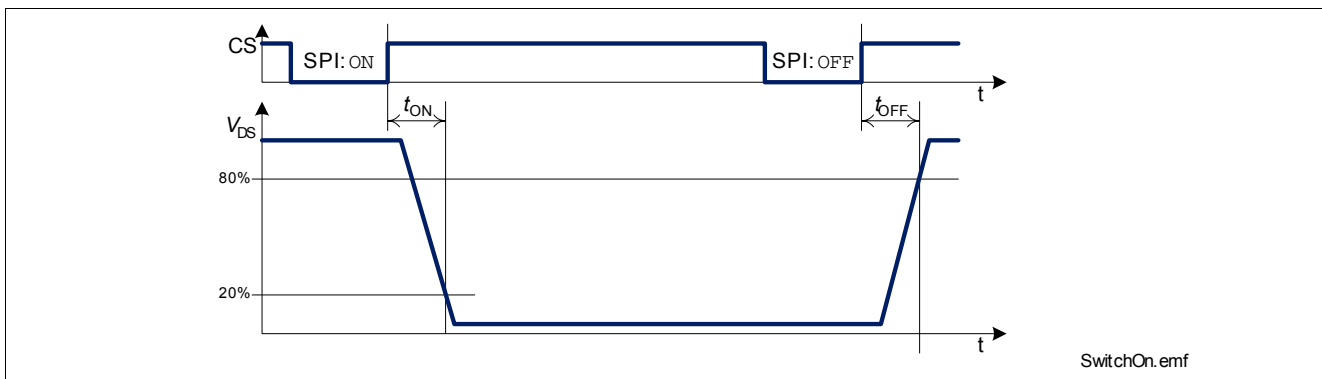

SwitchOn.emf

Figure 7 Switching a Resistive Load

In input mode, a high signal at the input pin is equivalent to a SPI ON command and a low signal to SPI OFF command respectively. Please refer to [Section 9.3](#) for details on operation modes.

The listed switching times are not valid, when switching to or from stand-by mode.

## 6.4 Electrical Characteristics Power Stages

$V_{DD} = 3.0\text{ V}$  to  $V_{DDA}$ ,  $V_{DDA} = 4.5\text{ V}$  to  $5.5\text{ V}$ ,  $T_j = -40\text{ °C}$  to  $+150\text{ °C}$

All voltages with respect to ground, positive current flowing into pin (unless otherwise specified)

typical values:  $V_{DD} = 5.0\text{ V}$ ,  $V_{DDA} = 5.0\text{ V}$ ,  $T_j = 25\text{ °C}$

Pos.	Parameter	Symbol	Limit Values			Unit	Conditions
			Min.	Typ.	Max.		
<b>Power Supply</b>							
6.4.1	Digital supply voltage	$V_{DD}$	3.0	–	5.5	V	–
6.4.2	Digital supply current all channels ON	$I_{DD(ON)}$	–	–	0.5	mA	$V_{DD} = V_{DDA} = 5\text{ V}$ $V_{RST} = V_{CS} = V_{DD}$ $V_{SCLK} = 0\text{ V}$ $V_{IN} = 0\text{ V}$
6.4.3	Digital supply idle current	$I_{DD(idle)}$	–	–	20 20 40	μA	$f_{SCLK} = 0\text{ Hz}$ $V_{RST} = V_{CS} = \text{high}$ $T_j = 25\text{ °C}^{1)}$ $T_j = 85\text{ °C}^{1)}$ $T_j = 150\text{ °C}$
6.4.4	Digital supply sleep current	$I_{DD(sleep)}$	–	–	5 5 20	μA	$V_{RST} = 0\text{ V}$ $T_j = 25\text{ °C}^{1)}$ $T_j = 85\text{ °C}^{1)}$ $T_j = 150\text{ °C}$
6.4.5	Digital power-on reset threshold voltage	$V_{DD(PO)}$	–	–	3.0	V	–
6.4.6	Analog supply voltage	$V_{DDA}$	4.5	–	5.5	V	–
6.4.7	Analog supply current all channels ON	$I_{DDA(ON)}$	–	–	5	mA	–
6.4.8	Analog supply idle current	$I_{DDA(idle)}$	–	–	25	μA	$V_{CS} = V_{DD}$ $V_{SI} = 0\text{ V}$ $V_{SCLK} = 0\text{ V}$ $T_j = 25\text{ °C}^{1)}$ $T_j = 85\text{ °C}^{1)}$ $T_j = 150\text{ °C}$
6.4.9	Analog supply sleep current	$I_{dd(sleep)}$	–	–	5 5 20	μA	$V_{CS} = V_{DD}$ $V_{RST} = 0\text{ V}$ $T_j = 25\text{ °C}^{1)}$ $T_j = 85\text{ °C}^{1)}$ $T_j = 150\text{ °C}$
6.4.10	Analog power-on reset threshold voltage	$V_{DDA(PO)}$	–	–	4.5	V	–
<b>Output Characteristics</b>							
6.4.11	On-State resistance per channel	$R_{DS(ON)}$	–	1.0 2.0	2.2	Ω	$I_L = 250\text{ mA}$ $T_j = 25\text{ °C}^{1)}$ $T_j = 150\text{ °C}$
6.4.12	Nominal load current	$I_{D(nom)}$	390	415	–	mA	<sup>2)</sup>



$V_{DD} = 3.0 \text{ V to } V_{DDA}, V_{DDA} = 4.5\text{V to } 5.5\text{V}, T_j = -40 \text{ }^\circ\text{C to } +150 \text{ }^\circ\text{C}$ 

All voltages with respect to ground, positive current flowing into pin (unless otherwise specified)

 typical values:  $V_{DD} = 5.0 \text{ V}, V_{DDA} = 5.0 \text{ V}, T_j = 25 \text{ }^\circ\text{C}$ 

Pos.	Parameter	Symbol	Limit Values			Unit	Conditions
			Min.	Typ.	Max.		
6.4.13	Output leakage current (per channel)	$I_{D(OFF)}$	–	–	1 2 5	$\mu\text{A}$	$V_{DS} = 13.5 \text{ V}$ $T_j = 25 \text{ }^\circ\text{C}^1)$ $T_j = 85 \text{ }^\circ\text{C}^1)$ $T_j = 150 \text{ }^\circ\text{C}$
6.4.14	Output clamping voltage	$V_{DS(CL)}$	41	–	52	V	<sup>3)</sup>

**Input Pin Characteristics**

6.4.15	L level of pin IN & LHI	$V_{IN(L)}$	0	–	0.9	V	–
6.4.16	H level of pin IN & LHI	$V_{IN(H)}$	2.2	–	5.5	V	–
6.4.17	L-input pull-down current through pin	$I_{IN(L)}$	3	12	80	$\mu\text{A}$	$V_{DD} = 5 \text{ V}^1)$ $V_{IN} = 0.6 \text{ V}$
6.4.18	H-input pull-down current through pin	$I_{IN(H)}$	10	40	80	$\mu\text{A}$	$V_{DD} = 5 \text{ V}$ $V_{IN} = 5 \text{ V}$
6.4.19	L level of pin RST	$V_{RST(L)}$	0	–	0.2* $V_{DD}$		–
6.4.20	H level of pin RST	$V_{RST(H)}$	0.4* $V_{DD}$	–	$V_{DD}$		–
6.4.21	L-input pull-down current through pin RST	$I_{RST(L)}$	3	12	80	$\mu\text{A}$	$V_{DD} = 5 \text{ V}^1)$ $V_{RST} = 0.6 \text{ V}$
6.4.22	H-input pull-down current through pin RST	$I_{RST(H)}$	10	40	80	$\mu\text{A}$	$V_{DD} = 5 \text{ V}$ $V_{RST} = 5 \text{ V}$

**Timings**

6.4.23	Sleep wake-up time	$t_{wu(sleep)}$	–	–	200	$\mu\text{s}$	–
6.4.24	Reset duration	$t_{RST(L)}$	1	–	–	$\mu\text{s}$	–
6.4.25	Turn-on time $V_{DS} = 20\% V_{bat}$	$t_{ON}$	–	–	60	$\mu\text{s}$	$V_{bb} = 13.5 \text{ V}$ $I_{DS} = 250 \text{ mA}$ , resistive load
6.4.26	Turn-off time $V_{DS} = 80\% V_{bb}$	$t_{OFF}$	–	–	60	$\mu\text{s}$	$V_{bb} = 13.5 \text{ V}$ $I_{DS} = 250 \text{ mA}$ , resistive load

1) Not subject to production test, specified by design

2) calculated value based on following parameters:

 all channels on with equal load current,  $R_{DS(ON)} = R_{DS(ON,150^\circ\text{C})}$ ,  $T_a = 85 \text{ }^\circ\text{C}$ ,  $T_{j,max} = 150 \text{ }^\circ\text{C}$ ,  $R_{th} = R_{thJA(typ)}$ 

3) maximum value is increasing in sleep mode

## 7 Protection Functions

Note: The device provides embedded protective functions. Integrated protection functions are designed to prevent IC destruction under fault conditions described in this datasheet. Fault conditions are considered as "outside" normal operating range. Protection functions are not designed for continuous repetitive operation.

### 7.1 Over Load Protection

The TLE7233G is protected against over load or short circuit of the load. After time  $t_{\text{OFF(OVL)}}$ , the over loaded channel  $n$  switches off and therefore the corresponding diagnostics flag  $D_n$  is set. The channel can be switched on after clearing the diagnostics flag. Please refer to [Figure 8](#) for details.

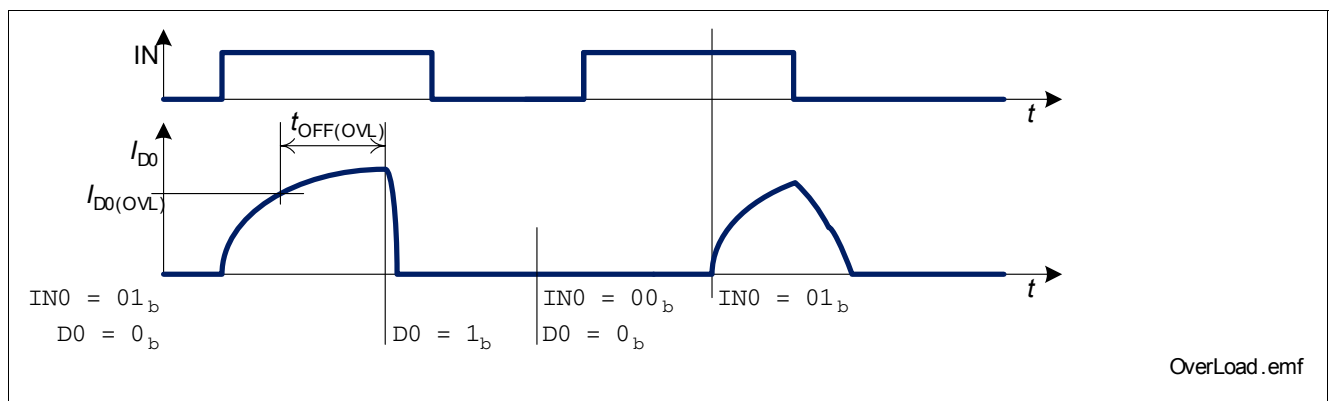

Figure 8 Shut Down at Over Load

### 7.2 Over Temperature Protection

A temperature sensor for each channel causes an overheated channel  $n$  to switch off to prevent destruction. Then the according diagnostics flag  $D_n$  is set. The channel can be switched on after clearing the diagnosis flag. Please refer to [Section 8](#) for information on diagnostics features.

### 7.3 Reverse Polarity Protection

In case of reverse polarity, the intrinsic body diode of the power transistor causes increased power dissipation. The reverse current through the intrinsic body diode of the power transistor has to be limited by the connected load. The  $V_{DD}$  and  $V_{DDA}$  supply pins must be externally protected against reverse polarity. The over temperature and over load protection are not active during reverse polarity.

## 7.4 Electrical Characteristics Protection

$V_{DD} = 3.0\text{ V}$  to  $V_{DDA}$ ,  $V_{DDA} = 4.5\text{ V}$  to  $5.5\text{ V}$ ,  $T_j = -40\text{ °C}$  to  $+150\text{ °C}$

All voltages with respect to ground, positive current flowing into pin (unless otherwise specified)

typical values:  $V_{DD} = 5.0\text{ V}$ ,  $V_{DDA} = 5.0\text{ V}$ ,  $T_j = 25\text{ °C}$

Pos.	Parameter	Symbol	Limit Values			Unit	Conditions
			Min.	Typ.	Max.		
<b>Over Load Protection</b>							
7.4.1	Over load detection current	$I_{D(OVL)}$	0.5	–	0.95	A	–
7.4.2	Over load shut-down delay time	$t_{OFF(OVL)}$	5	–	60	μs	–
<b>Over Temperature Protection</b>							
7.4.3	Thermal shut down temperature	$T_{j(SC)}$	150	170 <sup>1)</sup>	–	°C	–
7.4.4	Thermal hysteresis	$\Delta T_j$	–	10	–	K	<sup>1)</sup>

1) Not subject to production test, specified by design

## 8 Diagnostic Features

The SPI of TLE7233G provides diagnosis information about the device and about the load. The diagnosis information of the protective functions of channel  $n$  is latched in the diagnosis flag  $D_n$ . The open load diagnosis of channel  $n$  is latched in the diagnosis flag  $OL_n$ . Both flags are cleared by  $IN_n = 00_B$  and the diagnosis current  $I_{D(PD)}$ , which is a small pull down current, is disabled.

Following table shows possible failure modes and the according protective and diagnostic action.

Failure Mode	Comment
Open Load or short circuit to GND	<p><b>Diagnosis, when channel <math>n</math> is switched on:</b>  <math>IN_n = 01_B</math>: if input pin is high: none  <math>IN_n = 10_B</math>: none</p> <p><b>Diagnosis, when channel <math>n</math> is switched off:</b>  <math>IN_n = 00_B</math>: none, diagnosis flags are cleared and the diagnosis current is switched off  <math>IN_n = 01_B</math>: if input pin is low, according to voltage at the output pin, the flag <math>OL_n</math> is set after time <math>t_{d(OL)}</math>  <math>IN_n = 11_B</math>: according to voltage level at the output pin, flags <math>OL_n</math> are set after time <math>t_{d(OL)}</math></p>
Over temperature	<p>When over temperature occurs, the affected channel <math>n</math> is switched off. The according diagnosis flag <math>D_n</math> is set.            The diagnosis flags are latched until they have been cleared by <math>IN_n = 00_B</math>. The over temperature detection is active in ON-state as well as OFF-state.</p>
Over Load (Short Circuit)	<p>When over load is detected at channel <math>n</math>, the affected channel is switched off after time <math>t_{OFF(OVL)}</math> and the dedicated diagnosis flag <math>D_n</math> is set.            The diagnosis flags are latched until they have been cleared by <math>IN_n = 00_B</math>.</p>

### 8.1 Open Load Diagnosis timing

The TLE7233G offers a open load diagnosis for each channel in OFF mode.

The time  $t_{d(fault)}$  is applied to filter short time events.

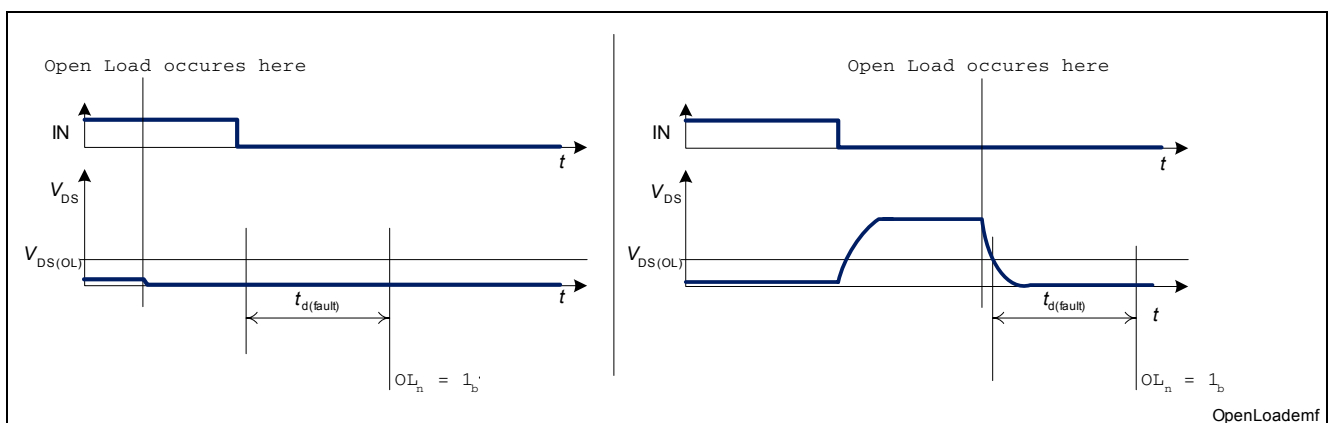

Figure 9 Open Load timing

## 8.2 Electrical Characteristics Diagnostic

$V_{DD} = 3.0\text{ V}$  to  $V_{DDA}$ ,  $V_{DDA} = 4.5\text{ V}$  to  $5.5\text{ V}$ ,  $T_j = -40\text{ °C}$  to  $+150\text{ °C}$

All voltages with respect to ground, positive current flowing into pin (unless otherwise specified)

typical values:  $V_{DD} = 5.0\text{ V}$ ,  $V_{DDA} = 5.0\text{ V}$ ,  $T_j = 25\text{ °C}$

Pos.	Parameter	Symbol	Limit Values			Unit	Conditions
			Min.	Typ.	Max.		
<b>OFF State Diagnosis</b>							
8.2.1	Open load detection threshold voltage	$V_{DS(OL)}$	1.0	–	2.5	V	–
8.2.2	Output pull-down diagnosis current per channel	$I_{D(PD)}$	–	–	100	$\mu\text{A}$	$V_{DS} = 13.5\text{ V}$
8.2.3	Open load diagnosis delay time	$t_{d(OL)}$	30	–	200	$\mu\text{s}$	–
<b>ON State Diagnosis</b>							
8.2.4	Over load detection current	$I_{D(OVL)}$	0.5	–	0.95	A	–
8.2.5	Over load detection delay time	$t_{OFF(OVL)}$	5	–	60	$\mu\text{s}$	–

## 9 Serial Peripheral Interface (SPI)

The diagnosis and control interface is based on a serial peripheral interface (SPI).

The SPI is a full duplex synchronous serial slave interface, which uses four lines: SO, SI, SCLK and  $\overline{\text{CS}}$ . Data is transferred by the lines SI and SO at the data rate given by SCLK. The falling edge of  $\overline{\text{CS}}$  indicates the beginning of a data access. Data is sampled in on line SI at the falling edge of SCLK and shifted out on line SO at the rising edge of SCLK. Each access must be terminated by a rising edge of  $\overline{\text{CS}}$ . A modulo 8 counter ensures that data is taken only, when a multiple of 8 bit has been transferred. The interface provides daisy chain capability.

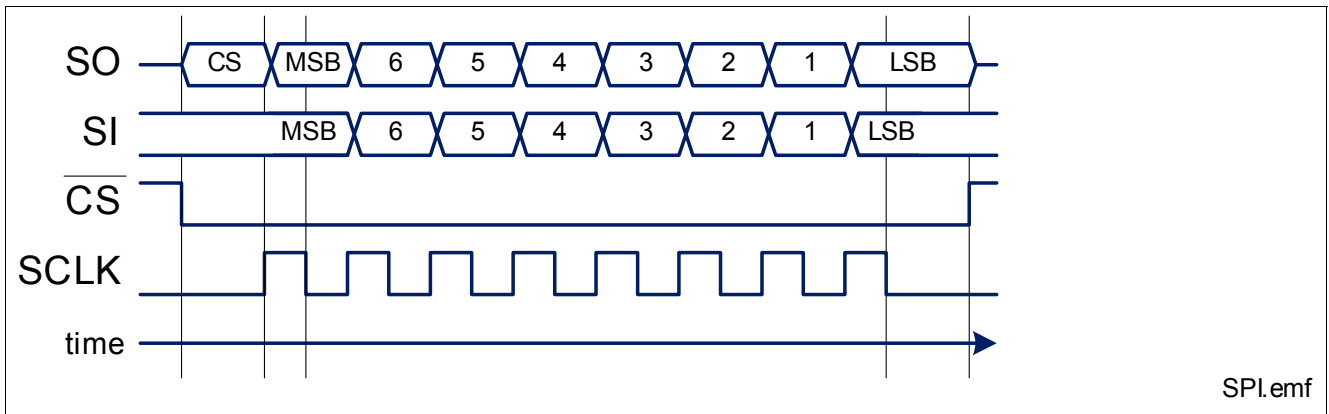

**Figure 10** Serial Peripheral Interface

The SPI protocol is described in [Section 9.3](#). It is reset to the default values after power-on reset.

### 9.1 SPI Signal Description

#### $\overline{\text{CS}}$ - Chip Select:

The system micro controller selects the TLE7233G by means of the  $\overline{\text{CS}}$  pin. Whenever the pin is in low state, data transfer can take place. When  $\overline{\text{CS}}$  is in high state, any signals at the SCLK and SI pins are ignored and SO is forced into a high impedance state.

#### $\overline{\text{CS}}$ High to Low transition:

- The diagnosis information is transferred into the shift register.
- SO changes from high impedance state to high or low state depending on the logic OR combination between the transmission error flag ( $\text{TER}$ ) and the signal level at pin SI. As a result, even in daisy chain configuration, a high signal indicates a faulty transmission. The transmission error flag is set after any kind of reset, so a reset between two SPI commands is indicated. For details, please refer to [Figure 11](#). This information stays available to the first rising edge of SCLK.

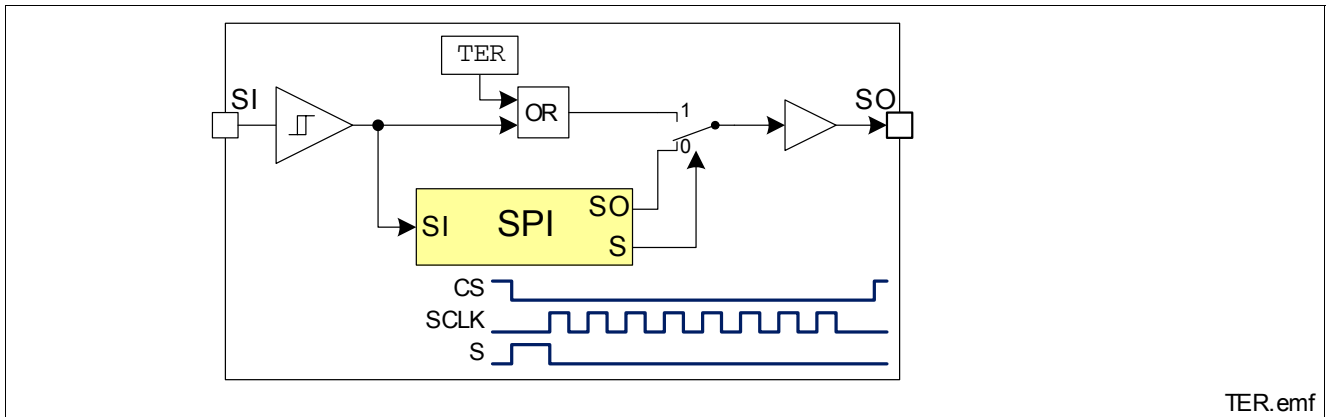

TER.emf

Figure 11 Transmission Error Flag on SO Line

### $\overline{CS}$ Low to High transition:

Data from shift register is transferred into the input matrix register only, when after the falling edge of  $\overline{CS}$  exactly a multiple (1, 2, 3, ...) of eight SCLK signals have been detected.

### SCLK - Serial Clock:

This input pin clocks the internal shift register. The serial input (SI) transfers data into the shift register on the falling edge of SCLK while the serial output (SO) shifts diagnostic information out on the rising edge of the serial clock. It is essential that the SCLK pin is in low state whenever chip select  $\overline{CS}$  makes any transition.

### SI - Serial Input:

Serial input data bits are shifted in at this pin, the most significant bit first. SI information is read on the falling edge of SCLK. Please refer to [Section 9.3](#) for further information.

### SO - Serial Output:

Data is shifted out serially at this pin, the most significant bit first. SO is in high impedance state until the  $\overline{CS}$  pin goes to low state. New data will appear at the SO pin following the rising edge of SCLK. Please refer to [Section 9.3](#) for further information.

## 9.2 Daisy Chain Capability

The SPI of TLE7233G provides daisy chain capability. In this configuration several devices are activated by the same  $\overline{CS}$  signal  $\overline{MCS}$ . The SI line of one device is connected with the SO line of another device (see [Figure 12](#)), which builds a chain. The ends of the chain are connected with the output and input of the master device, MO and MI respectively. The master device provides the master clock MCLK, which is connected to the SCLK line of each device in the chain.

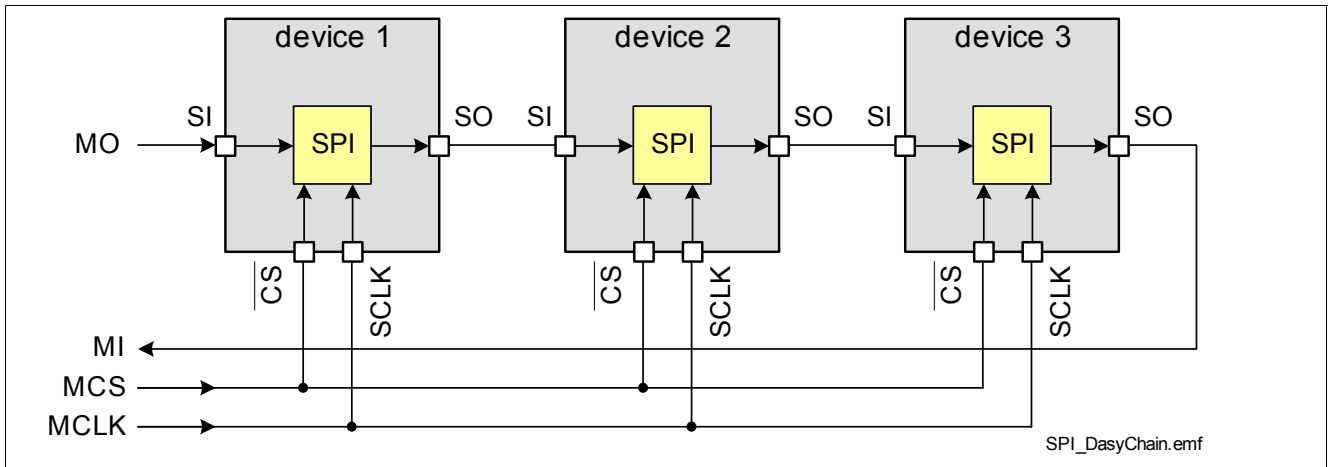

Figure 12 Daisy Chain Configuration

In the SPI block of each device, there is one shift register where one bit from SI line is shifted in each SCLK. The bit shifted out can be seen at SO. After 8 SCLK cycles, the data transfer for one device has been finished. In single chip configuration, the  $\overline{CS}$  line must transit from low to high to make the device accept the transferred data. In daisy chain configuration the data shifted out at device #1 has been shifted in to device #2. When using three devices in daisy chain, three times 8 bits have to be shifted through the devices. After that, the  $\overline{MCS}$  line must transit from low to high (see Figure 13).

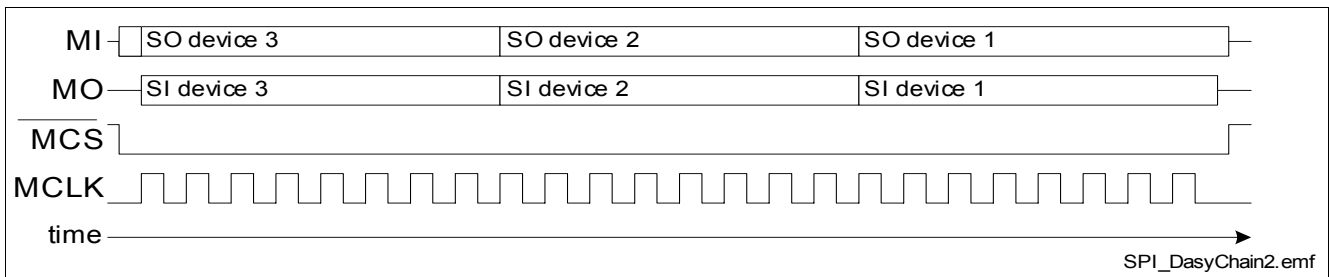
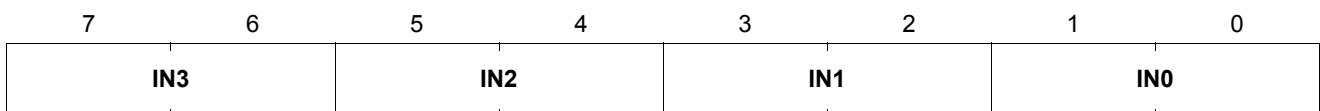

Figure 13 Data Transfer in Daisy Chain Configuration

### 9.3 SPI Protocol

The SPI protocol of the TLE7233G provides two registers. The input register and the diagnosis register. The diagnosis register contains four pairs of diagnosis flags, the input register contains the input multiplexer configuration. After power-on reset, all register bits are cleared to 0.

#### SI





Field	Bits	Type	Description
INn (n = 3-0)	7:6, 5:4, 3:2, 1:0	W	<p><b>Input Register Channel n</b></p> <p><b>00<sub>B</sub></b> Stand-by Mode: Fast channel switched off. Diagnosis flags are cleared. Diagnosis current is disabled.</p> <p><b>01<sub>B</sub></b> Input Direct drive mode: Channel is switched according to signal at corresponding input pin. Diagnosis current is enabled in OFF-state. See <a href="#">Figure 5</a> for details.</p> <p><b>10<sub>B</sub></b> ON Mode: Channel is switched on. Diagnosis current is enabled.</p> <p><b>11<sub>B</sub></b> OFF Mode: Channel is switched off. Diagnosis current is enabled.</p>

SO

Reset Value: 100<sub>H</sub>

CS <sup>1)</sup>	7	6	5	4	3	2	1	0
TER	OL3	D3	OL2	D2	OL1	D1	OL0	D0

1) This bit is valid between  $\overline{CS}$  hi -> lo and first SCLK lo -> hi transition.

Field	Bits	Type	Description
TER	CS	R	<b>Transmission Error</b> 0 Previous transmission was successful (modulo 8 clocks received). 1 Previous transmission failed or first transmission after reset.
OLn (n = 3-0)	7, 5, 3, 1	R	<b>Open Load Flag of channel n</b> 0 Normal operation. 1 Open load has occurred in OFF state.
Dn (n = 3-0)	6, 4, 2, 0	R	<b>Diagnosis Flag of channel n</b> 0 Normal operation. 1 Over load or over temperature switch off has occurred in ON state.

## 9.4 Timing Diagrams

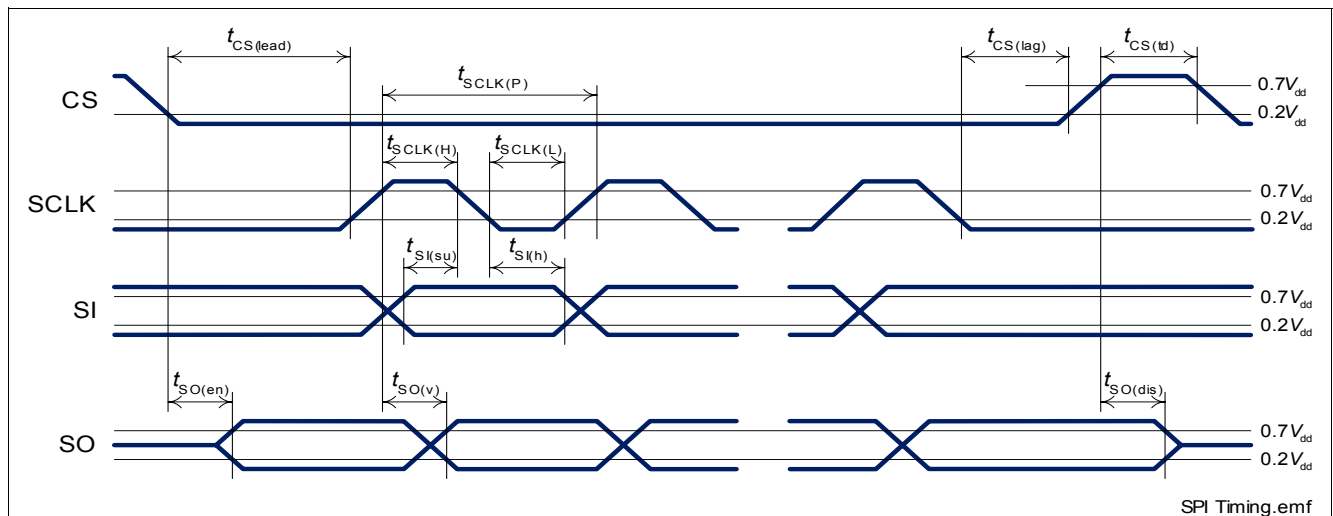

Figure 14 Timing Diagram

## 9.5 Electrical Characteristics SPI

$V_{DD} = 3.0\text{ V}$  to  $V_{DDA}$ ,  $V_{DDA} = 4.5\text{ V}$  to  $5.5\text{ V}$ ,  $T_j = -40\text{ }^\circ\text{C}$  to  $+150\text{ }^\circ\text{C}$

All voltages with respect to ground, positive current flowing into pin (unless otherwise specified)

typical values:  $V_{DD} = 5.0\text{ V}$ ,  $V_{DDA} = 5.0\text{ V}$ ,  $T_j = 25\text{ }^\circ\text{C}$

Pos.	Parameter	Symbol	Limit Values			Unit	Conditions
			Min.	Typ.	Max.		
<b>Input Characteristics (CS, SCLK, SI)</b>							
9.5.1	L level of pin $\overline{\text{CS}}$ SCLK SI	$V_{\text{CS(L)}}$ $V_{\text{SCLK(L)}}$ $V_{\text{SI(L)}}$	0	–	0.2* $V_{\text{DD}}$		–
9.5.2	H level of pin $\overline{\text{CS}}$ SCLK SI	$V_{\text{CS(H)}}$ $V_{\text{SCLK(H)}}$ $V_{\text{SI(H)}}$	0.5* $V_{\text{DD}}$	–	$V_{\text{DD}}$		–
9.5.3	L-input pull-up current through $\overline{\text{CS}}$	$I_{\text{CS(L)}}$	5	17	40	$\mu\text{A}$	$V_{\text{CS}} = 0\text{ V}$
9.5.4	H-input pull-up current through $\overline{\text{CS}}$	$I_{\text{CS(H)}}$	3	15	40	$\mu\text{A}$	<sup>1)</sup> $V_{\text{CS}} = 2\text{ V}$
9.5.5	L-input pull-down current through pin SCLK SI	$I_{\text{SCLK(L)}}$ $I_{\text{SI(L)}}$	3	12	80	$\mu\text{A}$	<sup>1)</sup> $V_{\text{SCLK}} = 0.6\text{ V}$ $V_{\text{SI}} = 0.6\text{ V}$
9.5.6	H-input pull-down current through pin SCLK SI	$I_{\text{SCLK(H)}}$ $I_{\text{SI(H)}}$	10	40	80	$\mu\text{A}$	$V_{\text{SCLK}} = 5\text{ V}$ $V_{\text{SI}} = 5\text{ V}$
<b>Output Characteristics (SO)</b>							
9.5.7	L level output voltage	$V_{\text{SO(L)}}$	0	–	0.4	V	$I_{\text{SO}} = -2\text{ mA}$
9.5.8	H level output voltage	$V_{\text{SO(H)}}$	$V_{\text{DD}} - 0.5\text{ V}$	–	$V_{\text{DD}}$		$I_{\text{SO}} = 1.5\text{ mA}$
9.5.9	Output tristate leakage current	$I_{\text{SO(OFF)}}$	-10	–	10	$\mu\text{A}$	$V_{\text{CS}} = V_{\text{DD}}$
<b>Timings</b>							
9.5.10	Serial clock frequency	$f_{\text{SCLK}}$	0	–	5	MHz	–
9.5.11	Serial clock period	$t_{\text{SCLK(P)}}$	200	–	–	ns	–
9.5.12	Serial clock high time	$t_{\text{SCLK(H)}}$	50	–	–	ns	–
9.5.13	Serial clock low time	$t_{\text{SCLK(L)}}$	50	–	–	ns	–
9.5.14	Enable lead time (falling $\overline{\text{CS}}$ to rising SCLK)	$t_{\text{CS(lead)}}$	250	–	–	ns	–
9.5.15	Enable lag time (falling SCLK to rising $\overline{\text{CS}}$ )	$t_{\text{CS(lag)}}$	250	–	–	ns	–
9.5.16	Transfer delay time (rising $\overline{\text{CS}}$ to falling $\overline{\text{CS}}$ )	$t_{\text{CS(td)}}$	250	–	–	ns	–
9.5.17	Data setup time (required time SI to falling SCLK)	$t_{\text{SI(su)}}$	20	–	–	ns	–
9.5.18	Data hold time (falling SCLK to SI)	$t_{\text{SI(h)}}$	20	–	–	ns	–

$V_{DD} = 3.0\text{ V}$  to  $V_{DDA}$ ,  $V_{DDA} = 4.5\text{V}$  to  $5.5\text{V}$ ,  $T_j = -40\text{ }^\circ\text{C}$  to  $+150\text{ }^\circ\text{C}$

All voltages with respect to ground, positive current flowing into pin (unless otherwise specified)

typical values:  $V_{DD} = 5.0\text{ V}$ ,  $V_{DDA} = 5.0\text{ V}$ ,  $T_j = 25\text{ }^\circ\text{C}$

Pos.	Parameter	Symbol	Limit Values			Unit	Conditions
			Min.	Typ.	Max.		
9.5.19	Output enable time (falling $\overline{\text{CS}}$ to SO valid)	$t_{\text{SO(en)}}$	–	–	200	ns	$C_L = 50\text{ pF}$ <sup>1)</sup>
9.5.20	Output disable time (rising $\overline{\text{CS}}$ to SO tri-state)	$t_{\text{SO(dis)}}$	–	–	200	ns	$C_L = 50\text{ pF}$ <sup>1)</sup>
9.5.21	Output data valid time with capacitive load	$t_{\text{SO(v)}}$	–	–	100	ns	$C_L = 50\text{ pF}$ <sup>1)</sup>

1) Not subject to production test, specified by design.

## 10 Application Information

Note: The following information is given as a hint for the implementation of the device only and shall not be regarded as a description or warranty of a certain functionality, condition or quality of the device.

Figure 15 shows a simplified application circuit.  $V_{DDA}$  and  $V_{DD}$  need to be reverse protected. Also the Resistors in the digital pins are for reverse polarity protection.

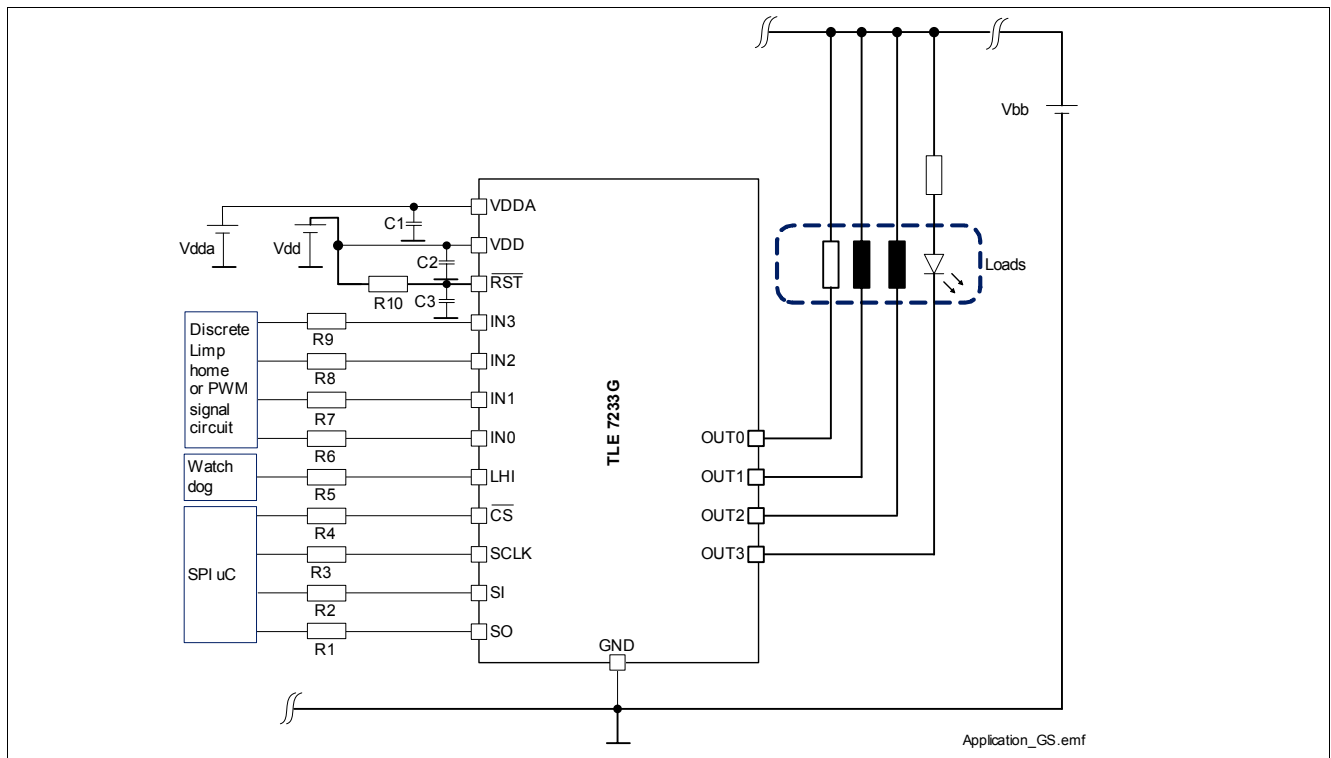

Figure 15 Application Diagram

Note: This is a very simplified example of an application circuit. The function must be verified in the real application. C1,C2,C3 are recommended to be 4.7nF and all Resistors can be 1kOhm.

For further information you may contact <http://www.infineon.com/>



## 12 Revision History

Version	Date	Changes
Rev. 1.1	2011-04-12	new parameter 4.2.5 on page 10 "Analog supply turn-ON time" added
Rev. 1.0	2008-02-28	initial released Datasheet

**Edition 2011-04-12**

**Published by  
Infineon Technologies AG  
81726 Munich, Germany**

**© 2011 Infineon Technologies AG  
All Rights Reserved.**

### **Legal Disclaimer**

The information given in this document shall in no event be regarded as a guarantee of conditions or characteristics. With respect to any examples or hints given herein, any typical values stated herein and/or any information regarding the application of the device, Infineon Technologies hereby disclaims any and all warranties and liabilities of any kind, including without limitation, warranties of non-infringement of intellectual property rights of any third party.

### **Information**

For further information on technology, delivery terms and conditions and prices, please contact the nearest Infineon Technologies Office ([www.infineon.com](http://www.infineon.com)).

### **Warnings**

Due to technical requirements, components may contain dangerous substances. For information on the types in question, please contact the nearest Infineon Technologies Office.

Infineon Technologies components may be used in life-support devices or systems only with the express written approval of Infineon Technologies, if a failure of such components can reasonably be expected to cause the failure of that life-support device or system or to affect the safety or effectiveness of that device or system. Life support devices or systems are intended to be implanted in the human body or to support and/or maintain and sustain and/or protect human life. If they fail, it is reasonable to assume that the health of the user or other persons may be endangered.



单击下面可查看定价，库存，交付和生命周期等信息

[>>Infineon Technologies\(英飞凌\)](#)

[>>点击查看相关商品](#)