

# Microwave Coaxial Connectors



### **EU RoHS Compliant**

- All the products in this catalog comply with EU RoHS.
- EU RoHS is "the European Directive 2011/65/EU on the Restriction of the Use of Certain Hazardous Substances in Electrical and Electronic Equipment."
- For more details, please refer to our web page, "Murata's Approach for EU RoHS" (<https://www.murata.com/en-eu/support/compliance/rohs>).

# Contents

Product specifications are as of June 2018.

Part Numbering .....	p2
Type of Connectors .....	p4

## 1 Microwave Coaxial Connectors with Switch

SWD Type .....	p6
SWF Type .....	p8
SWG Type .....	p10
SWH Type .....	p12
SWH-2Way Type .....	p14
SWJ Type .....	p16

## 2 Microwave Coaxial Connectors

JSC Type .....	p18
KSC Type .....	p20
LSC Type .....	p22

## 3 Microwave Coaxial Board to Board Connectors

JSC Type .....	p24
KSC Type .....	p26
LSC Type .....	p28

Notice (Design) .....	p30
Notice (Engagement/Disengagement) .....	p31
Type of Probes .....	p32
Electrical Performance Measurement System (Insertion Loss, VSWR) .....	p33
Mechanical Performance Measurement System (Engagement/Disengagement Force) .....	p34
Notice .....	p35

Please check the MURATA website (<https://www.murata.com/>) if you cannot find a part number in this catalog.

● Part Numbering

Microwave Coaxial Connectors/Multi Connectors

(Part Number) 

MM	8930	-26	00	R	K0
①	②	③	④	⑤	⑥

① Product ID

Code	
<b>MM</b>	Microwave Coaxial Connectors/Multi Connectors (Chip Type Receptacle)

② Series

Code	Series
<b>5829</b>	JSC-Male Type
<b>5831</b>	JSC-Female Type
<b>6829</b>	KSC-Male Type
<b>6831</b>	KSC-Female Type
<b>7829</b>	LSC-Male Type
<b>7831</b>	LSC-Female Type
<b>8430</b>	SWD Type
<b>8130</b>	SWF Type
<b>8030</b>	SWG Type
<b>8930</b>	SWH Type
<b>8830</b>	SWJ Type

③ Individual Specification Code (1)

Code	Individual Specification Code (1)
<b>-26</b>	Switch Connector SMD Type
<b>-27</b>	Connector SMD Type

④ Individual Specification Code (2)

Code	Individual Specification Code (2)
<b>00</b>	Serial

⑤ Package Product ID

Code	Package Product ID
<b>B</b>	Bulk
<b>R</b>	Reel

\*You cannot order with Bulk for MP items.

⑥ Package Detail

Code	Package Detail
<b>A1</b>	SWD Type, 1000pcs./Reel (ø180mm)
<b>A2</b>	SWF Type, 2000pcs./Reel (ø180mm)
<b>B3</b>	SWD Type, 3000pcs./Reel (ø330mm)
<b>B8</b>	SWF Type, 8000pcs./Reel (ø330mm)
<b>J3</b>	SWG Type, 3000pcs./Reel (ø180mm)
<b>J4</b>	SWH, SWJ, JSC-Male, JSC-Female Type, 4000pcs./Reel (ø180mm)
<b>J5</b>	KSC-Male, KSC-Female, LSC-Male, LSC-Female, 5000pcs./Reel (ø180mm)
<b>K0</b>	SWG, SWH, JSC-Male, JSC-Male Type, 10000pcs./Reel (ø330mm)
<b>K15</b>	SWJ, JSC-Female Type, 15000pcs./Reel (ø330mm)
<b>K20</b>	KSC-Male, KSC-Female, LSC-Male, LSC-Female, 20000pcs./Reel (ø330mm)

### Microwave Coaxial Connectors with Cable

(Part Number)

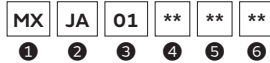

① Product ID

Code	
<b>MX</b>	Microwave Coaxial Connectors with Cable

② Connector (1)

Code	Connector (1)
<b>JA</b>	JSC Type for 01 Cable
<b>JG</b>	JSC Type for B3 Cable
<b>JF</b>	JSC Type for 56 Cable
<b>KG</b>	KSC Type for B3 Cable
<b>KF</b>	KSC Type for 56 Cable
<b>LA</b>	LSC Type for B3 Cable
<b>LF</b>	LSC Type for 56 Cable

③ Cable

Code	Cable
<b>01</b>	0.4D, PFA, Single Shield Line, Spiral
<b>B3</b>	0.2D, PFA, Single Shield Line, Spiral
<b>56</b>	0.3D, PFA, Single Shield Line, Spiral

④ Connector (2)

Code	Connector (2)
<b>JA</b>	JSC Type for 01 Cable
<b>JG</b>	JSC Type for B3 Cable
<b>JF</b>	JSC Type for 56 Cable
<b>KG</b>	KSC Type for B3 Cable
<b>KF</b>	KSC Type for 56 Cable
<b>LA</b>	LSC Type for B3 Cable
<b>LF</b>	LSC Type for 56 Cable
<b>XX</b>	None Connector

⑤ Length

Expressed by four figures. The unit is mm. From first to third figures are significant, and the fourth figure expresses the number of zeros which follow the three figures.

Ex.)

Code	Length
<b>5000</b>	500mm=500x10 <sup>0</sup>
<b>1001</b>	1000mm=100x10 <sup>1</sup>

⑥ Individual Specification Code

Code	Individual Specification Code
<b>**</b>	Expressed by two sign

## Type of Connectors

Murata offers a variety of connectors:

- Switch connector to measure RF circuit.
- Microwave coaxial cable connector to transmit high frequency signals between circuits with low loss.
- Board to Board connector to transmit high frequency signals from board to board with low loss.

### Microwave Coaxial Connectors with Switch

The RF circuit and ANT characteristics can be measured by mounting in an RF transmission line.

The internally built-in mechanical switch separates the RF circuit and ANT circuit, so that the circuit can be measured without any mutual effect using a dedicated probe made by Murata. Except when measuring with probe, internal mechanical switch is connected, so RF circuit and Antenna circuit are connected.

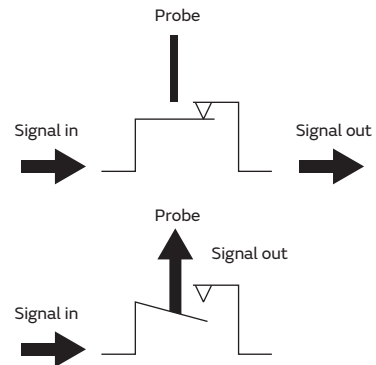
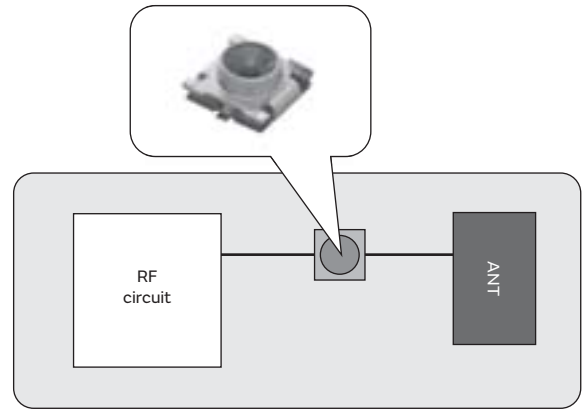

### Microwave Coaxial Connectors with Switch (bi-direction)

RF circuit and Antenna circuit can be measured by using special probe without remounting switch connector.

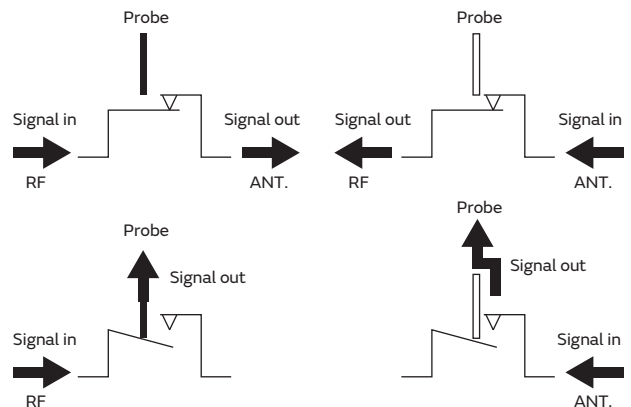
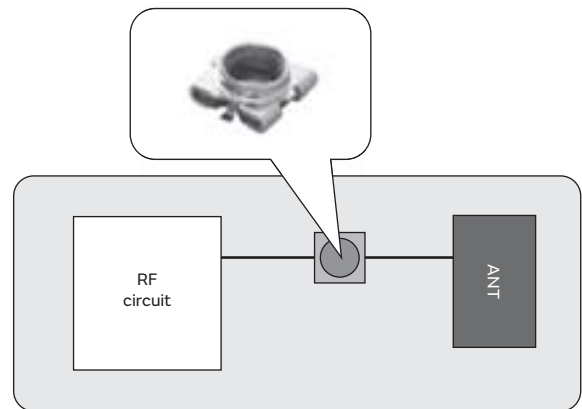

Continued on the following page. ↗

## Type of Connectors

Continued from the preceding page. ↘

### Microwave Coaxial Connectors with Cable

This connector transmits high frequency signals between circuits, and its transmission loss is lower than electrode pattern.

SMD type coaxial Connector and coaxial cable connector are used in a kit.

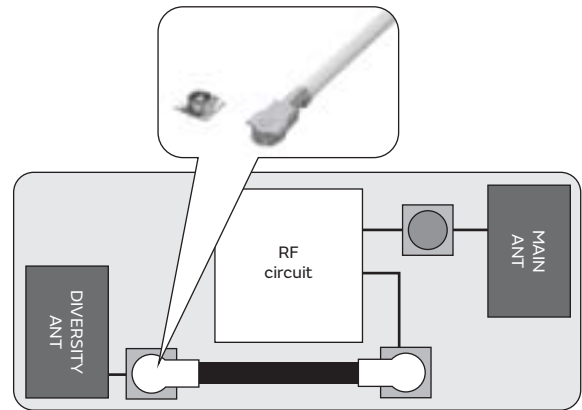

### Microwave Coaxial Board to Board Connectors

Board to Board connector to transmit high frequency signals from board to board, such as antenna and main board.

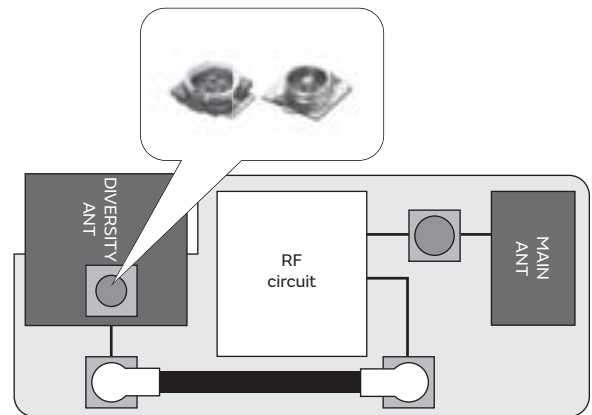

# Microwave Coaxial Connectors with Switch

## Microwave Coaxial Connectors with Switch SWD Type

### Features

1. The microwave coaxial connector with switch is very useful for electrical characteristics measurement of microwave circuits for PC, tablet, and cellular phone.
2. Size 3x3x1.75mm (LxWxH), Occupation area 9mm<sup>2</sup>
3. Excellent characteristics, IL 0.2dB max. (@6GHz), VSWR 1.3 max. (DC to 6GHz)
4. Connector durability is 500 cycles with probe.

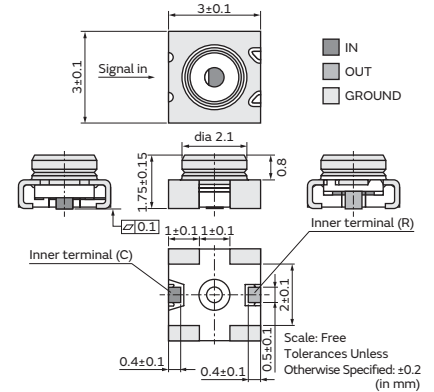

### Applications

PC, Tablet, Cellular phone, and Other wireless equipment

Part Number	Center Contact Resistance (mΩ max.)	Withstanding Voltage (Vrms)	Insulation Resistance (MΩ)	Durability (Cycle)	Nominal Frequency Range (GHz)	VSWR (dB max.)	Insertion Loss (On) (dB max.)	Isolation (Off) (dB min.)
<b>MM8430-2610</b>	50	300	500	500	to 6	1.2 (DC to 3GHz) 1.3 (3GHz to 6GHz)	0.1 (DC to 3GHz) 0.2 (3GHz to 6GHz)	20 (DC to 3GHz) 15 (3GHz to 6GHz)

Nominal Impedance: 50Ω  
 Rated Voltage: 30Vrms  
 Temperature Rating: -40 to 85°C

### Specification (Insertion Loss & VSWR)

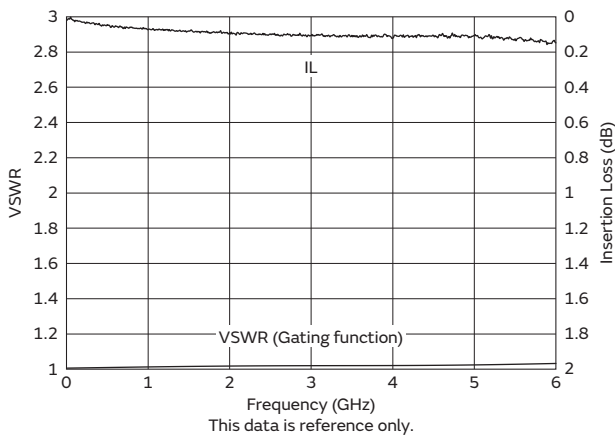

Measurement system: Refer to Electrical performance measurement system (p. 33)

### Standard Pattern Dimension, Stencil Mask Pattern

- I/O pattern should be designed to be the impedance match 50 ohm.
- The material of PWB is the epoxy resin of glass fabric base. ( $\epsilon_r=4.3@1\text{GHz}$ ). Thickness is 1.0mm.
- The solder resist should be printed except for the land pattern on the PWB
- Land pattern and solder resist pattern must be followed to avoid soldering defects.

#### Standard Pattern Dimensions

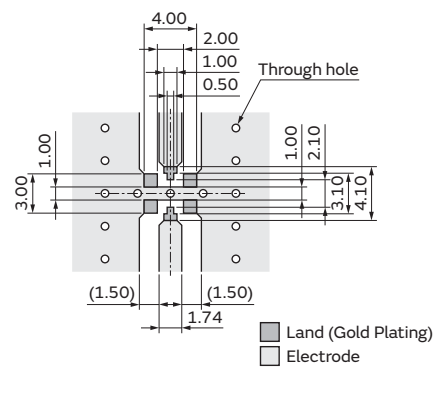

Continued on the following page. ↗



Continued from the preceding page. ↘

- There is the possibility to have the contact failure by flux shifting into contact point, if the excess solder is used by non-standard stencil mask pattern. Stencil mask pattern must be followed to avoid soldering defects.

**Standard Stencil Mask Pattern**

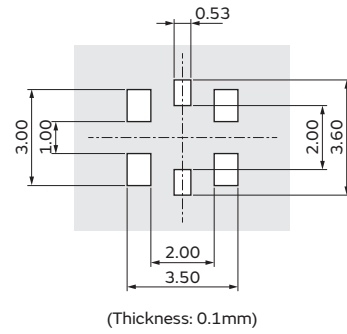

The standard solder cream stencil mask drawing (in mm)

**Dimensions of Reel**

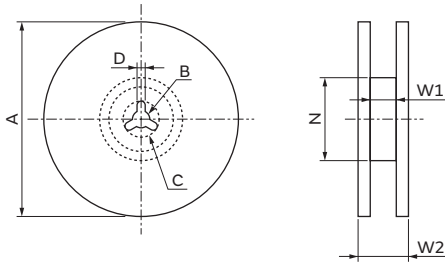

Part Number	A	B	C	D	N	W1	W2
MM8430-2610RA1	180+0/-3	13±0.5	21±0.8	2±0.5	Dia. 60+2/-0	13+2/-0	17±2
MM8430-2610RB3	330±2.0	13±0.5	21±0.8	2±0.5	Dia. (110)	13.4±2	17.4±2

(in mm)

**Dimensions of Taping**

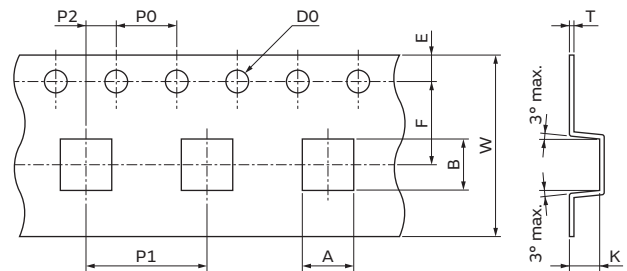

A	B	W	D0	E	F	K
3.4±0.1	3.4±0.1	12±0.2	Dia. 1.5±0.1	1.75±0.1	5.5±0.1	2.0±0.15

P0	P1	P2	T
4±0.1	8±0.1	2±0.1	0.3±0.05

(in mm)

**Minimum Quantity**

- MM8430-2610RA1: 180 mm dia. reel/1000 pcs.
- MM8430-2610RB3: 330 mm dia. reel/3000 pcs.

# Microwave Coaxial Connectors with Switch

## Microwave Coaxial Connectors with Switch SWF Type

### Features

1. The microwave coaxial connector with switch is very useful for electrical characteristics measurement of microwave circuit for PC, tablet and cellular phone.
2. Size 2.5x2.5x1.4mm (LxWxH), Occupation area 6.25mm<sup>2</sup>
3. Excellent characteristics, low IL 0.2dB max. (@6GHz)  
 V.S.W.R. 1.3 max. (DC to 6GHz)
4. Connector durability is 100 cycles with probe.

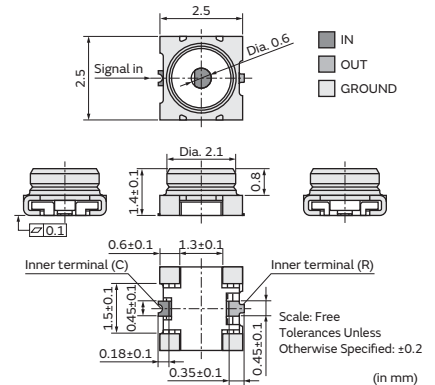

### Applications

PC, Tablet, Cellular phone and other wireless equipment

Part Number	Center Contact Resistance (mΩ max.)	Withstanding Voltage (Vrms)	Insulation Resistance (MΩ)	Durability (Cycle)	Nominal Frequency Range (GHz)	VSWR (dB max.)	Insertion Loss (On) (dB max.)	Isolation (Off) (dB min.)
<b>MM8130-2600</b>	70	300	500	100	to 6	1.2 (DC to 3GHz) 1.3 (3GHz to 6GHz)	0.1 (DC to 3GHz) 0.2 (3GHz to 6GHz)	20 (DC to 3GHz) 15 (3GHz to 6GHz)

Nominal Impedance: 50Ω  
 Rated Voltage: 30Vrms  
 Temperature Rating: -40 to 85°C

### Specification (Insertion Loss & VSWR)

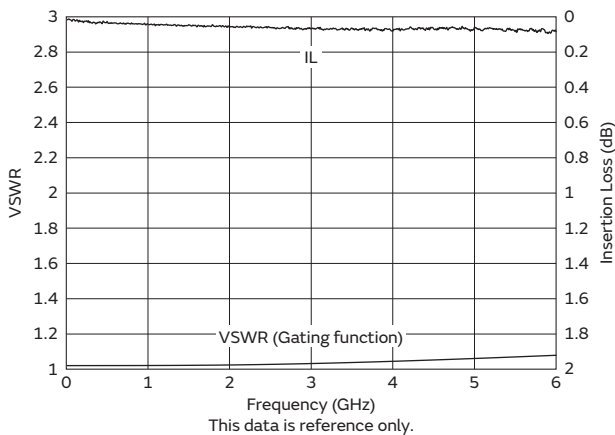

Measurement system: Refer to Electrical performance measurement system (p. 33)

### Standard Pattern Dimension, Stencil Mask Pattern

- I/O pattern should be designed to be the impedance match 50 ohm.
- The material of PWB is the epoxy resin of glass fabric base. (εr=4.3@1GHz). Thickness is 1.0mm.
- The solder resist should be printed except for the land pattern on the PWB
- Land pattern and solder resist pattern must be followed to avoid soldering defects.

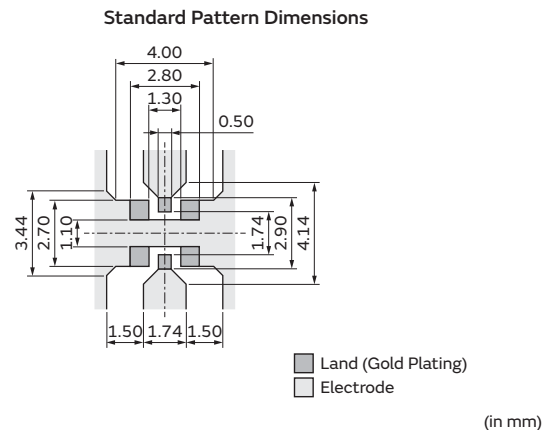

Continued on the following page. ↗

Continued from the preceding page. ↘

- There is the possibility to have the contact failure by flux shifting into contact point, if the excess solder is used by non-standard stencil mask pattern. Stencil mask pattern must be followed to avoid soldering defects.

**Standard Stencil Mask Pattern**

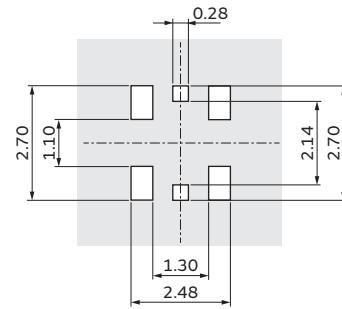

(Thickness: 0.12mm)

The standard solder cream stencil mask drawing

(in mm)

**Dimensions of Reel**

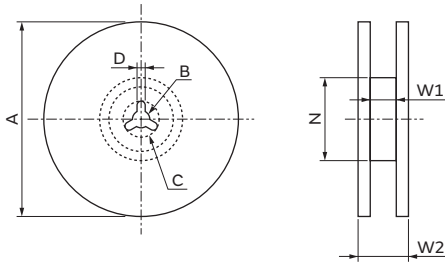

Part Number	A	B	C	D	N	W1	W2
MM8130-2600RA2	180+0/-3	13±0.5	21±0.8	2±0.5	Dia. 60+1/-0	9±0.3	11.4±1.0
MM8130-2600RB8	330±2.0	13±0.5	21±0.8	2±0.5	Dia. 100±1.0	9.4±1.0	13.4±1.0

(in mm)

**Dimensions of Taping**

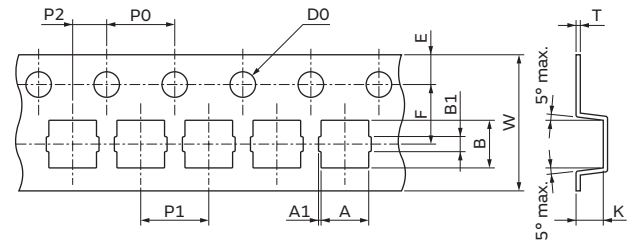

A	A1	B	B1	W	D0
2.8±0.1	0.15±0.1	2.8±0.1	0.85±0.1	8±0.2	Dia. 1.5±0.1

E	F	K	P0	P1	P2	T
1.75±0.1	3.5±0.1	1.6±0.1	4±0.1	4±0.1	2±0.1	0.25±0.05

(in mm)

**Minimum Quantity**

MM8130-2600RA2: 180 mm dia. reel/2000 pcs.

MM8130-2600RB8: 330 mm dia. reel/8000 pcs.

# Microwave Coaxial Connectors with Switch

## Microwave Coaxial Connectors with Switch SWG Type

### Features

1. The microwave coaxial connector with switch is very useful for electrical characteristics measurement of microwave circuit for PC, tablet and cellular phone.
2. Nominal Frequency Range is DC to 11GHz.
3. Size 2x2x0.9mm (LxWxH), Occupation area 4mm<sup>2</sup>
4. Excellent characteristics, low IL 0.2dB max. (@6GHz) and 0.5dB max. (@11GHz) V.S.W.R. 1.3 max. (DC to 6GHz) and 1.5 max. (6GHz to 11GHz)
5. Connector durability is 100 cycles with probe.

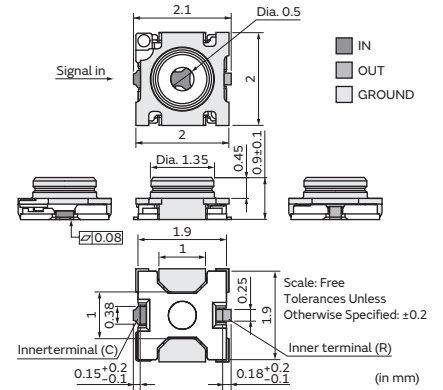

### Applications

PC, Tablet, Cellular phone and other wireless equipment

Part Number	Center Contact Resistance (mΩ max.)	Withstanding Voltage (Vrms)	Insulation Resistance (MΩ)	Durability (Cycle)	Nominal Frequency Range (GHz)	VSWR (dB max.)	Insertion Loss (On) (dB max.)	Isolation (Off) (dB min.)
<b>MM8030-2610</b>	70	300	500	100	to 11	1.2 (DC to 3GHz) 1.3 (3GHz to 6GHz) 1.5 (6GHz to 11GHz)	0.1 (DC to 3GHz) 0.2 (3GHz to 6GHz) 0.5 (6GHz to 11GHz)	20 (DC to 3GHz) 15 (3GHz to 6GHz) 10 (6GHz to 11GHz)

Nominal Impedance: 50Ω  
 Rated Voltage: 30Vrms  
 Temperature Rating: -40 to 85°C

### Specification (Insertion Loss & VSWR)

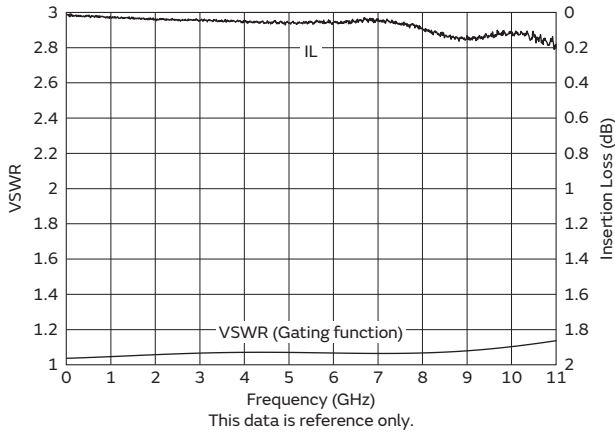

Measurement system: Refer to Electrical performance measurement system (p. 33)

### Standard Pattern Dimension, Stencil Mask Pattern

- I/O pattern should be designed to be the impedance match 50 ohm.
- The material of PWB is the epoxy resin of glass fabric base. ( $\epsilon_r=4.3@1\text{GHz}$ ). Thickness is 1.0mm.
- The solder resist should be printed except for the land pattern on the PWB
- Land pattern and solder resist pattern must be followed to avoid soldering defects.

Standard Pattern Dimensions

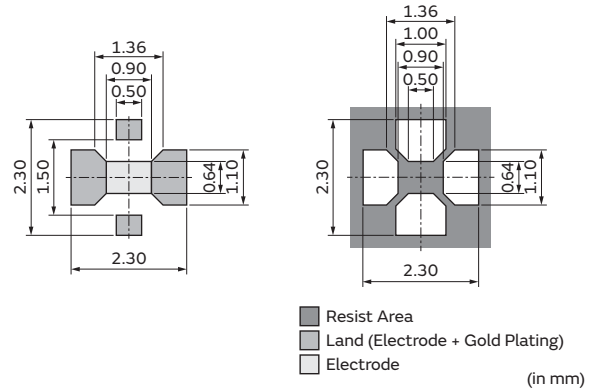

- There is the possibility to have the contact failure by flux shifting into contact point, if the excess solder is used by non-standard stencil mask pattern. Stencil mask pattern must be followed to avoid soldering defects.

Standard Stencil Mask Pattern

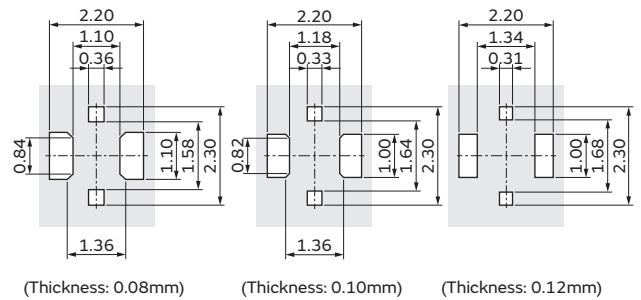

The standard solder cream stencil mask drawing (in mm)

### Dimensions of Reel

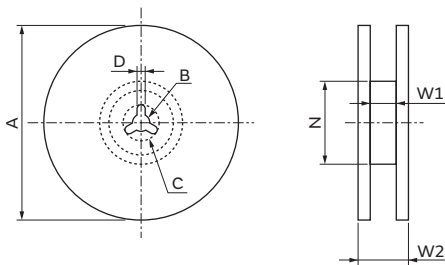

Part Number	A	B	C	D	N	W1	W2
MM8030-2610RJ3	180+0/-3	13±0.5	21±0.8	2±0.5	Dia. 60+1/-0	9±0.3	11.4±1.0
MM8030-2610RK0	330±2.0	13±0.5	21±0.8	2±0.5	Dia. 100±1.0	9.4±1.0	13.4±1.0

(in mm)

### Dimensions of Taping

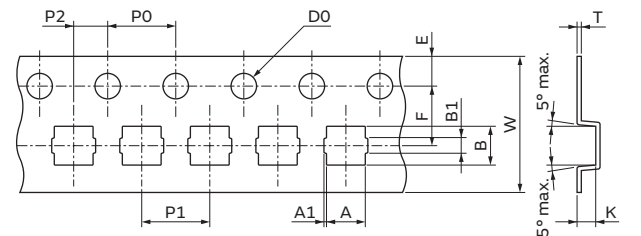

A	A1	B	B1	W	D0
2.28±0.1	0.15±0.1	2.28±0.1	0.85±0.1	8±0.2	Dia. 1.5±0.1

E	F	K	P0	P1	P2	T
1.75±0.1	3.5±0.1	1.1±0.1	4±0.1	4±0.1	2±0.1	0.25±0.05

(in mm)

### Minimum Quantity

- MM8030-2610RJ3: 180 mm dia. reel/3000 pcs.
- MM8030-2610RK0: 330 mm dia. reel/10000 pcs.

# Microwave Coaxial Connectors with Switch

## Microwave Coaxial Connectors with Switch SWH Type

### Features

1. The microwave coaxial connector with switch is very useful for electrical characteristics measurement of microwave circuit for cellular phone and small wireless equipment such as wearable equipment.
2. Size 1.6x1.6x0.7mm (LxWxH), Occupation area 2.56mm<sup>2</sup>
3. Excellent characteristics, low IL 0.2dB max. (@6GHz)  
 V.S.W.R. 1.3 max. (DC to 6GHz)
4. Connector durability is 50 cycles with probe.

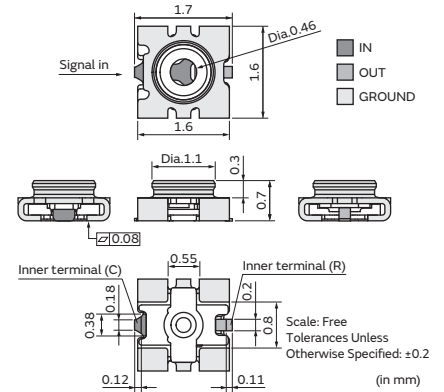

### Applications

Cellular phone, Wearable equipment and other wireless equipment

Part Number	Center Contact Resistance (mΩ max.)	Withstanding Voltage (Vrms)	Insulation Resistance (MΩ)	Durability (Cycle)	Nominal Frequency Range (GHz)	VSWR (dB max.)	Insertion Loss (On) (dB max.)	Isolation (Off) (dB min.)
<b>MM8930-2600</b>	70	200	500	50	to 6	1.2 (DC to 3GHz) 1.3 (3GHz to 6GHz)	0.1 (DC to 3GHz) 0.2 (3GHz to 6GHz)	20 (DC to 3GHz) 15 (3GHz to 6GHz)

Nominal Impedance: 50Ω  
 Rated Voltage: 30Vrms  
 Temperature Rating: -40 to 85°C

### Specification (Insertion Loss & VSWR)

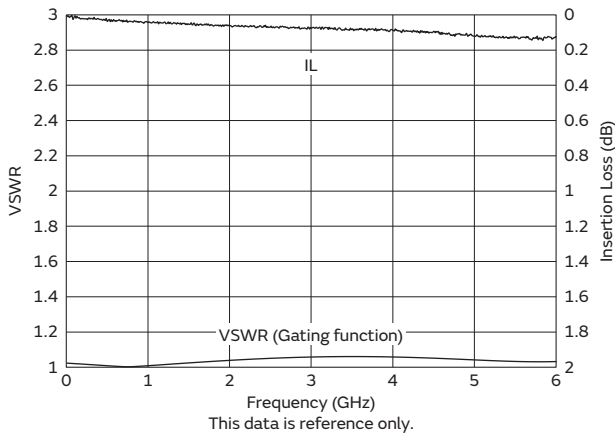

Measurement system: Refer to electrical performance measurement system (p. 33)

### Standard Pattern Dimension, Stencil Mask Pattern

- I/O pattern should be designed to be the impedance match 50 ohm.
- The material of PWB is the epoxy resin of glass fabric base. ( $\epsilon_r=4.3@1\text{GHz}$ ). Thickness is 0.4mm.
- The solder resist should be printed except for the land pattern on the PWB
- Land pattern and solder resist pattern must be followed to avoid soldering defects.

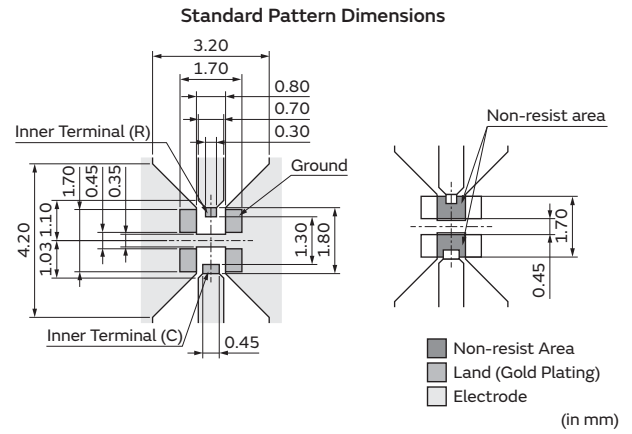

- There is the possibility to have the contact failure by flux shifting into contact point, if the excess solder is used by non-standard stencil mask pattern. Stencil mask pattern must be followed to avoid soldering defects.

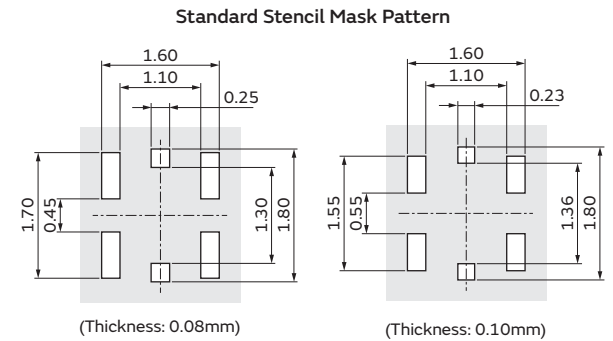

The standard solder cream stencil mask drawing

(in mm)

### Dimensions of Reel

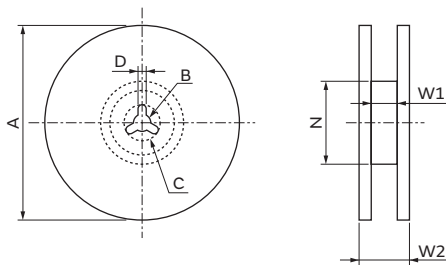

Part Number	A	B	C	D	N	W1	W2
MM8930-2600RJ4	180+0/-3	13±0.5	21±0.8	2±0.5	Dia. 60+1/-0	9±0.3	11.4±1.0
MM8930-2600RK0	330±2.0	13±0.5	21±0.8	2±0.5	Dia. 100±1.0	9.4±1.0	13.4±1.0

(in mm)

### Dimensions of Taping

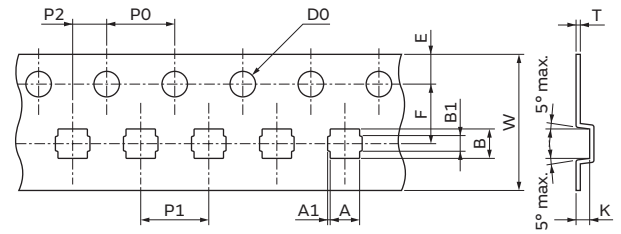

A	A1	B	B1	W	D0
1.73±0.1	0.14±0.1	1.73±0.1	0.8±0.2	8±0.2	Dia. 1.5±0.1

E	F	K	P0	P1	P2	T
1.75±0.1	3.5±0.1	0.8±0.1	4±0.1	4±0.1	2±0.1	0.25±0.05

(in mm)

### Minimum Quantity

- MM8930-2600RJ4: 180 mm dia. reel/4000 pcs.
- MM8930-2600RK0: 330 mm dia. reel/10000 pcs.

# Microwave Coaxial Connectors with Switch

## Microwave Coaxial Connectors with Switch SWH-2Way Type

### Features

1. The microwave 2way (bi-directional) coaxial connector with switch is very useful for electrical characteristics measurement of microwave circuit for cellular phone and small wireless equipment such as wearable equipment.
2. It is possible to measure ANT circuit and RF circuit with designated probe.
3. Size 1.6x1.6x0.7mm (LxWxH), Occupation area 2.56mm<sup>2</sup>
4. Excellent characteristics, low IL 0.2dB max. (@6GHz)  
V.S.W.R. 1.3 max. (DC to 6GHz)
5. Connector durability is 50 cycles with probe.

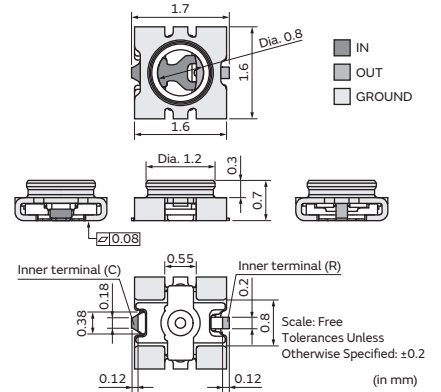

### Applications

Cellular phone, Wearable equipment and other wireless equipment

Part Number	Center Contact Resistance (mΩ max.)	Withstanding Voltage (Vrms)	Insulation Resistance (MΩ)	Durability (Cycle)	Nominal Frequency Range (GHz)	VSWR (dB max.)	Insertion Loss (On) (dB max.)	Isolation (Off) (dB min.)
<b>MM8930-2620</b>	70	200	500	50	to 6	1.2 (DC to 3GHz) 1.3 (3GHz to 6GHz)	0.1 (DC to 3GHz) 0.2 (3GHz to 6GHz)	RF: 20 (DC to 3GHz) RF: 15 (3GHz to 6GHz) ANT: 18 (DC to 3GHz) ANT: 13 (3GHz to 6GHz)

Nominal Impedance: 50Ω  
 Rated Voltage: 30Vrms  
 Temperature Rating: -40 to 85°C

### Specification (Insertion Loss & VSWR)

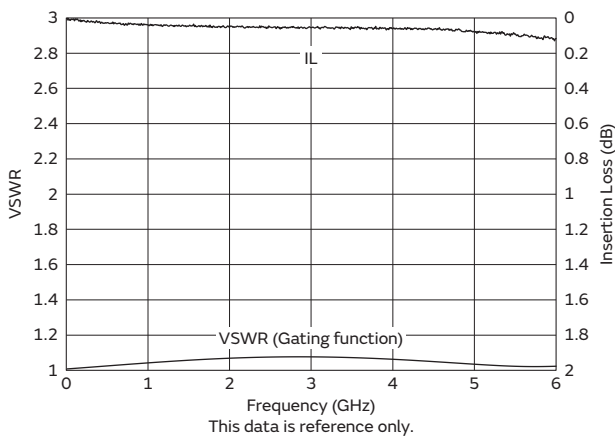

Measurement system: Refer to electrical performance measurement system (p. 33)



### Standard Pattern Dimension, Stencil Mask Pattern

- I/O pattern should be designed to be the impedance match 50 ohm.
- The material of PWB is the epoxy resin of glass fabric base. ( $\epsilon_r=4.3@1\text{GHz}$ ). Thickness is 0.4mm.
- The solder resist should be printed except for the land pattern on the PWB
- Land pattern and solder resist pattern must be followed to avoid soldering defects.

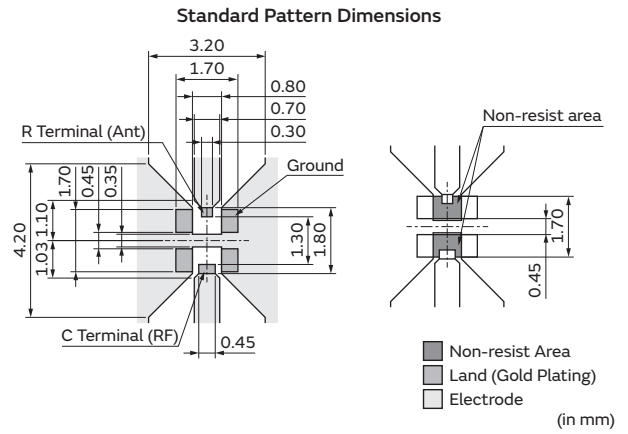

- There is the possibility to have the contact failure by flux shifting into contact point, if the excess solder is used by non-standard stencil mask pattern. Stencil mask pattern must be followed to avoid soldering defects.

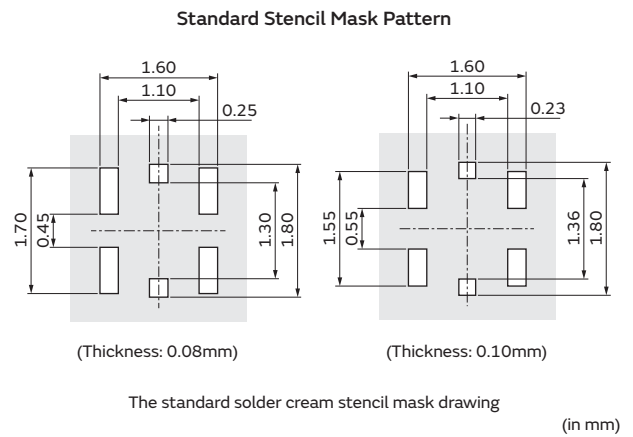

### Dimensions of Reel

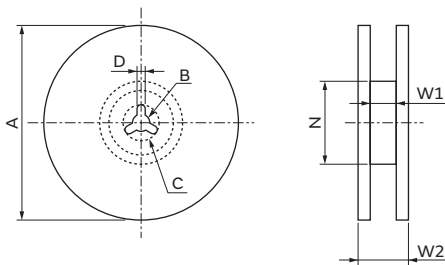

Part Number	A	B	C	D	N	W1	W2
MM8930-2620RJ4	180+0/-3	13±0.5	21±0.8	2±0.5	Dia. 60+1/-0	9±0.3	11.4±1.0
MM8930-2620RK15	330±2.0	13±0.5	21±0.8	2±0.5	Dia. 100±1.0	9.4±1.0	13.4±1.0

(in mm)

### Dimensions of Taping

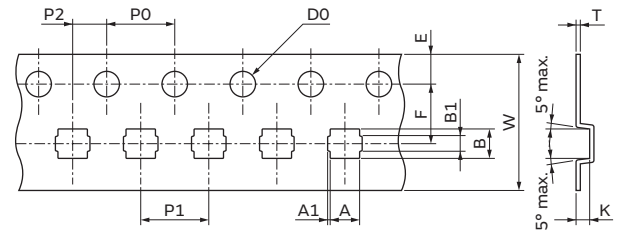

A	A1	B	B1	W	D0
1.73±0.1	0.14±0.1	1.73±0.1	0.8±0.2	8±0.2	Dia. 1.5±0.1

E	F	K	P0	P1	P2	T
1.75±0.1	3.5±0.1	0.8±0.1	4±0.1	4±0.1	2±0.1	0.25±0.05

(in mm)

### Minimum Quantity

MM8930-2620RJ4: 180 mm dia. reel/4000 pcs.  
 MM8930-2620RK15: 330 mm dia. reel/15000 pcs.

# Microwave Coaxial Connectors with Switch

## Microwave Coaxial Connectors with Switch SWJ Type

### Features

1. The worlds smallest level microwave coaxial connector with switch is very useful for electrical characteristics measurement of microwave circuit for cellular phone and small wireless equipment such as wearable equipment.
2. Size 1.4x1.2x0.65mm (LxWxH), Occupation area 1.68mm<sup>2</sup>
3. Excellent characteristics, low IL 0.2dB max. (@6GHz)  
 V.S.W.R. 1.3 max. (DC to 6GHz)
4. Connector durability is 50 cycles with probe.

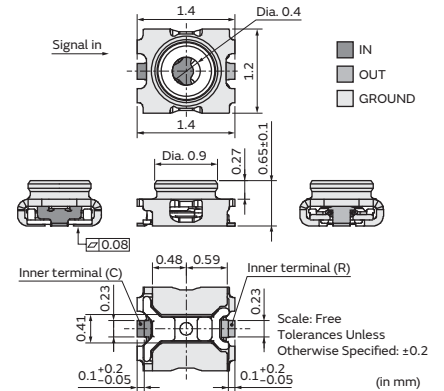

### Applications

Cellular phone, Wearable equipment and other wireless equipment

Part Number	Center Contact Resistance (mΩ max.)	Withstanding Voltage (Vrms)	Insulation Resistance (MΩ)	Durability (Cycle)	Nominal Frequency Range (GHz)	VSWR (dB max.)	Insertion Loss (On) (dB max.)	Isolation (Off) (dB min.)
<b>MM8830-2600</b>	70	200	500	50	to 6	1.2 (DC to 3GHz) 1.3 (3GHz to 6GHz)	0.1 (DC to 3GHz) 0.2 (3GHz to 6GHz)	20 (DC to 3GHz) 15 (3GHz to 6GHz)

Nominal Impedance: 50Ω  
 Rated Voltage: 30Vrms  
 Temperature Rating: -40 to 85°C

### Specification (Insertion Loss & VSWR)

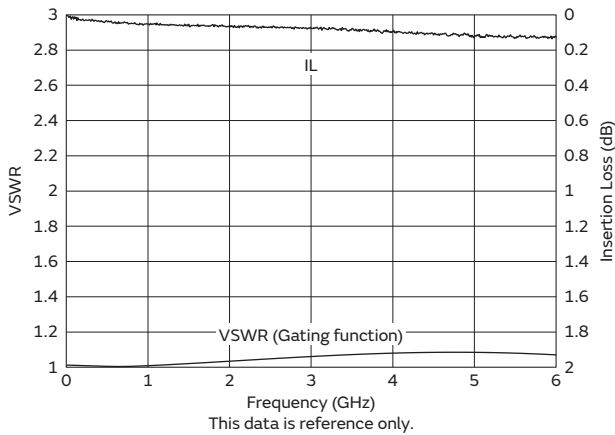

Measurement system: Refer to electrical performance measurement system (p. 33)

### Standard Pattern Dimension, Stencil Mask Pattern

- I/O pattern should be designed to be the impedance match 50 ohm.
- The material of PWB is the epoxy resin of glass fabric base. (εr=4.3@1GHz). Thickness is 0.4mm.
- The solder resist should be printed except for the land pattern on the PWB
- Land pattern and solder resist pattern must be followed to avoid soldering defects.

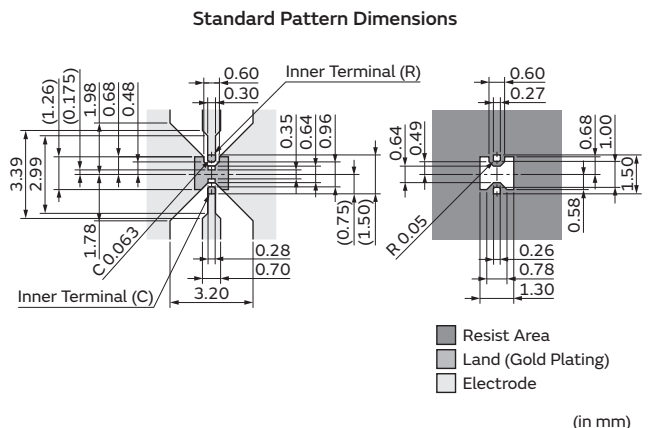

Continued on the following page. ↗

Continued from the preceding page. ↘

- There is the possibility to have the contact failure by flux shifting into contact point, if the excess solder is used by non-standard stencil mask pattern. Stencil mask pattern must be followed to avoid soldering defects.

**Standard Stencil Mask Pattern**

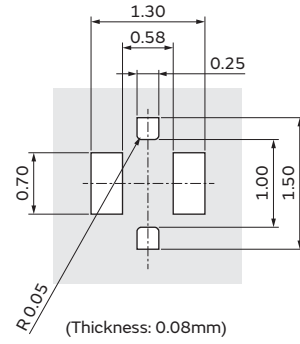

The standard solder cream stencil mask drawing (in mm)

**Dimensions of Reel**

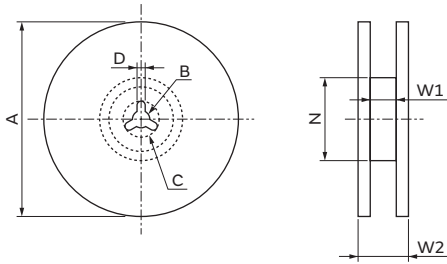

Part Number	A	B	C	D	N	W1	W2
MM8830-2600RJ4	180+0/-3	13±0.5	21±0.8	2±0.5	Dia. 60+1/-0	9±0.3	11.4±1.0
MM8830-2600RK15	330±2.0	13±0.5	21±0.8	2±0.5	Dia. 100±1.0	9.4±1.0	13.4±1.0

(in mm)

**Dimensions of Taping**

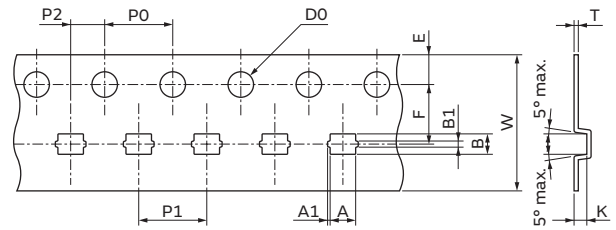

A	A1	B	B1	W	D0
1.5±0.1	0.14±0.1	1.3±0.1	0.29±0.1	8±0.2	Dia. 1.5±0.1

E	F	K	P0	P1	P2	T
1.75±0.1	3.5±0.1	0.75±0.1	4±0.1	4±0.1	2±0.1	0.25±0.05

(in mm)

**Minimum Quantity**

- MM8830-2600RJ4: 180 mm dia. reel/4000 pcs.
- MM8830-2600RK15: 330 mm dia. reel/15000 pcs.

# Microwave Coaxial Connectors

## Microwave Coaxial Connectors JSC Type

2

### Features

1. The microwave coaxial connector with cables is small, thin and suitable for internal wiring of cellular phone and small wireless equipment such as wearable equipment.
2. Nominal Frequency Range is DC to 12GHz. (01 type cable.)
3. Receptacle size 2x1.8 (LxW), Occupation area 3.6mm<sup>2</sup>
4. Mating height is 1.0mm max., which is the worlds lowest profile level with cable and receptacle.
5. V.S.W.R. 1.4 max. (DC to 6GHz), 1.6 max. (6GHz to 12GHz)
6. This has good lock feeling when cable and receptacle are mated.

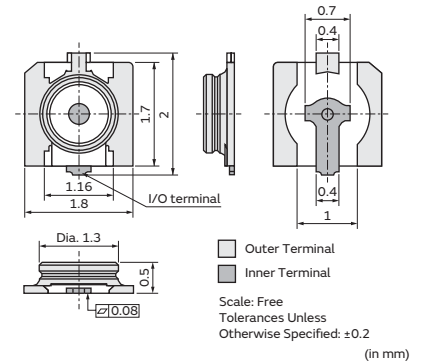

### Applications

Cellular phone, Wearable equipment and other wireless equipment

Part Number	Center Contact Resistance (mΩ max.)	Withstanding Voltage (Vrms)	Insulation Resistance (MΩ)	Durability (Cycle)	Nominal Frequency Range (GHz)	VSWR (dB max.)
MM5829-2700	35	200	500	30	to 12	1.3 (DC to 3GHz) 1.4 (3GHz to 6GHz) 1.5 (6GHz to 9GHz) 1.6 (9GHz to 12GHz)

Nominal Impedance: 50Ω  
 Rated Voltage: 30Vrms  
 Temperature Rating: -40 to 85°C

### Specification (Insertion Loss & VSWR)

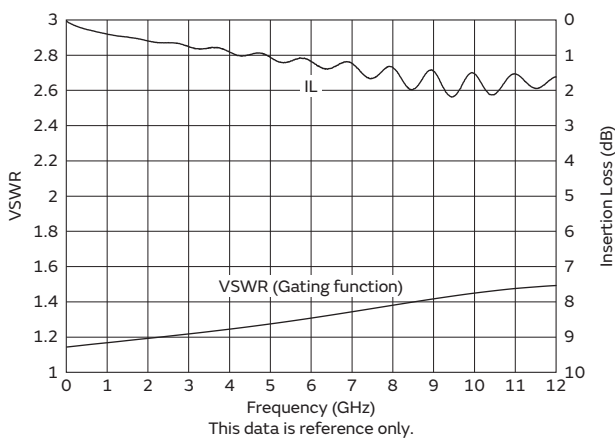

Measurement system: Refer to electrical performance measurement system (p. 33)  
 Cable part number of specification: MXJA01JA1000  
 Cable type of specification: 01  
 Cable length of specification: 100mm  
 Measurement condition: Cable + Receptacle

## Standard Pattern Dimension, Stencil Mask Pattern

- I/O pattern should be designed to be the impedance match 50 ohm.
- The material of PWB is the epoxy resin of glass fabric base. ( $\epsilon_r=4.3@1\text{GHz}$ ). Thickness is 1.0mm.
- The solder resist should be printed except for the land pattern on the PWB
- Land pattern and solder resist pattern must be followed to avoid soldering defects.

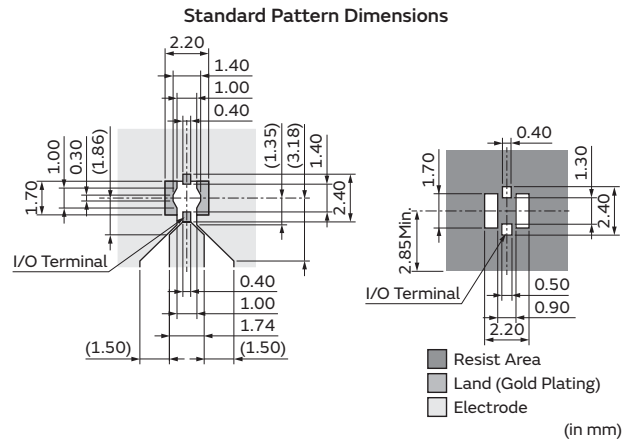

- There is the possibility to have the contact failure by flux shifting into contact point, if the excess solder is used by non-standard stencil mask pattern. Stencil mask pattern must be followed to avoid soldering defects.

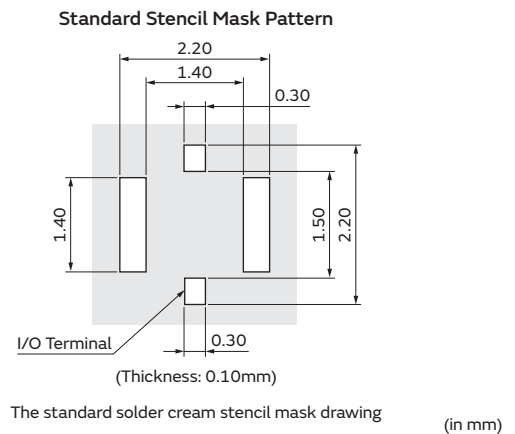

## Dimensions of Reel

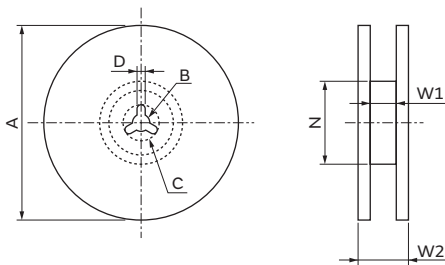

Part Number	A	B	C	D	N	W1	W2
MM5829-2700RJ4	180+0/-3	13±0.2	21±0.8	2±0.5	Dia. 60+1/-0	9±0.3	11.4±1.0
MM5829-2700RK0	330±2.0	13±0.2	21±0.8	2±0.5	Dia. 100±1.0	9.4±1.0	13.4±1.0

(in mm)

## Dimensions of Taping

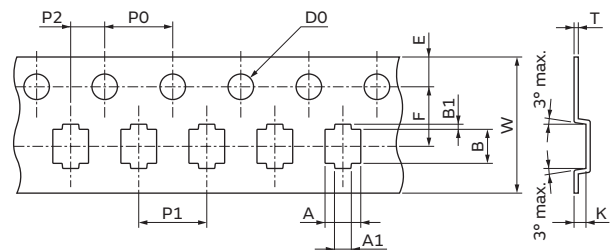

A	A1	B	B1	W	DO	
2.1±0.1	0.9±0.1	2.0±0.1	0.3±0.1	8±0.2	Dia. 1.5+0.1/-0	
E	F	K	P0	P1	P2	T
1.75±0.1	3.5±0.1	0.7±0.1	4±0.1	4±0.1	2±0.1	0.2±0.05

(in mm)

## Minimum Quantity

- MM5829-2700RJ4: 180 mm dia. reel/4000 pcs.  
 MM5829-2700RK0: 330 mm dia. reel/10000 pcs.

# Microwave Coaxial Connectors

## Microwave Coaxial Connectors KSC Type

2

### Features

1. This worlds smallest level microwave coaxial connector with cables is thin and suitable for internal wiring of cellular phone and small wireless equipment such as wearable equipment.
2. Receptacle size 1.3x1.2 (LxW), Occupation area 1.56mm<sup>2</sup>
3. Mating height is 0.8mm max., which is world lowest profile level, with cable and receptacle.
4. V.S.W.R. 1.4 max. (DC to 6GHz)
5. This has good lock feeling when cable and receptacle are mated.

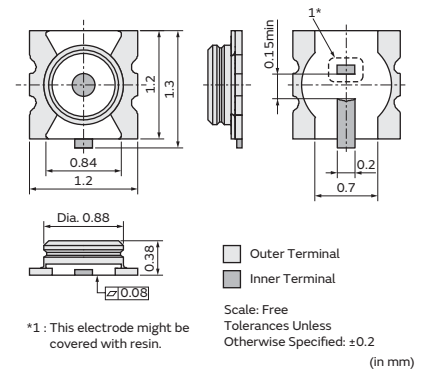

### Applications

Cellular phone, Wearable equipment and other wireless equipment

Part Number	Center Contact Resistance (mΩ max.)	Withstanding Voltage (Vrms)	Insulation Resistance (MΩ)	Durability (Cycle)	Nominal Frequency Range (GHz)	VSWR (dB max.)
MM6829-2700	35	200	500	30	to 6	1.3 (DC to 3GHz) 1.4 (3GHz to 6GHz)

Nominal Impedance: 50Ω  
 Rated Voltage: 30Vrms  
 Temperature Rating: -40 to 85°C

### Specification (Insertion Loss & VSWR)

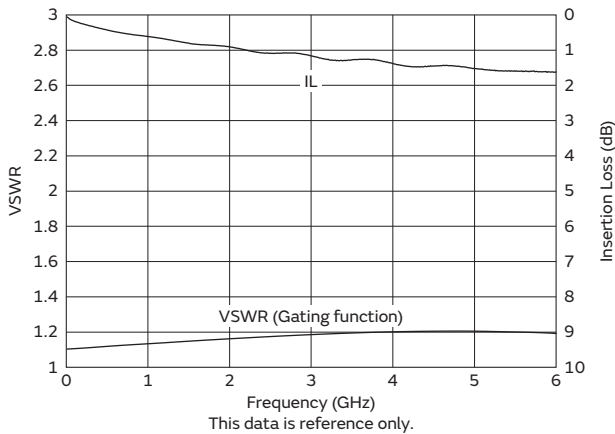

Measurement system: Refer to electrical performance measurement system (p. 33)  
 Cable part number of specification: MXKGB3KG1000  
 Cable type of specification: B3  
 Cable length of specification: 100mm  
 Measurement condition: Cable + Receptacle

### Standard Pattern Dimension, Stencil Mask Pattern

- I/O pattern should be designed to be the impedance match 50 ohm.
- The material of PWB is the epoxy resin of glass fabric base. ( $\epsilon_r=4.3@1\text{GHz}$ ). Thickness is 0.4mm.
- The solder resist should be printed except for the land pattern on the PWB
- Land pattern and solder resist pattern must be followed to avoid soldering defects.

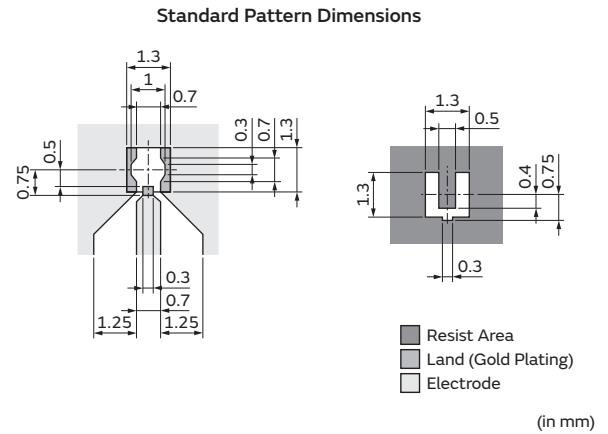

- There is the possibility to have the contact failure by flux shifting into contact point, if the excess solder is used by non-standard stencil mask pattern. Stencil mask pattern must be followed to avoid soldering defects.

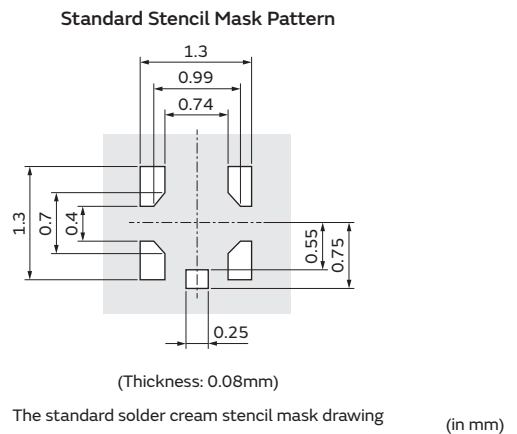

### Dimensions of Reel

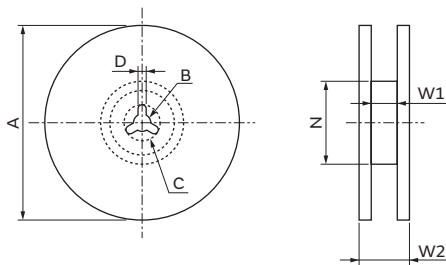

Part Number	A	B	C	D	N	W1	W2
MM6829-2700RJ5	180+0/-3	13±0.2	21±0.8	2±0.5	Dia. 60+1/-0	9±0.3	11.4±1.0
MM6829-2700RK20	330±2.0	13±0.2	21±0.8	2±0.5	Dia. 100±1.0	9.4±1.0	13.4±1.0

(in mm)

### Dimensions of Taping

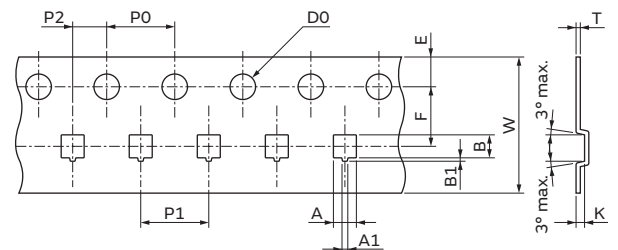

A	A1	B	B1	W	DO
1.35±0.1	0.29±0.1	1.35±0.1	0.2±0.1	8±0.2	Dia. 1.5+0.1/-0

E	F	K	P0	P1	P2	T
1.75±0.1	3.5±0.1	0.5±0.05	4±0.1	4±0.1	2±0.1	0.2±0.1

(in mm)

### Minimum Quantity

- MM6829-2700RJ5: 180 mm dia. reel/5000 pcs.
- MM6829-2700RK20: 330 mm dia. reel/20000 pcs.

# Microwave Coaxial Connectors

## Microwave Coaxial Connectors LSC Type

2

### Features

1. The microwave coaxial connector with cables is small, thin and suitable for internal wiring of cellular phone and small wireless equipment such as wearable equipment.
2. Receptacle size 1.7x1.6 (LxW), Occupation area 2.72mm<sup>2</sup>
3. Mating height is 0.8mm max., which is world lowest profile level, with cable and receptacle.
4. Diameter of receptacle cylinder is equal size with JSC type connector. It makes easy to mate cable and connector.
5. V.S.W.R. 1.4 max. (DC to 6GHz)
6. This has good lock feeling when cable and receptacle are mated.

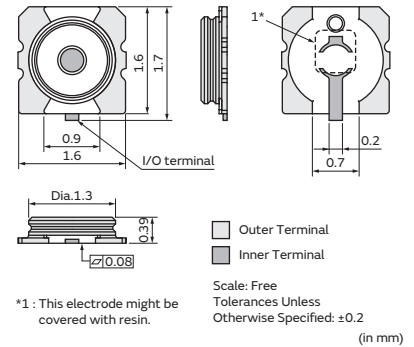

### Applications

Cellular phone, Wearable equipment and other wireless equipment

Part Number	Center Contact Resistance (mΩ max.)	Withstanding Voltage (Vrms)	Insulation Resistance (MΩ)	Durability (Cycle)	Nominal Frequency Range (GHz)	VSWR (dB max.)
MM7829-2700	35	200	500	30	to 6	1.3 (DC to 3GHz) 1.4 (3GHz to 6GHz)

Nominal Impedance: 50Ω  
 Rated Voltage: 30Vrms  
 Temperature Rating: -40 to 85°C

### Specification (Insertion Loss & VSWR)

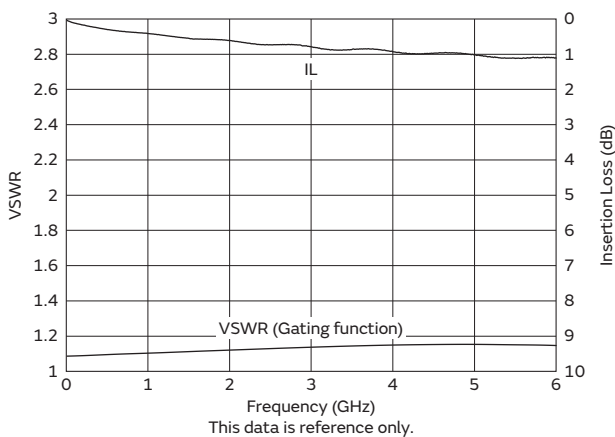

Measurement system: Refer to electrical performance measurement system (p. 33)  
 Cable part number of specification: MXLF56LF1000  
 Cable type of specification: 56  
 Cable length of specification: 100mm  
 Measurement condition: Cable + Receptacle



### Standard Pattern Dimension, Stencil Mask Pattern

- I/O pattern should be designed to be the impedance match 50 ohm.
- The material of PWB is the epoxy resin of glass fabric base. ( $\epsilon_r=4.3@1\text{GHz}$ ). Thickness is 0.4mm.
- The solder resist should be printed except for the land pattern on the PWB
- Land pattern and solder resist pattern must be followed to avoid soldering defects.

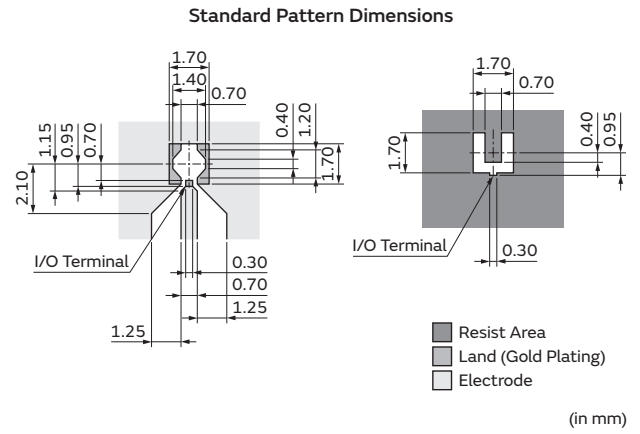

- There is the possibility to have the contact failure by flux shifting into contact point, if the excess solder is used by non-standard stencil mask pattern. Stencil mask pattern must be followed to avoid soldering defects.

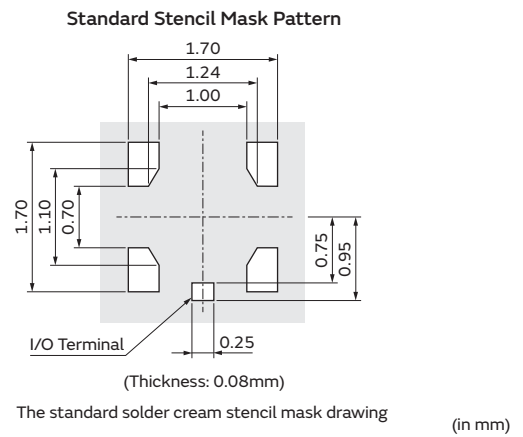

### Dimensions of Reel

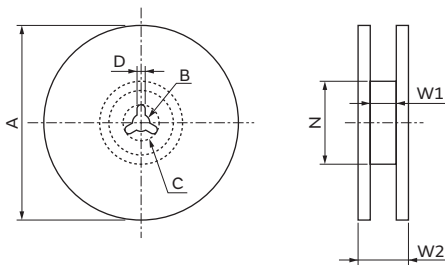

Part Number	A	B	C	D	N	W1	W2
MM7829-2700RJ5	180+0/-3	13±0.2	21±0.8	2±0.5	Dia. 60+1/-0	9±0.3	11.4±1.0
MM7829-2700RK20	330±2.0	13±0.2	21±0.8	2±0.5	Dia. 100±1.0	9.4±1.0	13.4±1.0

(in mm)

### Dimensions of Taping

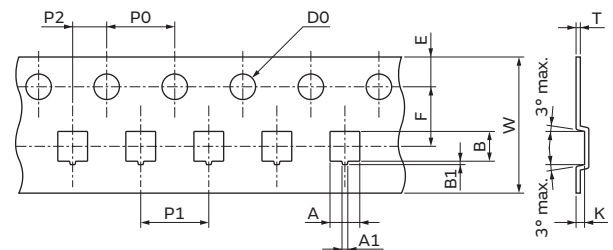

A	A1	B	B1	W	D0
1.75±0.1	0.29±0.1	1.75±0.1	0.2±0.05	8±0.2	Dia. 1.5+0.1/-0

E	F	K	P0	P1	P2	T
1.75±0.1	3.5±0.05	0.5±0.05	4±0.1	4±0.1	2±0.1	0.2±0.05

(in mm)

### Minimum Quantity

- MM7829-2700RJ5: 180 mm dia. reel/5000 pcs.
- MM7829-2700RK20: 330 mm dia. reel/20000 pcs.

# Microwave Coaxial Board to Board Connectors

## Microwave Coaxial Board to Board Connectors JSC Type

### Features

1. The microwave coaxial Board to Board connector is small, thin and suitable for internal wiring of cellular phone and small wireless equipment such as wearable equipment.
2. Receptacle size 2x1.8 (LxW), Occupation area 3.6mm<sup>2</sup>. Plug receptacle size 2x2.2 (LxW), Occupation area 4.4mm<sup>2</sup>
3. Mating height is 0.8mm max., which is worlds lowest profile level, with plug receptacle and receptacle.
4. V.S.W.R. 1.5 max. (DC to 6GHz)
5. This has good lock feeling when plug receptacle and receptacle are mated.
6. This connector mate with MM5829-2700.

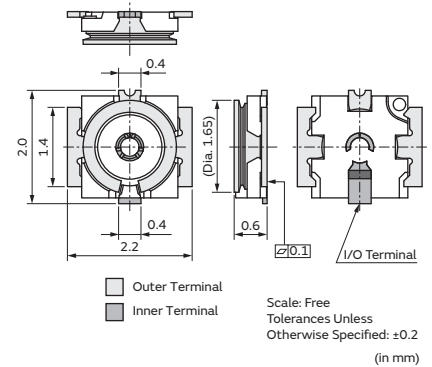

### Applications

Cellular phone, Wearable equipment and other wireless equipment

Part Number	Center Contact Resistance (mΩ max.)	Withstanding Voltage (Vrms)	Insulation Resistance (MΩ)	Durability (Cycle)	Nominal Frequency Range (GHz)	VSWR (dB max.)
MM5831-2700	35	200	500	30	to 6	1.3 (DC to 3GHz) 1.5 (3GHz to 6GHz)

Nominal Impedance: 50Ω  
 Rated Voltage: 30Vrms  
 Temperature Rating: -40 to 85°C

### Specification (Insertion Loss & VSWR)

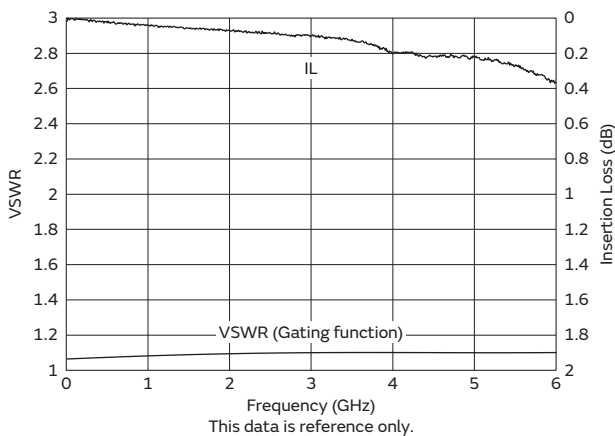

Measurement system: Refer to electrical performance measurement system (p. 33)  
 Measurement condition: SMD plug + Receptacle

### Standard Pattern Dimension, Stencil Mask Pattern

- I/O pattern should be designed to be the impedance match 50 ohm.
- The material of PWB is the epoxy resin of glass fabric base. ( $\epsilon_r=4.3@1\text{GHz}$ ). Thickness is 1.0mm.
- The solder resist should be printed except for the land pattern on the PWB
- Land pattern and Solder resist pattern must be followed to avoid soldering defects.

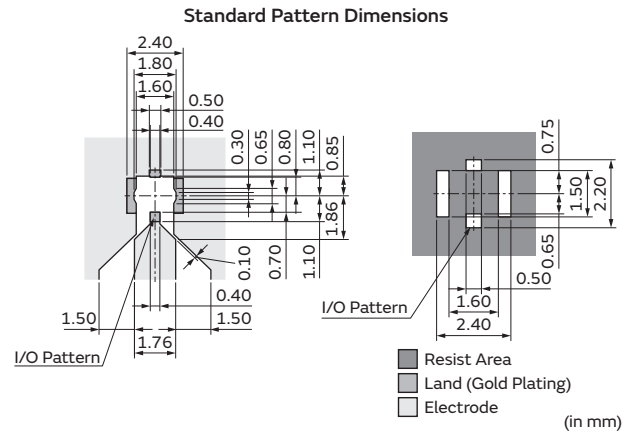

- There is the possibility to have the contact failure by flux shifting into contact point, if the excess solder is used by non-standard stencil mask pattern. Stencil mask pattern must be followed to avoid soldering defects.

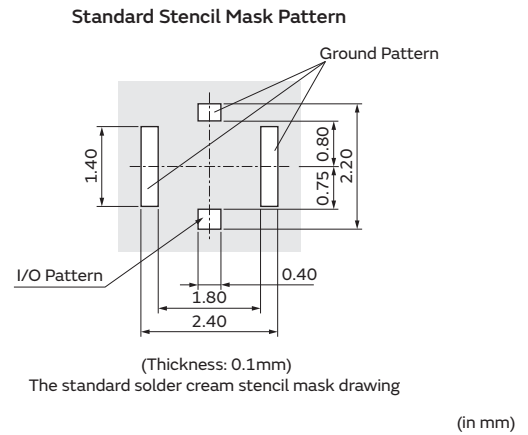

### Dimensions of Reel

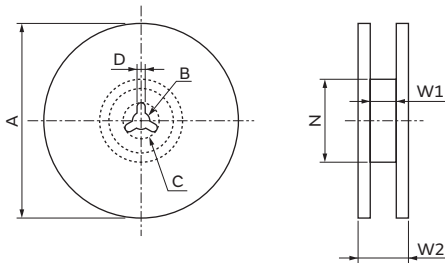

Part Number	A	B	C	D	N	W1	W2
MM5831-2700RJ4	180 $\pm$ 0/-3	13 $\pm$ 0.2	21 $\pm$ 0.8	2 $\pm$ 0.5	Dia. 60 $\pm$ 1/-0	9 $\pm$ 0.3	11.4 $\pm$ 1.0
MM5831-2700RK15	330 $\pm$ 2.0	13 $\pm$ 0.2	21 $\pm$ 0.8	2 $\pm$ 0.5	Dia. 100 $\pm$ 1.0	9.4 $\pm$ 1.0	13.4 $\pm$ 1.0

(in mm)

### Dimensions of Taping

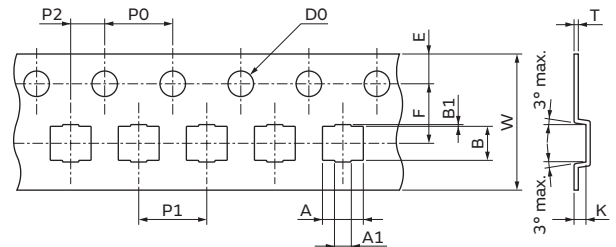

A	A1	B	B1	W	DO
2.4 $\pm$ 0.1	0.6 $\pm$ 0.1	2.0 $\pm$ 0.1	0.1 $\pm$ 0.1	8 $\pm$ 0.2	Dia. 1.5 $\pm$ 0.1/-0

E	F	K	P0	P1	P2	T
1.75 $\pm$ 0.1	3.5 $\pm$ 0.05	0.7 $\pm$ 0.05	4 $\pm$ 0.1	4 $\pm$ 0.1	2 $\pm$ 0.1	0.2 $\pm$ 0.05

(in mm)

### Minimum Quantity

- MM5831-2700RJ4: 180 mm dia. reel/4000 pcs.  
 MM5831-2700RK15: 330 mm dia. reel/15000 pcs.

# Microwave Coaxial Board to Board Connectors

## Microwave Coaxial Board to Board Connectors KSC Type

### Features

1. The microwave coaxial Board to Board connector is small, thin and suitable for internal wiring of cellular phone and small wireless equipment such as wearable equipment.
2. Receptacle size 1.3x1.2 (LxW), Occupation area 1.56mm<sup>2</sup>, Plug receptacle size 1.4x1.2 (LxW), Occupation area 1.68mm<sup>2</sup>
3. Mating height is 0.6mm max., which is worlds lowest profile level, with plug receptacle and receptacle.
4. V.S.W.R. 1.4 max. (DC to 6GHz)
5. This has good lock feeling when plug receptacle and receptacle are mated.
6. This connector mates with MM6829-2700.

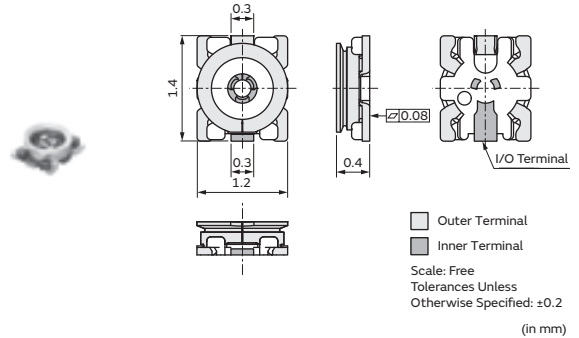

### Applications

Cellular phone, Wearable equipment and other wireless equipment

Part Number	Center Contact Resistance (mΩ max.)	Withstanding Voltage (Vrms)	Insulation Resistance (MΩ)	Durability (Cycle)	Nominal Frequency Range (GHz)	VSWR (dB max.)
<b>MM6831-2700</b>	35	200	500	30	to 6	1.3 (DC to 3GHz) 1.4 (3GHz to 6GHz)

Nominal Impedance: 50Ω  
 Rated Voltage: 30Vrms  
 Temperature Rating: -40 to 85°C

### Specification (Insertion Loss & VSWR)

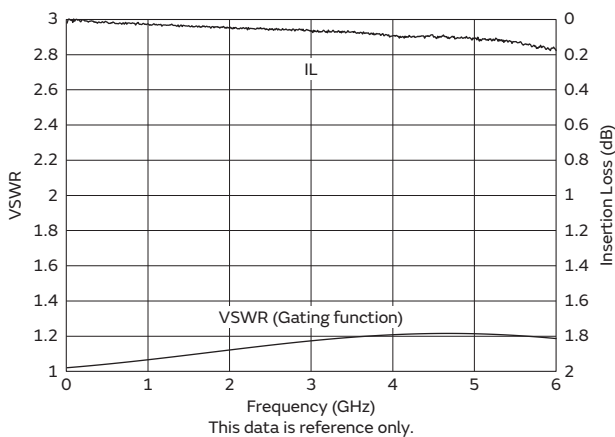

Measurement system: Refer to electrical performance measurement system (p. 33)  
 Measurement condition: SMD plug + Receptacle

### Standard Pattern Dimension, Stencil Mask Pattern

- I/O pattern should be designed to be the impedance match 50 ohm.
- The material of PWB is the epoxy resin of glass fabric base. ( $\epsilon_r=4.3@1\text{GHz}$ ). Thickness is 0.4mm.
- The solder resist should be printed except for the land pattern on the PWB
- Land pattern and solder resist pattern must be followed to avoid soldering defects.

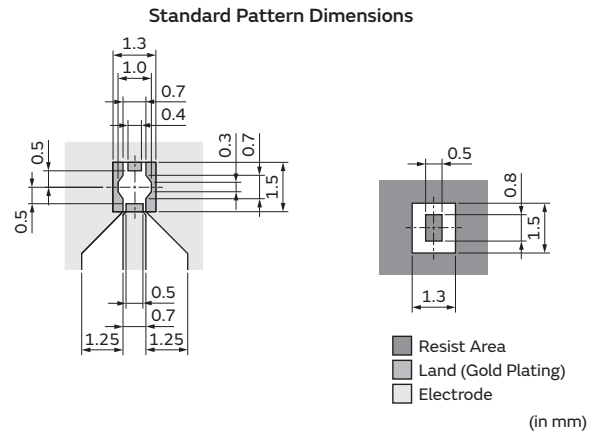

- There is the possibility to have the contact failure by flux shifting into contact point, if the excess solder is used by non-standard stencil mask pattern. Stencil mask pattern must be followed to avoid soldering defects. There is the possibility to have the contact failure by flux shifting into contact point, if the excess solder is used by non-standard stencil mask pattern. Stencil mask pattern must be followed to avoid soldering defects.

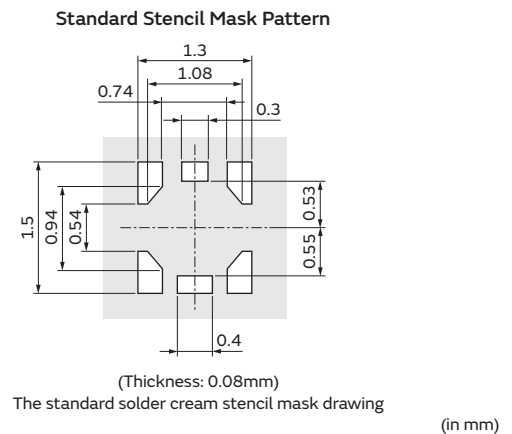

### Dimensions of Reel

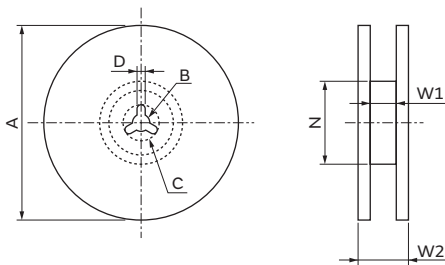

Part Number	A	B	C	D	N	W1	W2
MM6831-2700RJ5	180+0/-3	13±0.2	21±0.8	2±0.5	Dia. 60+1/-0	9±0.3	11.4±1.0
MM6831-2700RK20	330±2.0	13±0.2	21±0.8	2±0.5	Dia. 100±1.0	9.4±1.0	13.4±1.0

(in mm)

### Dimensions of Taping

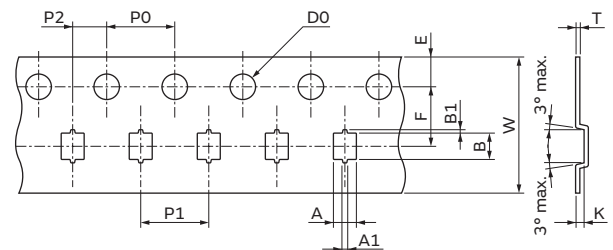

A	A1	B	B1	W	D0
1.35±0.1	0.25±0.1	1.55±0.1	0.2±0.1	8±0.2	Dia. 1.5+0.1/-0

E	F	K	P0	P1	P2	T
1.75±0.1	3.5±0.1	0.5±0.05	4±0.1	4±0.1	2±0.1	0.2±0.1

(in mm)

### Minimum Quantity

MM6831-2700RJ5: 180 mm dia. reel/5000 pcs.  
 MM6831-2700RK20: 330 mm dia. reel/20000 pcs.

# Microwave Coaxial Board to Board Connectors

## Microwave Coaxial Board to Board Connectors LSC Type

### Features

1. The microwave coaxial Board to Board connector is small, thin and suitable for internal wiring of cellular phone and small wireless equipment such as wearable equipment.
2. Receptacle size 1.7x1.6 (LxW), Occupation area 2.72mm<sup>2</sup>, Plug receptacle size 1.9x1.7 (LxW), Occupation area 3.23mm<sup>2</sup>
3. Mating height is 0.6mm max., which is world lowest profile level, with plug receptacle and receptacle.
4. V.S.W.R. 1.4 max. (DC to 6GHz)
5. This has good lock feeling when plug receptacle and receptacle are mated.
6. This connector mate with MM7829-2700.

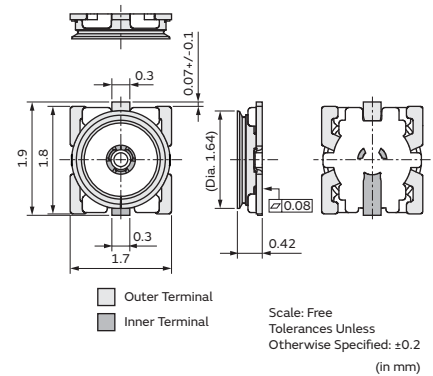

### Applications

Cellular phone, Wearable equipment and other wireless equipment

Part Number	Center Contact Resistance (mΩ max.)	Withstanding Voltage (Vrms)	Insulation Resistance (MΩ)	Durability (Cycle)	Nominal Frequency Range (GHz)	VSWR (dB max.)
<b>MM7831-2700</b>	35	200	500	30	to 6	1.3 (DC to 3GHz) 1.4 (3GHz to 6GHz)

Nominal Impedance: 50Ω  
 Rated Voltage: 30Vrms  
 Temperature Rating: -40 to 85°C

### Specification (Insertion Loss & VSWR)

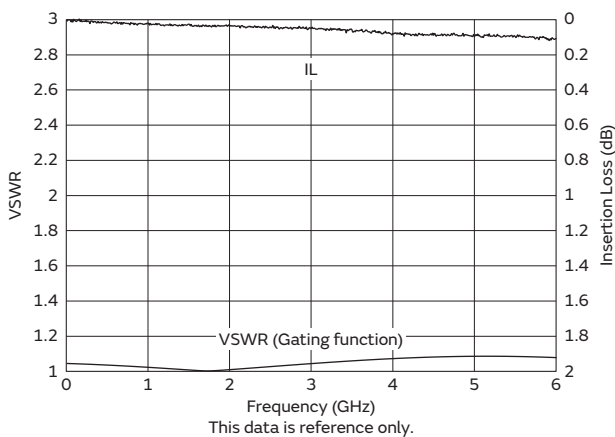

This data is reference only.

Measurement system: Refer to electrical performance measurement system (p. 33)  
 Measurement condition: SMD plug + Receptacle

### Standard Pattern Dimension, Stencil Mask Pattern

- I/O pattern should be designed to be the impedance match 50 ohm.
- The material of PWB is the epoxy resin of glass fabric base. ( $\epsilon_r=4.3@1\text{GHz}$ ). Thickness is 0.4mm.
- The solder resist should be printed except for the land pattern on the PWB
- Land pattern and solder resist pattern must be followed to avoid soldering defects.

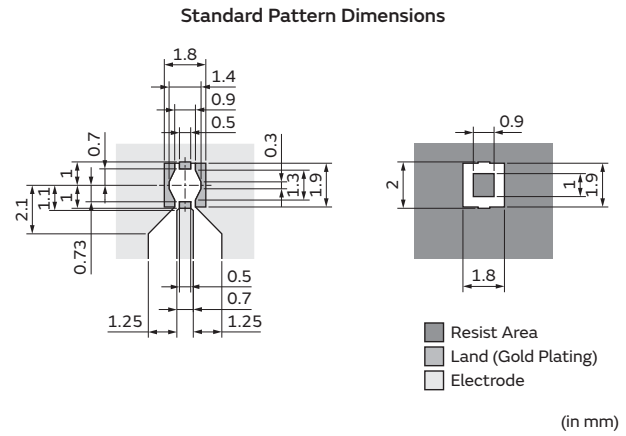

- There is the possibility to have the contact failure by flux shifting into contact point, if the excess solder is used by non-standard stencil mask pattern. Stencil mask pattern must be followed to avoid soldering defects.

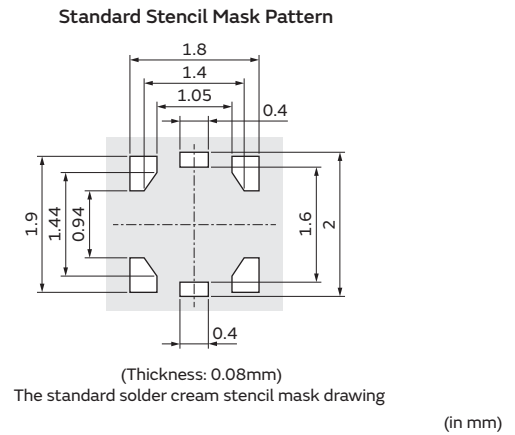

### Dimensions of Reel

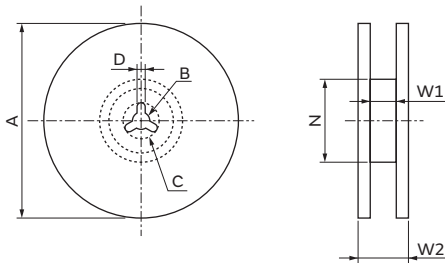

Part Number	A	B	C	D	N	W1	W2
MM7831-2700RJ5	180+0/-3	13±0.5	21±0.8	2±0.5	Dia. 60+1/-0	9±0.3	11.4±1.0
MM7831-2700RK20	330±2.0	13±0.5	21±0.8	2±0.5	Dia. 100±1.0	9.4±1.0	13.4±1.0

(in mm)

### Dimensions of Taping

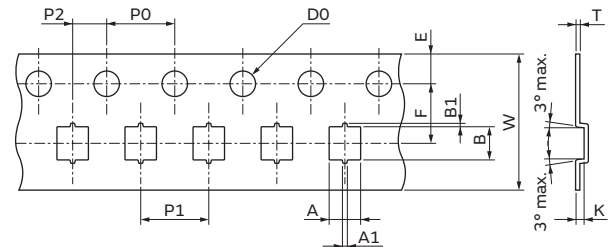

A	A1	B	B1	W	D0	
1.85±0.1	0.25±0.1	1.95±0.1	0.2±0.1	8±0.2	Dia. 1.5+0.1/-0	
E	F	K	P0	P1	P2	T
1.75±0.1	3.5±0.1	0.5±0.05	4±0.1	4±0.1	2±0.1	0.2±0.1

(in mm)

### Minimum Quantity

- MM7831-2700RJ5: 180 mm dia. reel/5000 pcs.
- MM7831-2700RK20: 330 mm dia. reel/20000 pcs.

## Notice (Design)

### Microwave Coaxial Connectors, Microwave Coaxial Board to Board Connectors

Connector performance is influenced by GND among inner layers of substrate.

We recommend making space more than 0.4mm between connectors and GND.

And please avoid placing signal lines and power lines under connectors to prevent interference with signals which pass connectors.

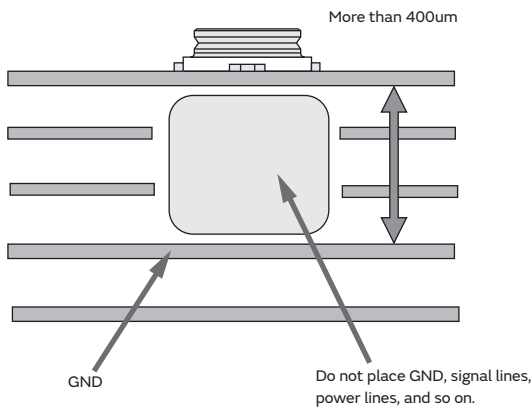
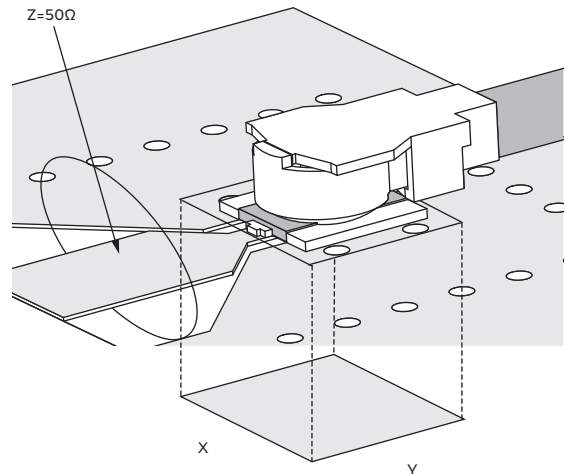

Part Number	X	Y
MM5829-2700	2.2	2.4
MM5831-2700	2.4	2.2
MM6829-2700	1.3	1.4
MM6831-2700	1.3	1.5
MM7829-2700	1.7	1.8
MM7831-2700	1.8	2.0

### Microwave Coaxial Connectors with Switch

Connector performance is influenced by GND among inner layers of substrate.

We recommend making space more than 0.4mm between connectors and GND.

And please avoid placing signal lines and power lines under connectors to prevent interference with signals which pass connectors.

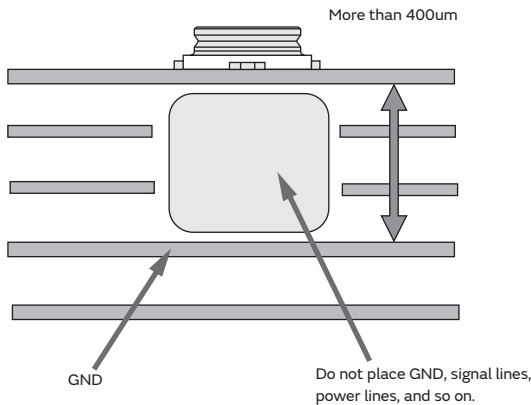
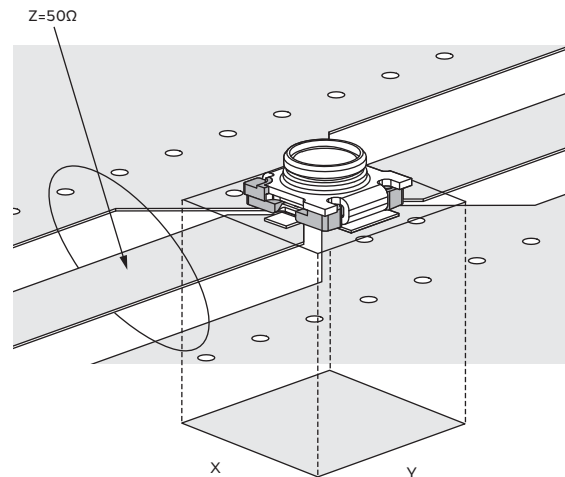

Part Number	X	Y
MM8430-2610	4.0	4.1
MM8130-2600	2.8	2.9
MM8030-2610	2.3	2.3
MM8930-2600	1.7	1.8
MM8930-2620	1.7	1.8
MM8830-2600	1.3	1.5



## Notice (Engagement/Disengagement)

### Microwave Coaxial Connectors with Cable

When you mate/unmate connectors and cables, please use specialized engage/disengagement jig.

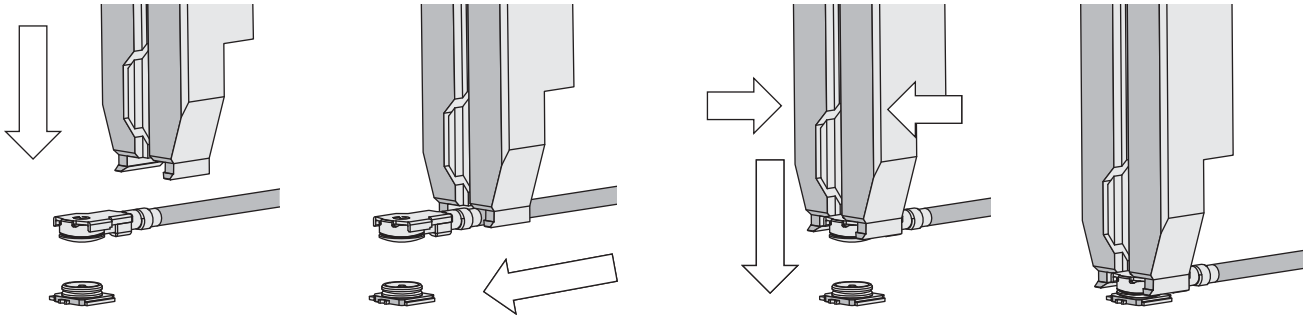

Please mate to cable plugs and connectors when centering them and keeping parallel state.

Mating is completed when you feel the click.

Please confirm if mating height is in specification after mating is completed.

Please do not stress more than 30N when mating cable plugs and connectors.

### Microwave Coaxial Board to Board Connectors

Please mate to connectors when centering them and keeping parallel state.

Mating is completed when you feel the click.

Please confirm if mating height is in specification after mating is completed.

Please do not stress more than 30N when mating connectors.

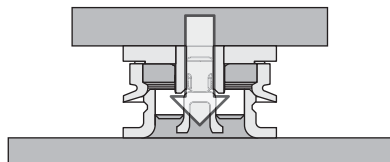

## Type of Probes

We have lineup of measurement probes that are designed for Murata connectors.  
Please use Murata probes for Murata connectors.

### Manual probe without cable

---



This is used for evaluation in lab. Measurement cable is able to be attached with this probe. This probe stands itself after mating is completed, because it has claw at contact point with connectors. Any stress to probe via cable after engagement may cause that probe come off, connectors get damage, or electrode peel off.

### Auto probe without floating mechanism

---



This probe is used for inspection in mass production process. Probes are built in measurement fixture, and pressed at connectors. This probe will not damage connectors because it doesn't have locking function by claw. Measurement fixture needs to have floating mechanism since the probe doesn't have floating mechanism itself. Measurement cable is able to be attached with this probe.

### Auto probe (tension free type)

---



This probe is used for inspection in mass production process. It has same function as Auto probe with floating mechanism. This probe is not affected by cable tension because of its special construction. The probe makes conversion cable easy to be handled.

### Manual probe with cable

---



This is used for evaluation in lab. Measurement cable is assembled with probes. This probe stands itself after mating is completed, because it has claw at contact point with connectors. Any stress to probe via cable after engagement may cause that probe come off, connectors get damage, or electrode peel off.

### Auto probe with floating mechanism

---



This probe is used for inspection in mass production process. Probes are built in measurement fixture, and pressed at connectors. This probe will not damage connectors because it doesn't have locking function by claw. Measurement fixture doesn't need to have floating mechanism since the probe has floating mechanism itself.

### Calibration adapter

---



This adapter is used for calibrating probes. This has SMA connector on one side and Murata connector shape on the other side. It can connect cable from network analyzer and tip of probe.

## Electrical Performance Measurement System (Insertion Loss, VSWR)

### 1. Measurement method of cables

#### (1) Calibration

Use CAL KIT to do SOLT calibration of measurement instrument.

Use through PWB to do through calibration.

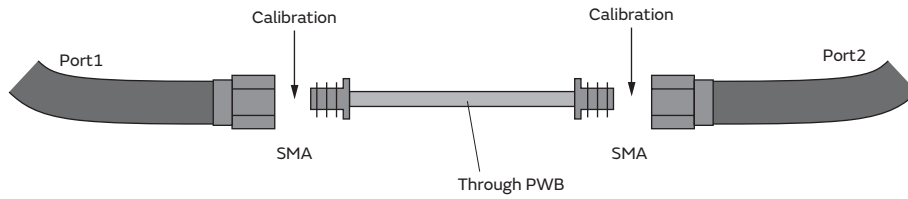

#### (2) Measurement

##### [1] Insertion Loss

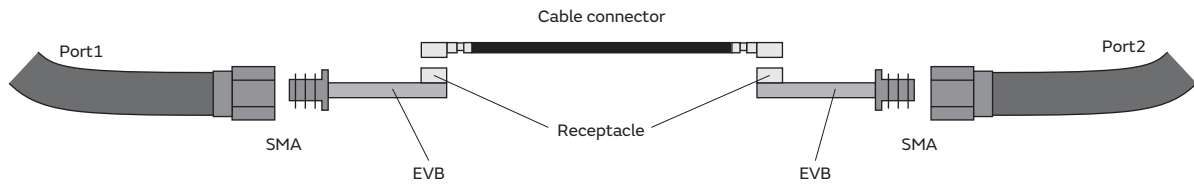

##### [2] VSWR

Use Gating function of network analyzer to measure connector part.

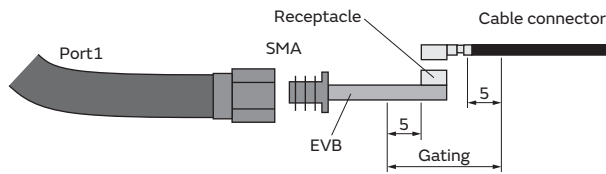

### 2. Measurement method of board to board connectors

#### (1) Calibration

Use CAL KIT to do SOLT calibration of measurement instrument.

Use through PWB to do through calibration.

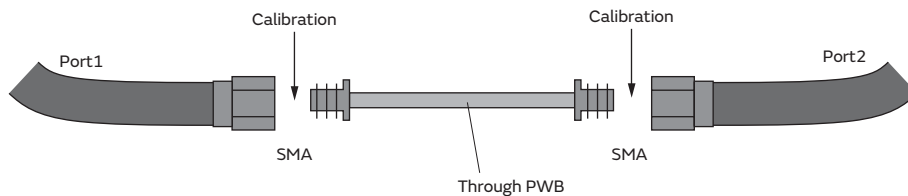

#### (2) Measurement

##### [1] Insertion Loss

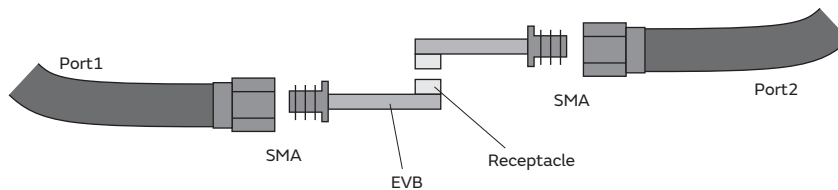

##### [2] VSWR

Use Gating function of network analyzer to measure connector part.

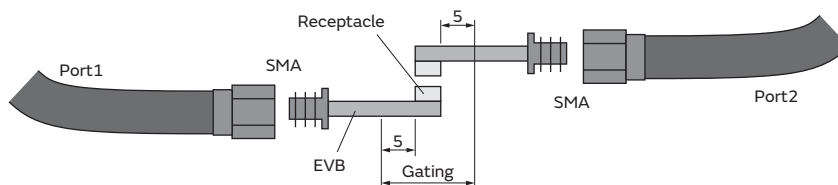

## Mechanical Performance Measurement System (Engagement/Disengagement Force)

### 1. Engagement/Disengagement force

#### [1] Engagement force

To measure require force for complete engagement connectors and receptacles.

Measuring engagement maximum force by pushing down of push-pull gauge with engagement/disengagement tool on the tip.

#### [2] Disengagement force

To measure require force for complete disengagement connectors and receptacles from mated state.

Measuring disengagement maximum force by pulling up of push-pull gauge with engagement/disengagement tool on the tip.

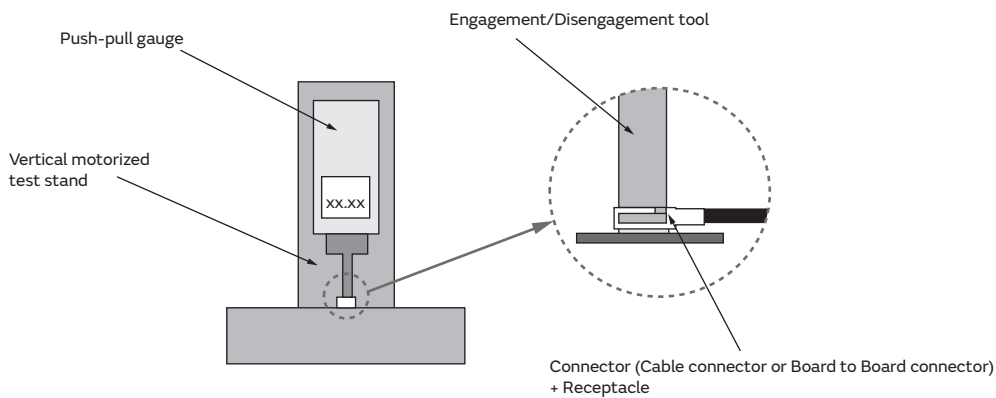

## Notice

### Notice (Storage and Operating Condition)

#### 1. Environment Conditions

- (1) This product is designed for use in electrical equipment in the environment (temperature, humidity, atmospheric pressure, etc.) specified in this approval drawing. It may not be used in the following environments or under the following conditions:
- (a) Ambient air containing corrosive gas (Cl<sub>2</sub>, H<sub>2</sub>S, NH<sub>3</sub>, SO<sub>x</sub>, NO<sub>x</sub> etc.).
  - (b) Ambient air containing volatile or combustible gas.
  - (c) In liquid (water, oil, chemical solution, organic solvents, etc.).
  - (d) In environments with a high concentration of airborne particles.
  - (e) In direct sunlight.
  - (f) Dusty conditions.
  - (g) In freezing.
  - (h) Other environments similar to the above conditions.
- (2) Contact the manufacturer before using the product in any of the above environments or under any of the above conditions.

#### 2. Storage

Store in manufacturer's package or tightly re-closed box with the following conditions. Use this product within 6 months after receipt. Check the terminal solderability before use if the product has been stored for more than 6 months.

Temperature: -10 to +40 degree C

Humidity: 15 to 85% RH

### Notice (Soldering and Mounting)

#### 1. Reflow soldering

Soldering must be carried out without exceeding the allowable soldering temperature and time shown within the shaded area of Figure "Allowable Temperature and Time of Reflow Soldering".

In case the soldering is repeated, the maximum time in Figure "Allowable Temperature and Time of Reflow Soldering" should be accumulated time. The standard soldering conditions are shown in Figure "Reflow Soldering Standard Conditions".

Follow standard pattern dimensions.

- 2. Please contact us before use if concerning other soldering conditions.
- 3. In soldering, do not apply excessive mechanical force to terminals or leads greater than specified in the drawing.
- 4. Please note the following in case of soldering terminals or leads of the product.
  - (1) Use Rosin based flux, but not with strong acid flux (Chlorine content should be less than 0.20wt%).
  - (2) Flux should be cleaned thoroughly.
- 5. Please mount this product at the position so that stress by wrap and/or bend of the PCB may not apply to it.
- 6. Please dry out this product immediately after soldering and cleaning.
- 7. Please avoid the cleaning of this product for Microwave Coaxial Connector with Switch.

Allowable Temperature and Time of Reflow Soldering

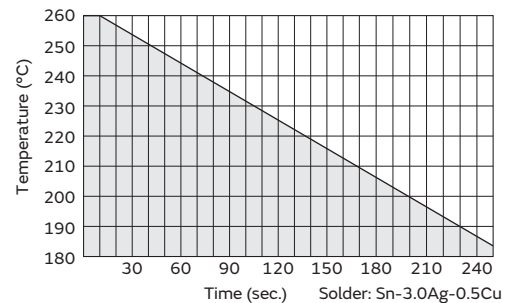

Reflow Soldering Standard Conditions

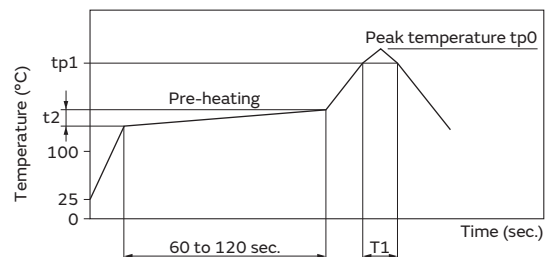

	tp0 (°C)	tp1 (°C)	T1 (sec.)	t2 (°C)
Standard soldering condition	240+0/-5	220	30 to 60	150 to 180
Resistance to soldering heat condition	260+5/-0	240	30max.	150 to 180

Measuring point of temperature: In-Out Terminals of the Device  
 Reflow Soldering: Both Convection and Infrared Rays  
 : Hot Air  
 : Hot Plate

# Global Locations

For details please visit [www.murata.com](http://www.murata.com)



## ⚠ Note

### 1 Export Control

*For customers outside Japan:*

No Murata products should be used or sold, through any channels, for use in the design, development, production, utilization, maintenance or operation of, or otherwise contribution to (1) any weapons (Weapons of Mass Destruction [nuclear, chemical or biological weapons or missiles] or conventional weapons) or (2) goods or systems specially designed or intended for military end-use or utilization by military end-users.

*For customers in Japan:*

For products which are controlled items subject to the "Foreign Exchange and Foreign Trade Law" of Japan, the export license specified by the law is required for export.

2 Please contact our sales representatives or product engineers before using the products in this catalog for the applications listed below, which require especially high reliability for the prevention of defects which might directly damage a third party's life, body or property, or when one of our products is intended for use in applications other than those specified in this catalog.

- ① Aircraft equipment
- ② Aerospace equipment
- ③ Undersea equipment
- ④ Power plant equipment
- ⑤ Medical equipment
- ⑥ Transportation equipment (vehicles, trains, ships, etc.)
- ⑦ Traffic signal equipment
- ⑧ Disaster prevention / crime prevention equipment
- ⑨ Data-processing equipment
- ⑩ Application of similar complexity and/or reliability requirements to the applications listed above

3 Product specifications in this catalog are as of June 2018. They are subject to change or our products in it may be discontinued without advance notice. Please check with our sales representatives or product engineers before ordering. If there are any questions, please contact our sales representatives or product engineers.

4 Please read rating and ⚠CAUTION (for storage, operating, rating, soldering, mounting and handling) in this catalog to prevent smoking and/or burning, etc.

5 This catalog has only typical specifications. Therefore, please approve our product specifications or transact the approval sheet for product specifications before ordering.

6 Please note that unless otherwise specified, we shall assume no responsibility whatsoever for any conflict or dispute that may occur in connection with the effect of our and/or a third party's intellectual property rights and other related rights in consideration of your use of our products and/or information described or contained in our catalogs. In this connection, no representation shall be made to the effect that any third parties are authorized to use the rights mentioned above under licenses without our consent.

7 No ozone depleting substances (ODS) under the Montreal Protocol are used in our manufacturing process.

Murata Manufacturing Co., Ltd.

[www.murata.com](http://www.murata.com)

**muRata**  
INNOVATOR IN ELECTRONICS

单击下面可查看定价，库存，交付和生命周期等信息

[>>Murata\(村田\)](#)

[>>点击查看相关商品](#)