

REVISIONS				
REV	ECO	DESCRIPTION	DATE	BY
A1	-	RELEASED DRAWING	Sep-7-2016	Ben Tommy
A2	-	Updating Drawing	Sep-14-2016	Tommy

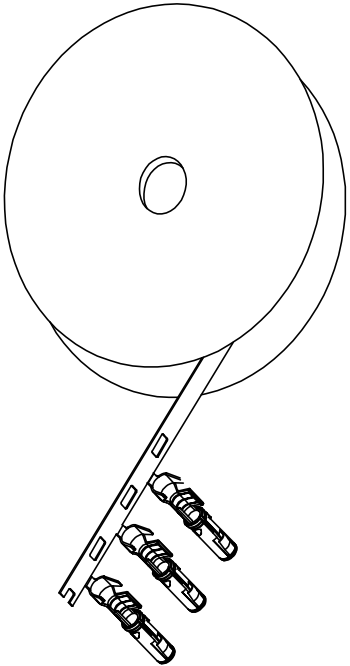

CONTACT ORIENTATION ON ROLL

NOTES : (UNLESS OTHERWISE SPECIFIED)

1. MATERIAL :
 - 1.1. CONTACT BODY : COPPER ALLOY.
 - 1.2. OUTER SPRING : STAINLESS STEEL.
2. SPECIFICATIONS :
 - 2.1 CURRENT RATING : 23A MAX.
 - 2.2 TERMINATION TYPE : CRIMPING.
 - 2.3 WIRE RANGE : 4mm².
 - 2.4 WIRE INSULATION DIA(MAX) : ϕ 4.3mm.
3. ROHS COMPLIANT.
4. ALL DIMENSIONS ARE FOR REFERENCE USE ONLY.

P/N	CONTACT PLATING(MATING AREA)
SS12A1T-10	TIN PLATING OVER NICKEL.
SS12A1F-10	GOLD FLASH PLATING OVER NICKEL.
SS12A1G10-10	10 μ " GOLD PLATING OVER NICKEL.
SS12A1G15-10	15 μ " GOLD PLATING OVER NICKEL.
SS12A1G30-10	30 μ " GOLD PLATING OVER NICKEL.

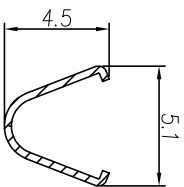

SECTION A-A

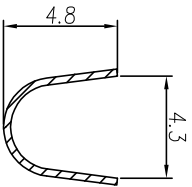

SECTION B-B

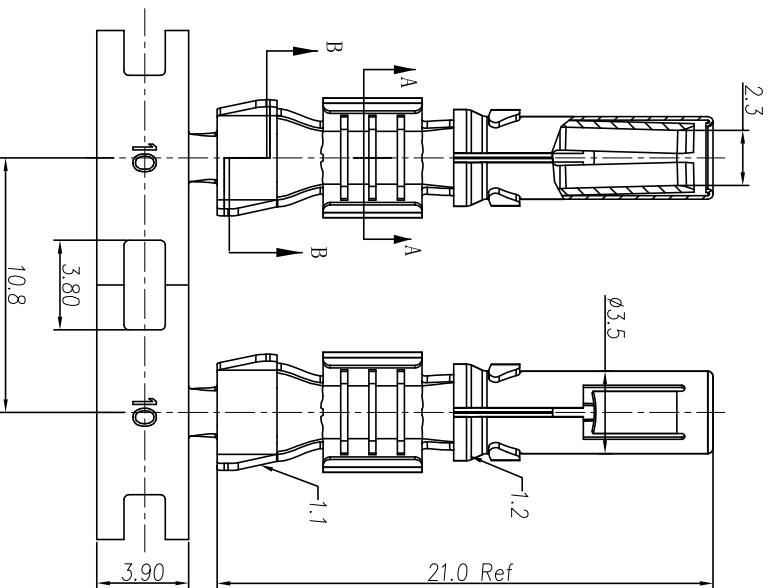

QUANTITY	PART NUMBER	DESCRIPTION	ITEM
		MATERIALS LIST	

SIGNATURES	DATE
DESIGNER: Ben	02/18/17
CHECKER: Tod	02/18/17
ENGINEER: Tommy	02/18/17
APPROVAL: Tommy	02/18/17

UNLESS OTHERWISE SPECIFIED 1) All dimensions are in millimeters. 2) Tolerances are as follows: 1 Pl. DEC 40.30 Fractions .1/16" 3 Pl. DEC 40.08 Angles .1°	PROCESS SPECIFICATIONS: NEXT ASSY:	TEST SPECIFICATIONS: SPECIFICATIONS AND PERFORMANCE DATA ARE THE PROPERTY OF AMPHENOL. ALL RIGHTS OF REPRODUCTION ARE RESERVED. ALL MANUFACTURING VARIATIONS	SCALE: NONE	SHEET 1 OF 1
--	---------------------------------------	---	-------------	--------------

Amphenol
Sine Systems - www.amphenol-sine.com
44724 Morley Drive
Clinton Township, MI 48036

ECO-MATE SOCKET CONTACT.
STAMPED, 4.0mm², 2.5mm CONTACT

单击下面可查看定价，库存，交付和生命周期等信息

[>>Amphenol\(安费诺\)](#)