

Trench gate field-stop 600 V, 5 A high speed H series IGBT

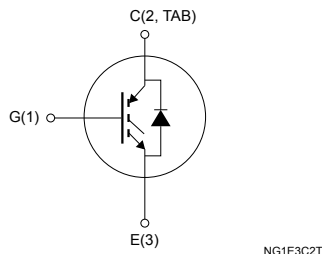
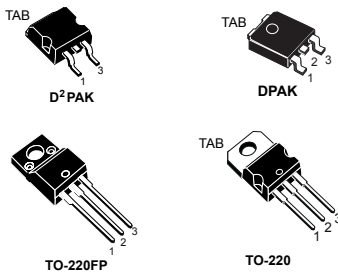

Features

- High-speed switching
- Tight parameter distribution
- Safe paralleling
- Low thermal resistance
- Short-circuit rated
- Ultrafast soft recovery antiparallel diode

Applications

- Motor control
- UPS, PFC

Description

These devices are IGBTs developed using an advanced proprietary trench gate field-stop structure. These devices are part of the H series of IGBTs, which represents an optimum compromise between conduction and switching losses to maximize the efficiency of high switching frequency converters. Furthermore, a slightly positive $V_{CE(sat)}$ temperature coefficient and very tight parameter distribution result in safer paralleling operation.

Product status link

[STGB5H60DF](#)

[STGD5H60DF](#)

[STGF5H60DF](#)

[STGP5H60DF](#)

1 Electrical ratings

Table 1. Absolute maximum ratings

Symbol	Parameter	Value			Unit
		D ² PAK, TO-220	DPAK	TO-220FP	
V _{CES}	Collector-emitter voltage (V _{GE} = 0)	600			V
I _C	Continuous collector current at T _C = 25 °C	10		10 ⁽¹⁾	A
	Continuous collector current at T _C = 100 °C	5		5 ⁽¹⁾	
I _{CP} ⁽²⁾	Pulsed collector current	20		20 ⁽¹⁾	A
V _{GE}	Gate-emitter voltage	±20			V
I _F	Continuous forward current T _C = 25 °C	10		10 ⁽¹⁾	A
	Continuous forward current at T _C = 100 °C	5		5 ⁽¹⁾	
I _{FP} ⁽²⁾	Pulsed forward current	20		20 ⁽¹⁾	A
V _{ISO}	Insulation withstand voltage (RMS) from all three leads to external heat sink (t = 1 s; T _C = 25 °C)			2500	V
P _{TOT}	Total dissipation at T _C = 25 °C	88	83	24	W
T _{STG}	Storage temperature range	-55 to 150			°C
T _J	Operating junction temperature range	-55 to 175			

1. Limited by maximum junction temperature.
2. Pulse width limited by maximum junction temperature.

Table 2. Thermal data

Symbol	Parameter	Value			Unit
		D ² PAK, TO-220	DPAK	TO-220FP	
R _{thJC}	Thermal resistance junction-case IGBT	1.7	1.8	6.2	°C/W
R _{thJC}	Thermal resistance junction-case diode	4	4.5	7	°C/W
R _{thJA}	Thermal resistance junction-ambient	62.5	100	62.5	°C/W

2 Electrical characteristics

$T_C = 25\text{ °C}$ unless otherwise specified.

Table 3. Static

Symbol	Parameter	Test conditions	Min.	Typ.	Max.	Unit
$V_{(BR)CES}$	Collector-emitter breakdown voltage	$V_{GE} = 0\text{ V}$, $I_C = 2\text{ mA}$	600			V
$V_{CE(sat)}$	Collector-emitter saturation voltage	$V_{GE} = 15\text{ V}$, $I_C = 5\text{ A}$		1.5	1.95	V
		$V_{GE} = 15\text{ V}$, $I_C = 5\text{ A}$ $T_J = 125\text{ °C}$		1.6		
		$V_{GE} = 15\text{ V}$, $I_C = 5\text{ A}$ $T_J = 175\text{ °C}$		1.7		
$V_{GE(th)}$	Gate threshold voltage	$V_{CE} = V_{GE}$, $I_C = 250\text{ }\mu\text{A}$	4.8	6.2	6.9	V
I_{CES}	Collector cut-off current	$V_{CE} = 600\text{ V}$ $V_{GE} = 0\text{ V}$			25	μA
I_{GES}	Gate-emitter leakage current	$V_{GE} = \pm 20\text{ V}$ $V_{CE} = 0\text{ V}$			± 250	nA

Table 4. Dynamic

Symbol	Parameter	Test conditions	Min.	Typ.	Max.	Unit
C_{ies}	Input capacitance	$V_{CE} = 25\text{ V}$, $f = 1\text{ MHz}$, $V_{GE} = 0\text{ V}$	-	855	-	pF
C_{oes}	Output capacitance			34		
C_{res}	Reverse transfer capacitance			19		
Q_g	Total gate charge	$V_{CC} = 480\text{ V}$, $I_C = 5\text{ A}$, $V_{GE} = 0\text{ to }15\text{ V}$	-	43	-	nC
Q_{ge}	Gate-emitter charge			17.5		
Q_{gc}	Gate-collector charge			6.5		

Table 5. Switching characteristics (inductive load)

Symbol	Parameter	Test conditions	Min.	Typ.	Max.	Unit
$t_{d(on)}$	Turn-on delay time	$V_{CE} = 400\text{ V}$, $I_C = 5\text{ A}$, $R_G = 47\text{ }\Omega$, $V_{GE} = 15\text{ V}$	-	30	-	ns
t_r	Current rise time			10.8		
$(di/dt)_{on}$	Turn-on current slope			370		
$t_{d(on)}$	Turn-on delay time	$V_{CE} = 400\text{ V}$, $I_C = 5\text{ A}$, $R_G = 47\text{ }\Omega$, $V_{GE} = 15\text{ V}$ $T_J = 175\text{ °C}$	-	28	-	ns
t_r	Current rise time			11		
$(di/dt)_{on}$	Turn-on current slope			363		

Symbol	Parameter	Test conditions	Min.	Typ.	Max.	Unit
$t_{r(Voff)}$	Off voltage rise time	$V_{CE} = 400\text{ V}$, $I_C = 5\text{ A}$, $R_G = 47\ \Omega$, $V_{GE} = 15\text{ V}$	-	29	-	ns
$t_{d(off)}$	Turn-off delay time			140		
t_f	Current fall time			95		
$t_{r(Voff)}$	Off voltage rise time	$V_{CE} = 400\text{ V}$, $I_C = 5\text{ A}$, $R_G = 47\ \Omega$, $V_{GE} = 15\text{ V}$	-	44	-	ns
$t_{d(off)}$	Turn-off delay time			146		
t_f	Current fall time	$T_J = 175\text{ }^\circ\text{C}$		134		
t_{sc}	Short-circuit withstand time	$V_{CC} \leq 360\text{ V}$, $V_{GE} = 15\text{ V}$, $R_G = 47\ \Omega$	-	5	-	μs

Table 6. Switching energy (inductive load)

Symbol	Parameter	Test conditions	Min.	Typ.	Max.	Unit
$E_{on}^{(1)}$	Turn-on switching energy	$V_{CE} = 400\text{ V}$, $I_C = 5\text{ A}$, $R_G = 47\ \Omega$, $V_{GE} = 15\text{ V}$	-	56	-	μJ
$E_{off}^{(2)}$	Turn-off switching energy			78.5		
E_{ts}	Total switching energy			134.5		
$E_{on}^{(1)}$	Turn-on switching energy	$V_{CE} = 400\text{ V}$, $I_C = 5\text{ A}$, $R_G = 47\ \Omega$, $V_{GE} = 15\text{ V}$	-	87	-	μJ
$E_{off}^{(2)}$	Turn-off switching energy			134		
E_{ts}	Total switching energy	$T_J = 175\text{ }^\circ\text{C}$		221		

1. Including the reverse recovery of the diode.
2. Including the tail of the collector current.

Table 7. Collector-emitter diode

Symbol	Parameter	Test conditions	Min.	Typ.	Max.	Unit
V_F	Forward on-voltage	$I_F = 5\text{ A}$	-	2.1	-	V
		$I_F = 5\text{ A}$, $T_J = 175\text{ }^\circ\text{C}$		1.65		
t_{rr}	Reverse recovery time	$V_{CC} = 400\text{ V}$; $I_F = 5\text{ A}$; $di_F/dt = 100\text{ A}/\mu\text{s}$	-	134.5	-	ns
Q_{rr}	Reverse recovery charge			48		nC
I_{rrm}	Reverse recovery current			1.38		A
t_{rr}	Reverse recovery time	$V_{CC} = 400\text{ V}$; $I_F = 5\text{ A}$; $di_F/dt = 100\text{ A}/\mu\text{s}$	-	157	-	ns
Q_{rr}	Reverse recovery charge			165		nC
I_{rrm}	Reverse recovery current	$T_J = 175\text{ }^\circ\text{C}$		2.4		A

2.1 Electrical characteristics curves

Figure 1. Power dissipation vs case temperature for D²PAK and TO-220

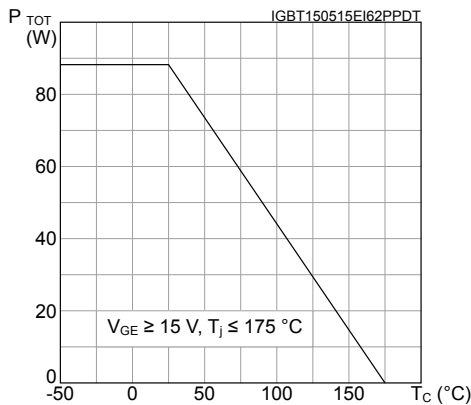

Figure 2. Collector current vs case temperature for D²PAK, DPAK and TO-220

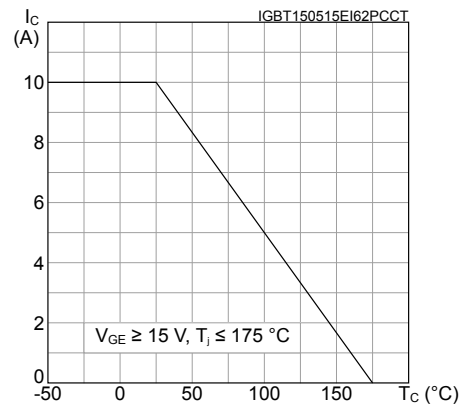

Figure 3. Power dissipation vs case temperature for DPAK

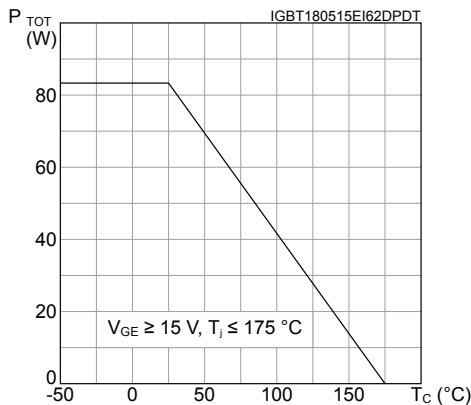

Figure 4. Collector current vs case temperature for DPAK

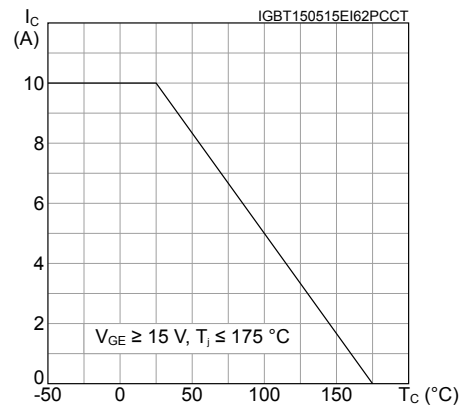

Figure 5. Power dissipation vs case temperature for TO-220FP

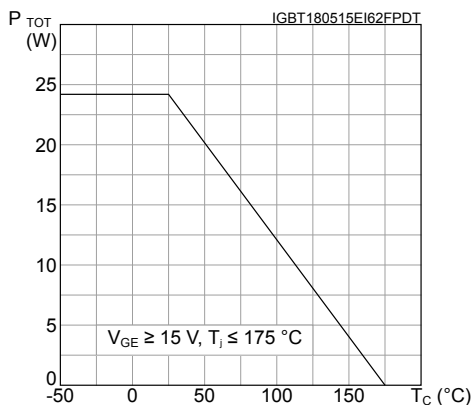

Figure 6. Collector current vs case temperature for TO-220FP

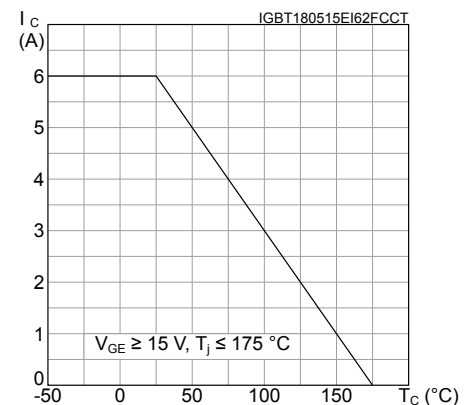

Figure 7. Output characteristics ($T_J = 25^\circ\text{C}$)

Figure 8. Output characteristics ($T_J = 175^\circ\text{C}$)

Figure 9. $V_{CE(sat)}$ vs junction temperature

Figure 10. $V_{CE(sat)}$ vs collector current

Figure 11. Collector current vs switching frequency for D²PAK, DPAK and TO-220

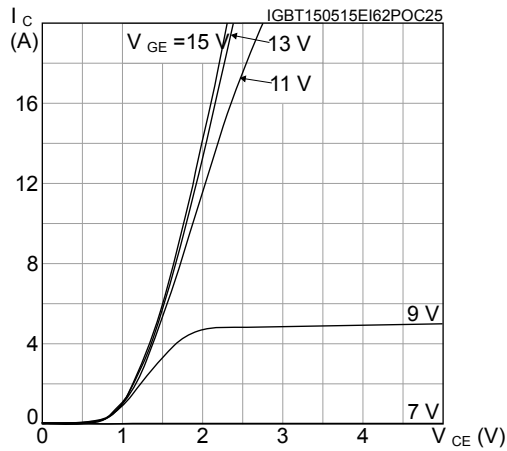
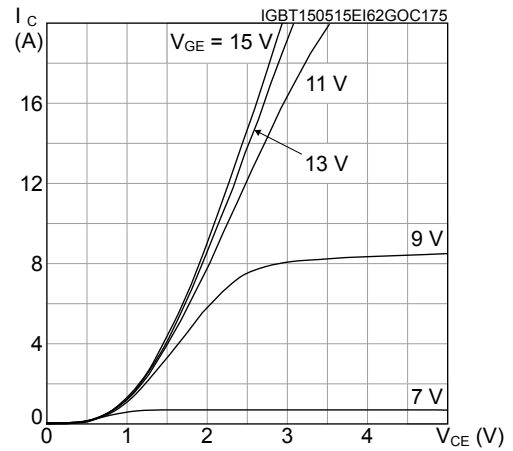
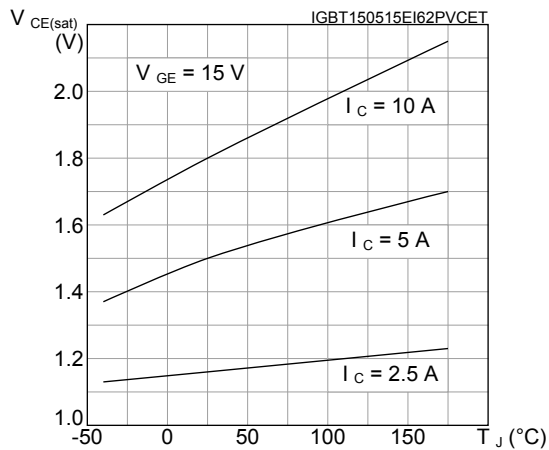
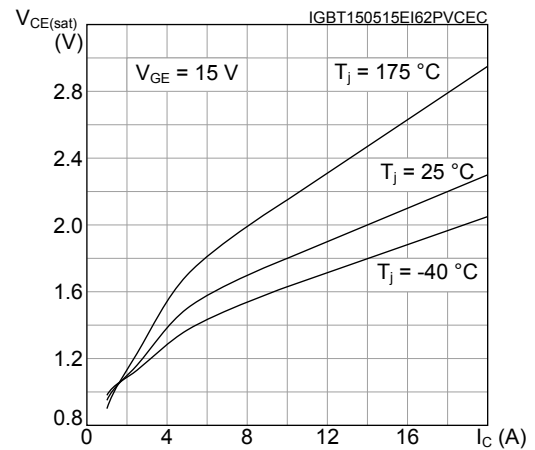
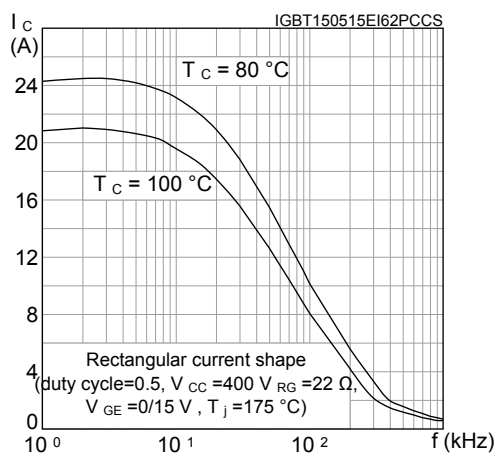
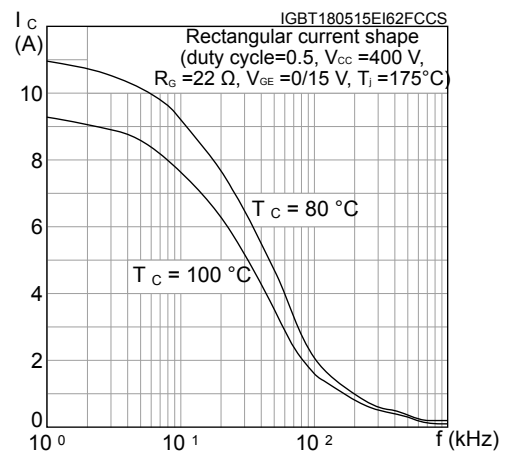
Figure 12. Collector current vs switching frequency for TO-220FP

Figure 13. Forward bias safe operating area for D²PAK, DPAK and TO-220

Figure 14. Forward bias safe operating area for TO-220FP

Figure 15. Transfer characteristics

Figure 16. Diode V_F vs forward current

Figure 17. Normalized V_{GE(th)} vs junction temperature

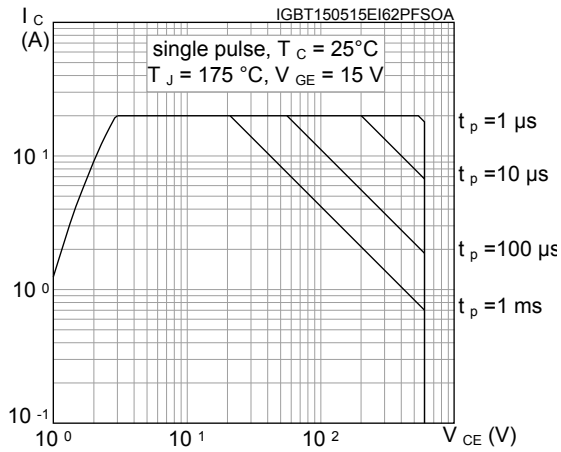
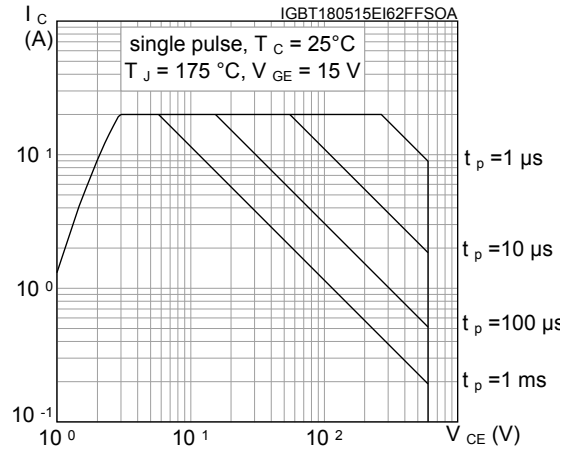
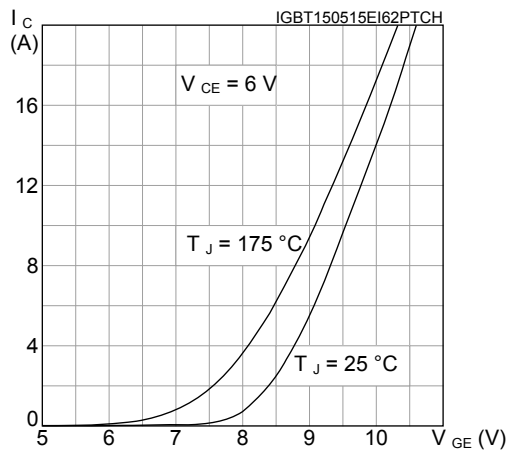
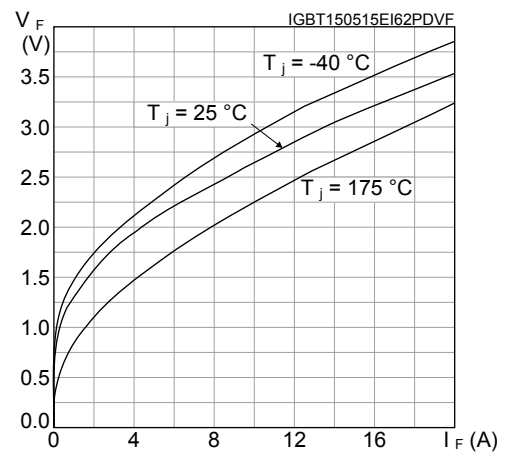
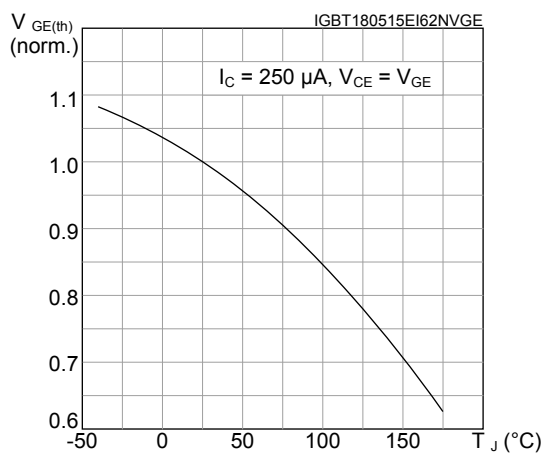
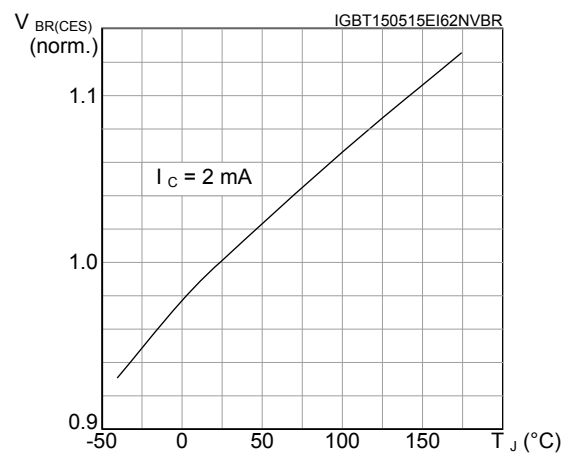
Figure 18. Normalized V_{BR(CES)} vs junction temperature

Figure 19. Capacitance variation

Figure 20. Gate charge vs. gate-emitter voltage

Figure 21. Switching energy vs collector current

Figure 22. Switching energy vs gate resistance

Figure 23. Switching energy vs temperature

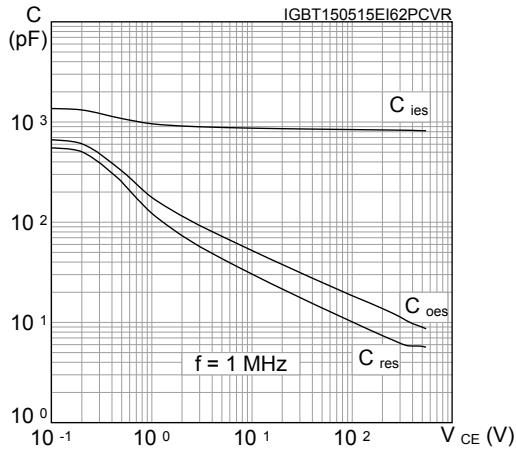
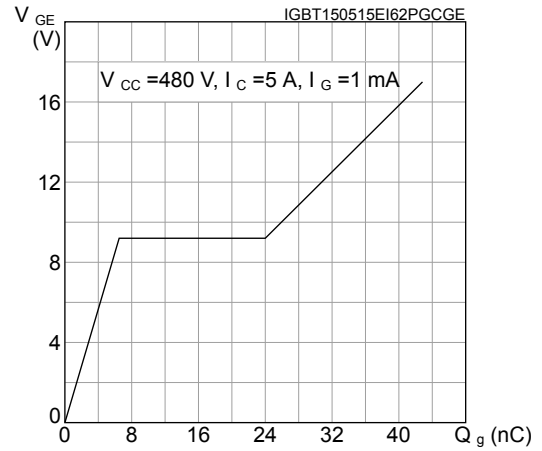
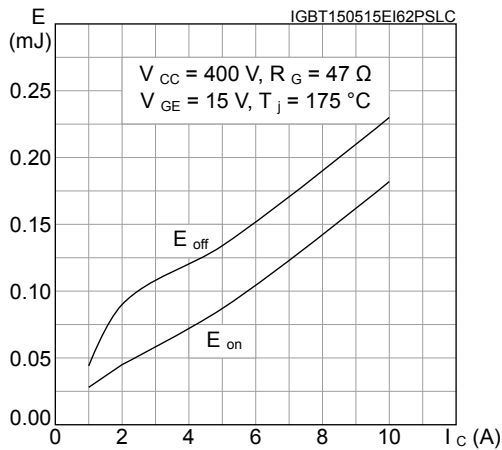
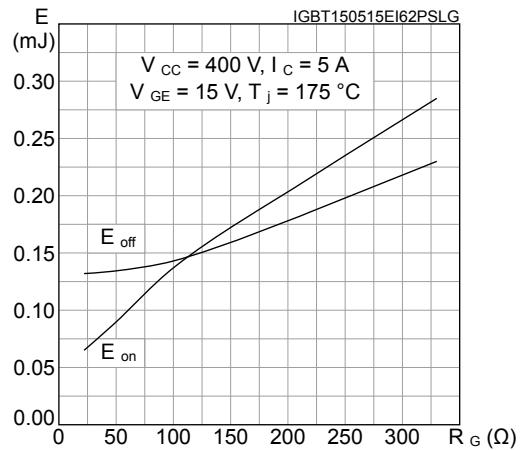
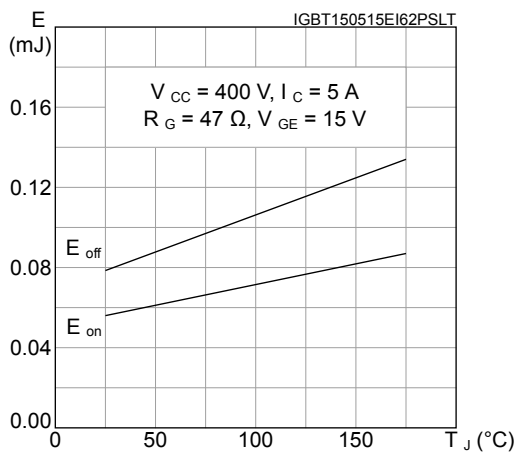
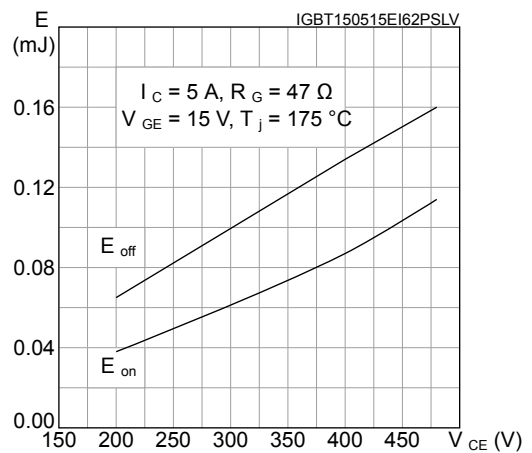
Figure 24. Switching energy vs collector-emitter voltage

Figure 25. Short circuit time and current vs V_{GE}

Figure 26. Switching times vs collector current

Figure 27. Switching times vs gate resistance

Figure 28. Reverse recovery current vs diode current slope

Figure 29. Reverse recovery time vs diode current slope

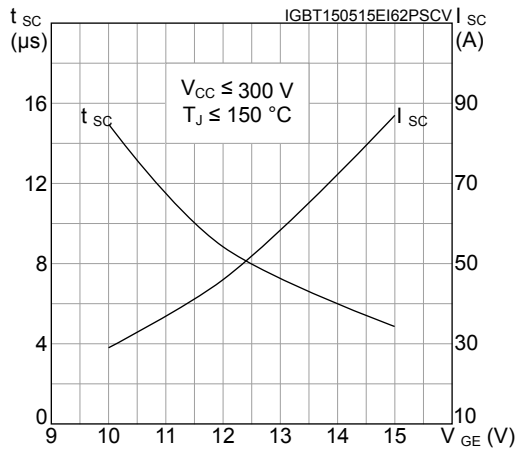
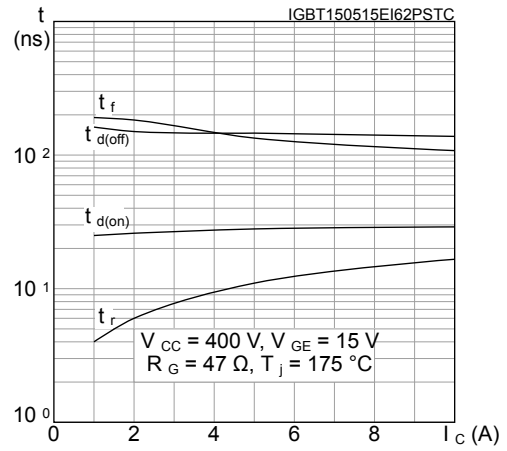
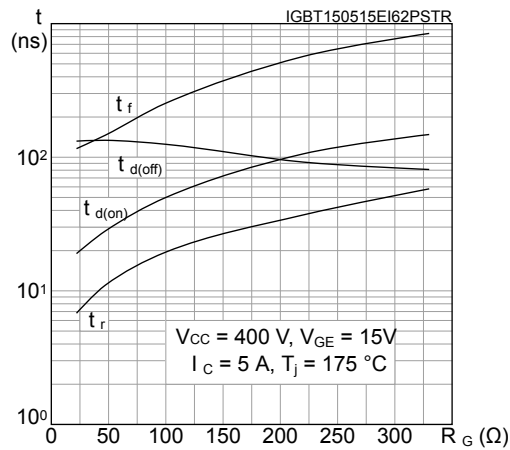
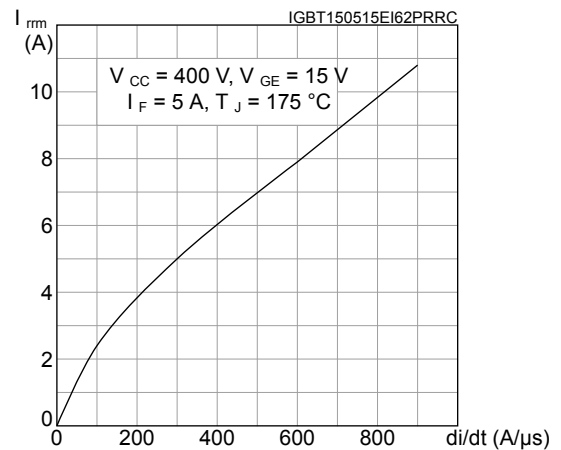
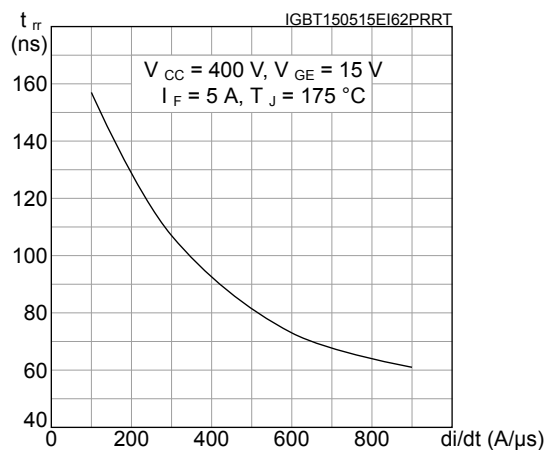
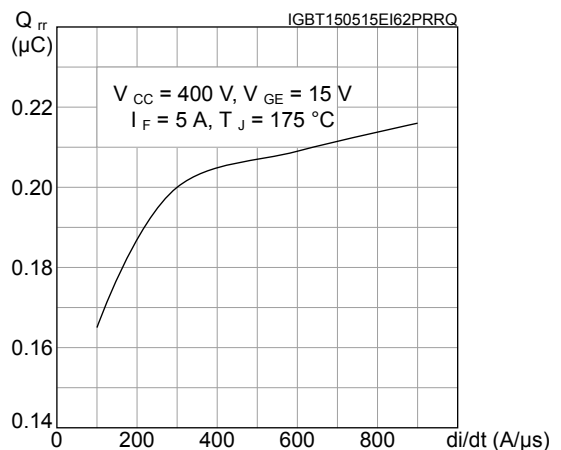
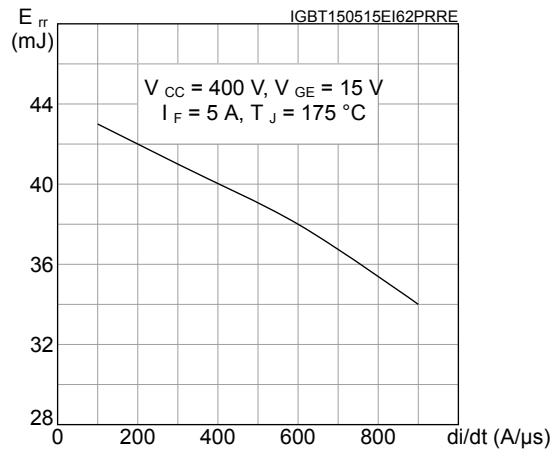
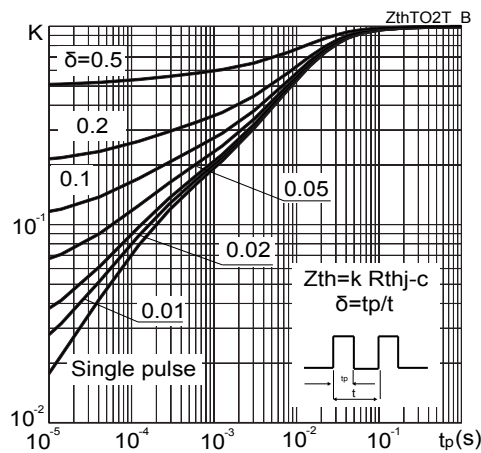
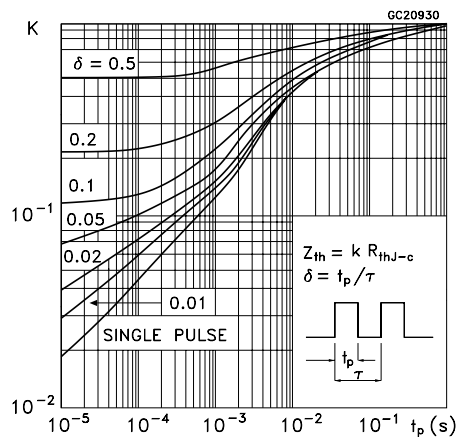
Figure 30. Reverse recovery charge vs diode current slope

Figure 31. Reverse recovery energy vs diode current slope

Figure 32. Thermal impedance for D²PAK, DPAK and TO-220 IGBT

Figure 33. Thermal impedance for D²PAK, DPAK and TO-220 diode

3 Test circuits

Figure 34. Test circuit for inductive load switching

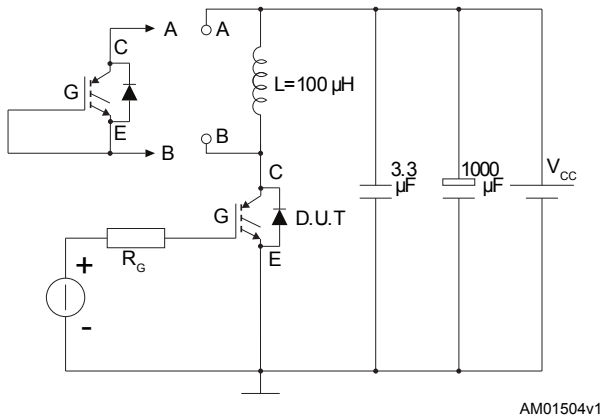

Figure 35. Gate charge test circuit

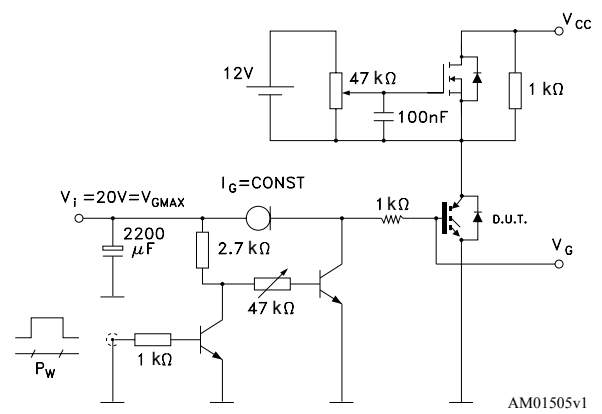

Figure 36. Switching waveform

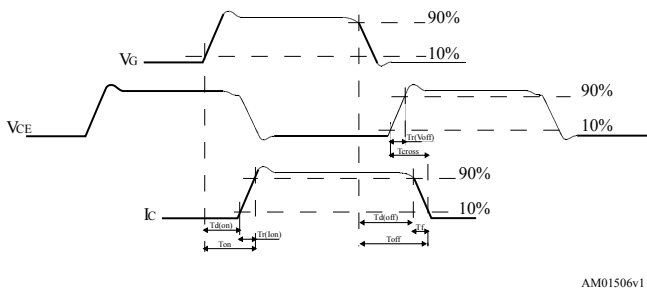
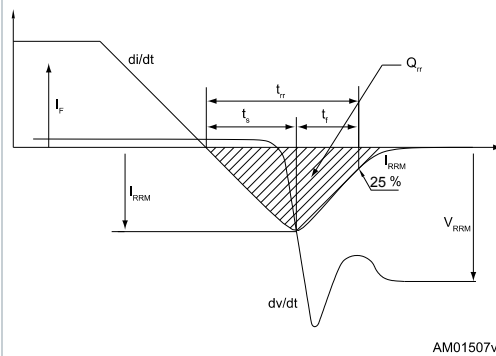

Figure 37. Diode reverse recovery waveform



4 Package information

In order to meet environmental requirements, ST offers these devices in different grades of ECOPACK® packages, depending on their level of environmental compliance. ECOPACK® specifications, grade definitions and product status are available at: www.st.com. ECOPACK® is an ST trademark.

4.1 D²PAK (TO-263) type A package information

Figure 38. D²PAK (TO-263) type A package outline

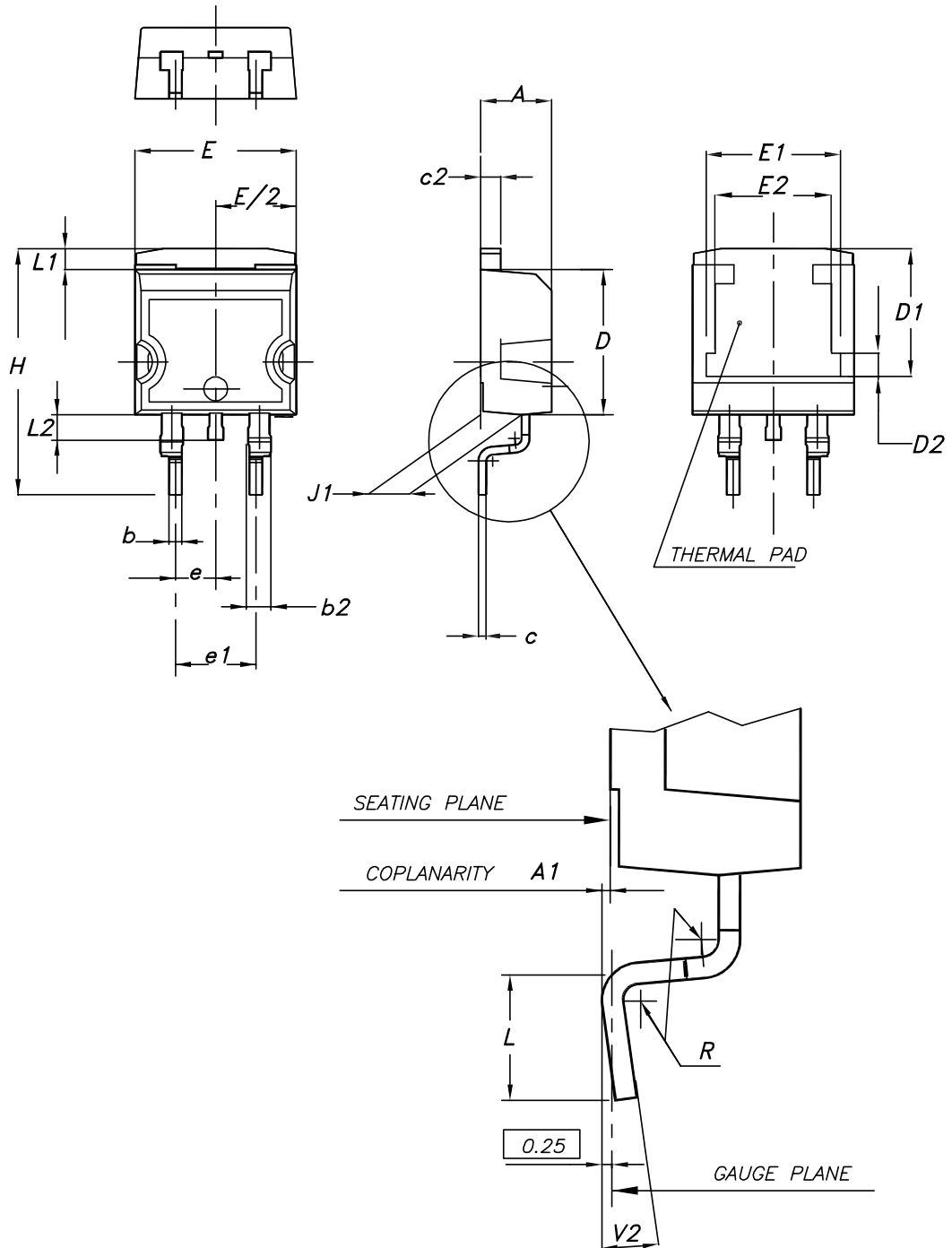

0079457_25

Table 8. D²PAK (TO-263) type A package mechanical data

Dim.	mm		
	Min.	Typ.	Max.
A	4.40		4.60
A1	0.03		0.23
b	0.70		0.93
b2	1.14		1.70
c	0.45		0.60
c2	1.23		1.36
D	8.95		9.35
D1	7.50	7.75	8.00
D2	1.10	1.30	1.50
E	10.00		10.40
E1	8.30	8.50	8.70
E2	6.85	7.05	7.25
e		2.54	
e1	4.88		5.28
H	15.00		15.85
J1	2.49		2.69
L	2.29		2.79
L1	1.27		1.40
L2	1.30		1.75
R		0.40	
V2	0°		8°

Figure 39. D²PAK (TO-263) recommended footprint (dimensions are in mm)

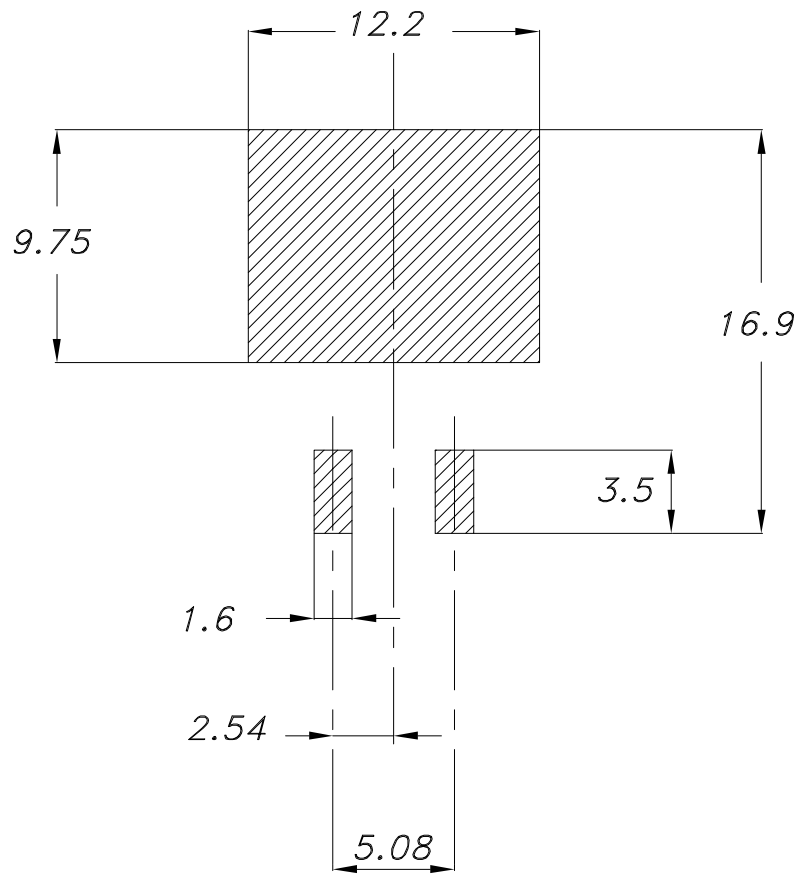

Footprint

4.2 D²PAK packing information

Figure 40. D²PAK tape outline

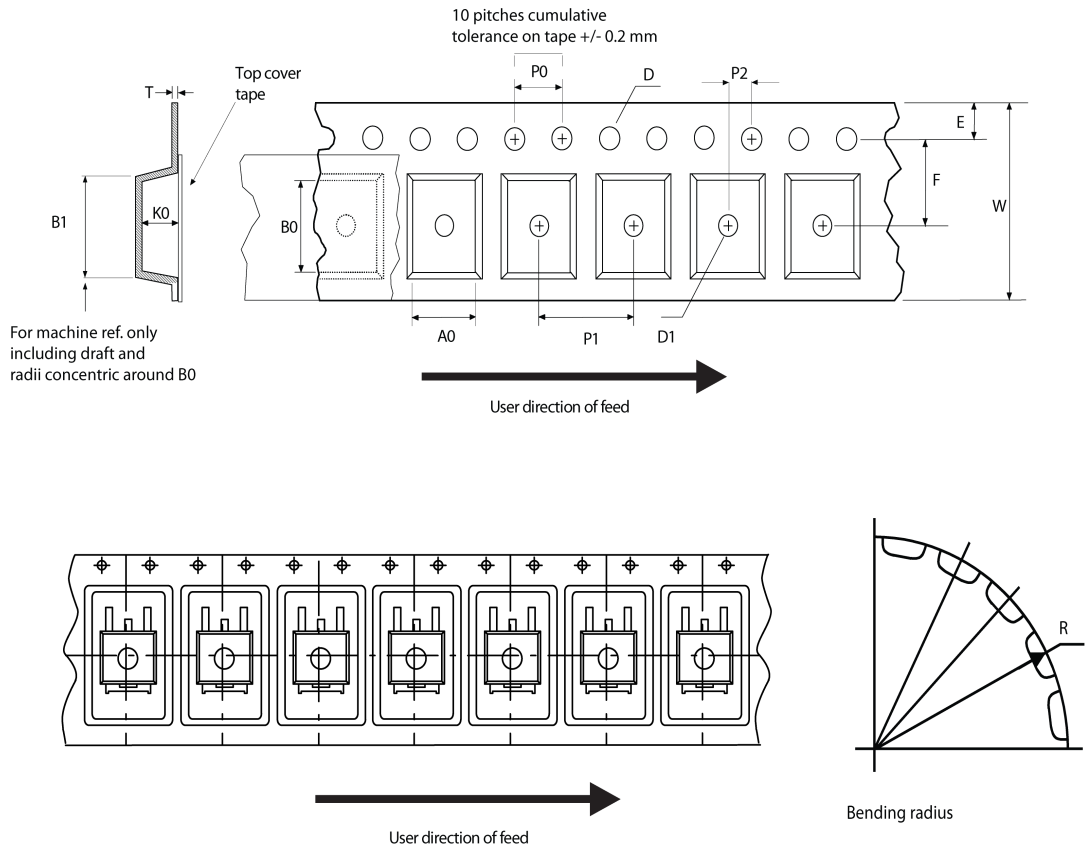

AM08852v1

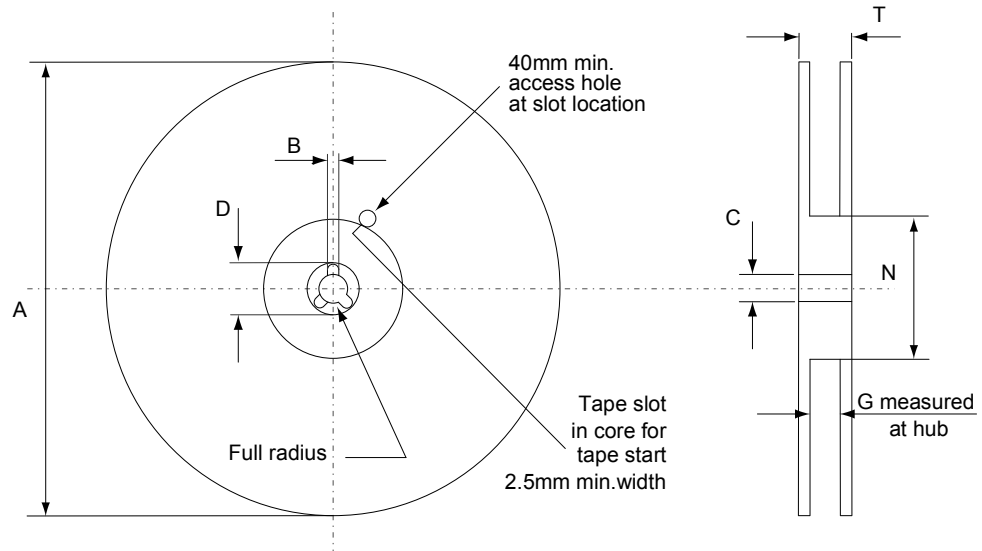
Figure 41. D²PAK reel outline

AM06038v1

Table 9. D²PAK tape and reel mechanical data

Tape			Reel		
Dim.	mm		Dim.	mm	
	Min.	Max.		Min.	Max.
A0	10.5	10.7	A		330
B0	15.7	15.9	B	1.5	
D	1.5	1.6	C	12.8	13.2
D1	1.59	1.61	D	20.2	
E	1.65	1.85	G	24.4	26.4
F	11.4	11.6	N	100	
K0	4.8	5.0	T		30.4
P0	3.9	4.1	Base quantity		
P1	11.9	12.1			
P2	1.9	2.1	Bulk quantity		
R	50				
T	0.25	0.35			
W	23.7	24.3			

4.3 DPAK (TO-252) type A2 package information

Figure 42. DPAK (TO-252) type A2 package outline

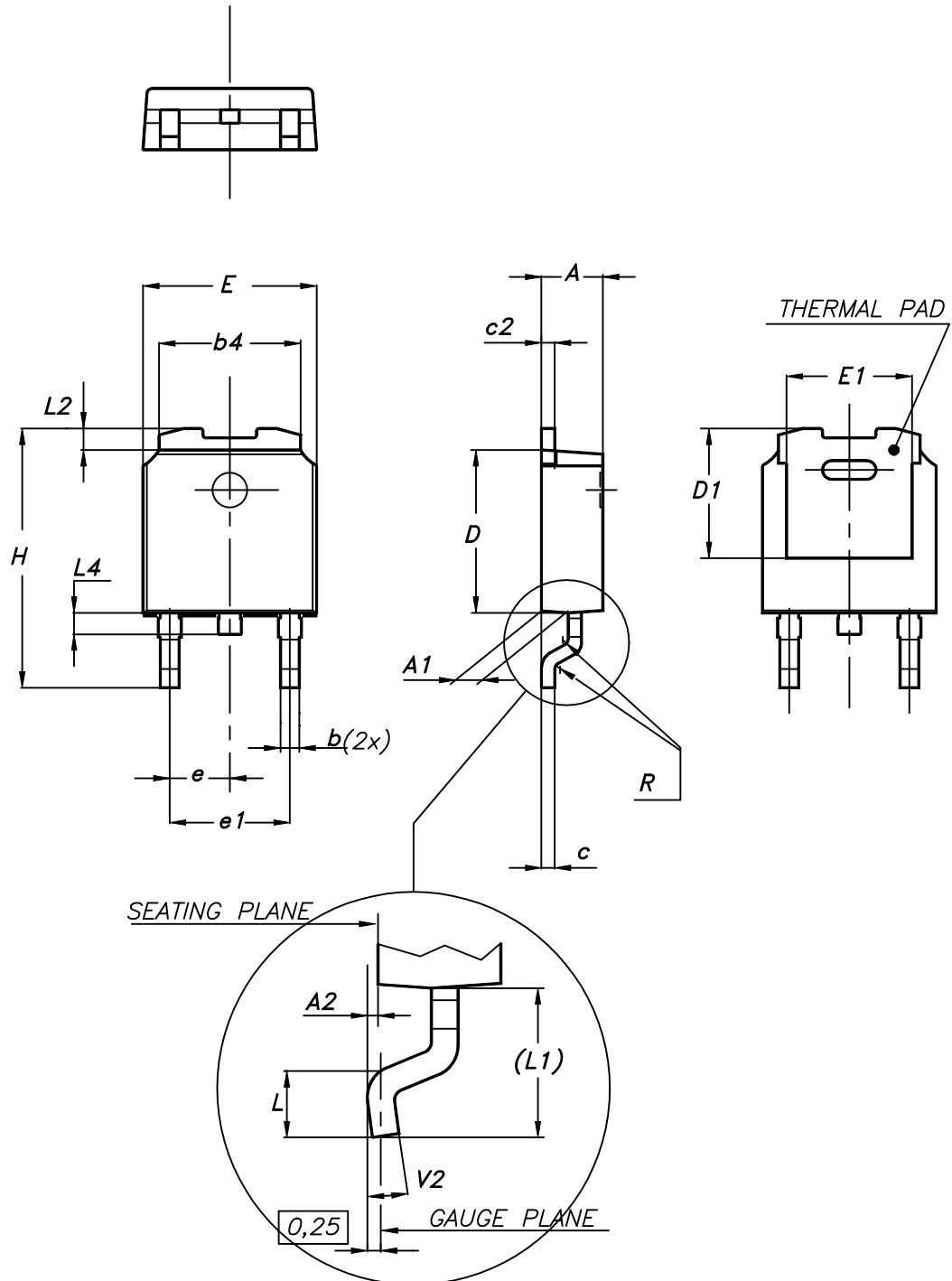

0068772_type-A2_rev25

Table 10. DPAK (TO-252) type A2 mechanical data

Dim.	mm		
	Min.	Typ.	Max.
A	2.20		2.40
A1	0.90		1.10
A2	0.03		0.23
b	0.64		0.90
b4	5.20		5.40
c	0.45		0.60
c2	0.48		0.60
D	6.00		6.20
D1	4.95	5.10	5.25
E	6.40		6.60
E1	5.10	5.20	5.30
e	2.159	2.286	2.413
e1	4.445	4.572	4.699
H	9.35		10.10
L	1.00		1.50
L1	2.60	2.80	3.00
L2	0.65	0.80	0.95
L4	0.60		1.00
R		0.20	
V2	0°		8°

4.4 DPAK (TO-252) type C2 package information

Figure 43. DPAK (TO-252) type C2 package outline

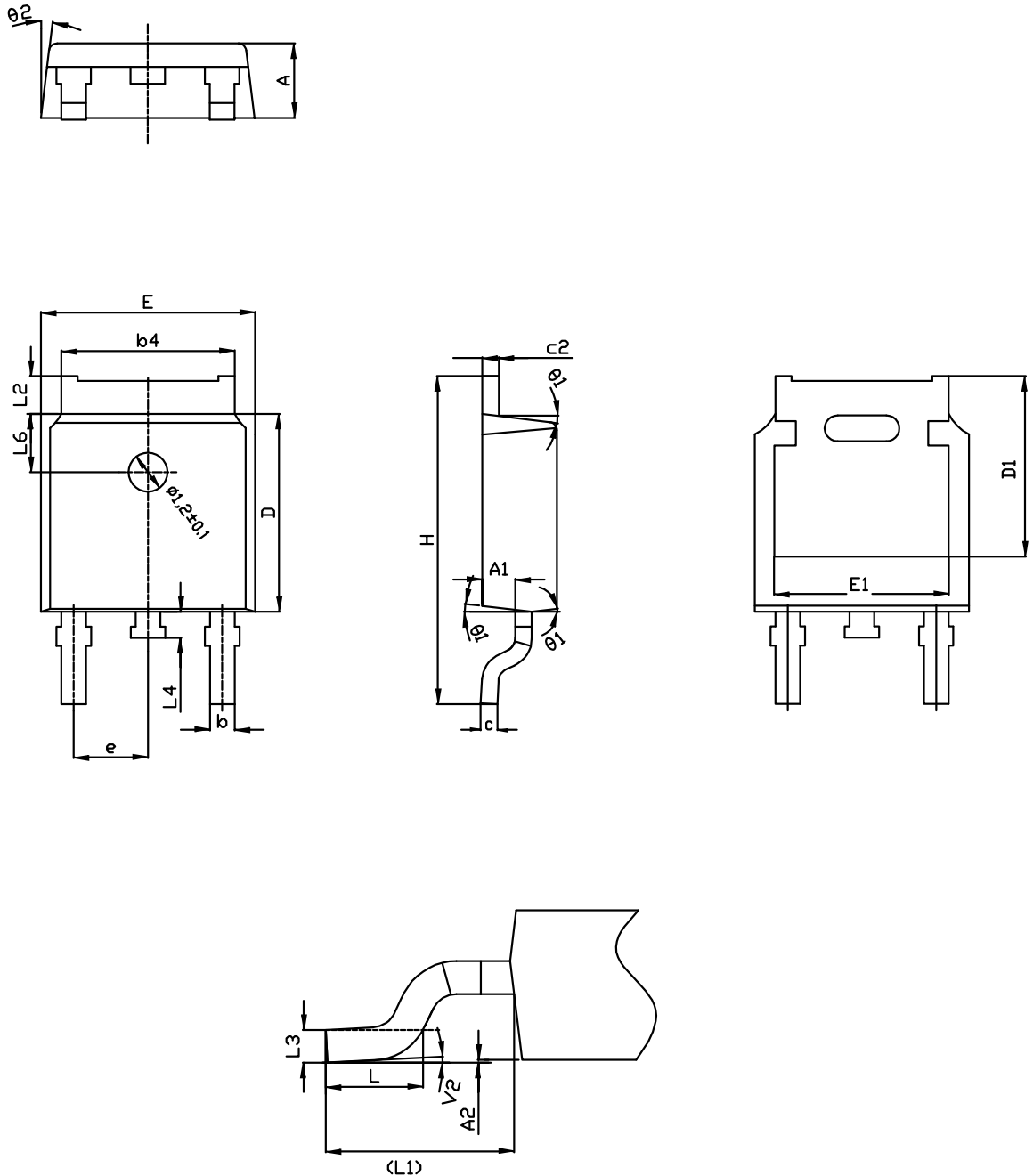

0068772_C2_25

Table 11. DPAK (TO-252) type C2 mechanical data

Dim.	mm		
	Min.	Typ.	Max.
A	2.20	2.30	2.38
A1	0.90	1.01	1.10
A2	0.00		0.10
b	0.72		0.85
b4	5.13	5.33	5.46
c	0.47		0.60
c2	0.47		0.60
D	6.00	6.10	6.20
D1	5.10		5.60
E	6.50	6.60	6.70
E1	5.20		5.50
e	2.186	2.286	2.386
H	9.80	10.10	10.40
L	1.40	1.50	1.70
L1	2.90 REF		
L2	0.90		1.25
L3	0.51 BSC		
L4	0.60	0.80	1.00
L6	1.80 BSC		
θ1	5°	7°	9°
θ2	5°	7°	9°
V2	0°		8°

4.5 DPAK (TO-252) packing information

Figure 44. DPAK (TO-252) tape outline

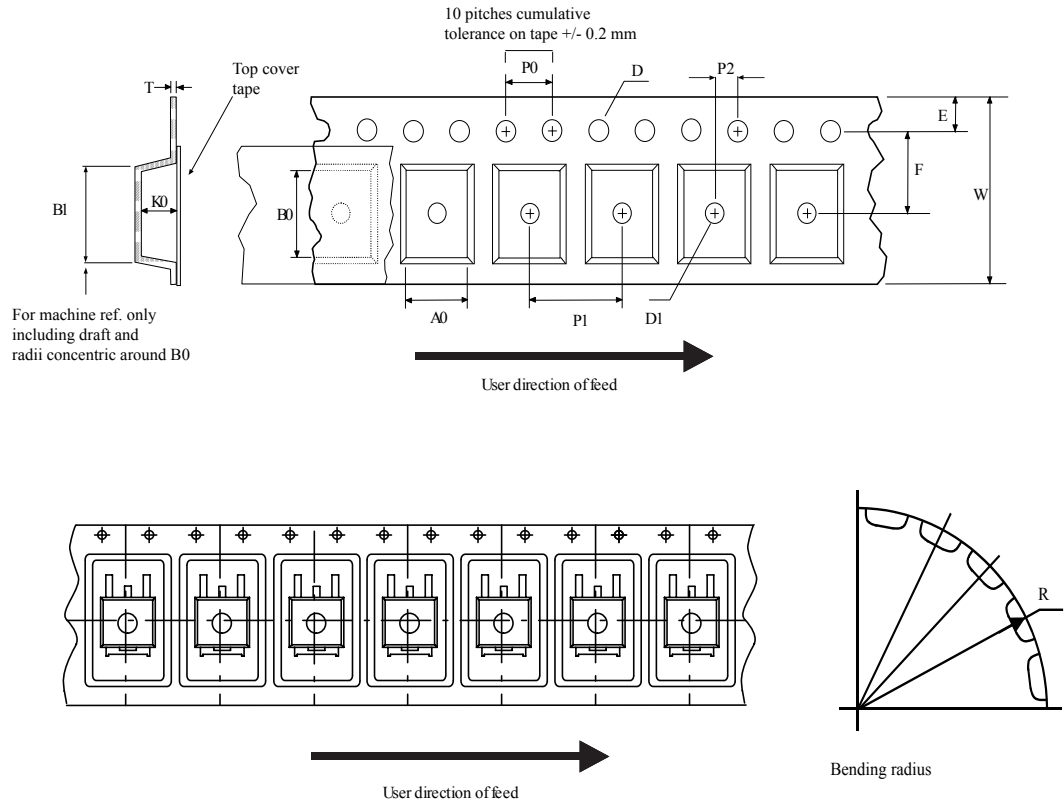

AM08852v1

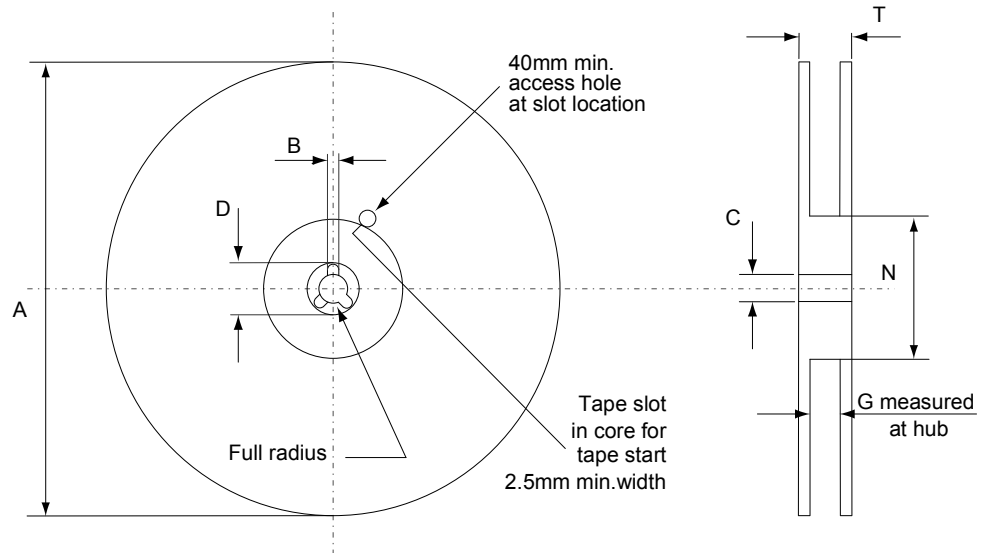
Figure 45. DPAK (TO-252) reel outline

AM06038v1

Table 12. DPAK (TO-252) tape and reel mechanical data

Tape			Reel		
Dim.	mm		Dim.	mm	
	Min.	Max.		Min.	Max.
A0	6.8	7	A		330
B0	10.4	10.6	B	1.5	
B1		12.1	C	12.8	13.2
D	1.5	1.6	D	20.2	
D1	1.5		G	16.4	18.4
E	1.65	1.85	N	50	
F	7.4	7.6	T		22.4
K0	2.55	2.75			
P0	3.9	4.1	Base qty.		2500
P1	7.9	8.1	Bulk qty.		2500
P2	1.9	2.1			
R	40				
T	0.25	0.35			
W	15.7	16.3			

4.6 TO-220FP package information

Figure 46. TO-220FP package outline

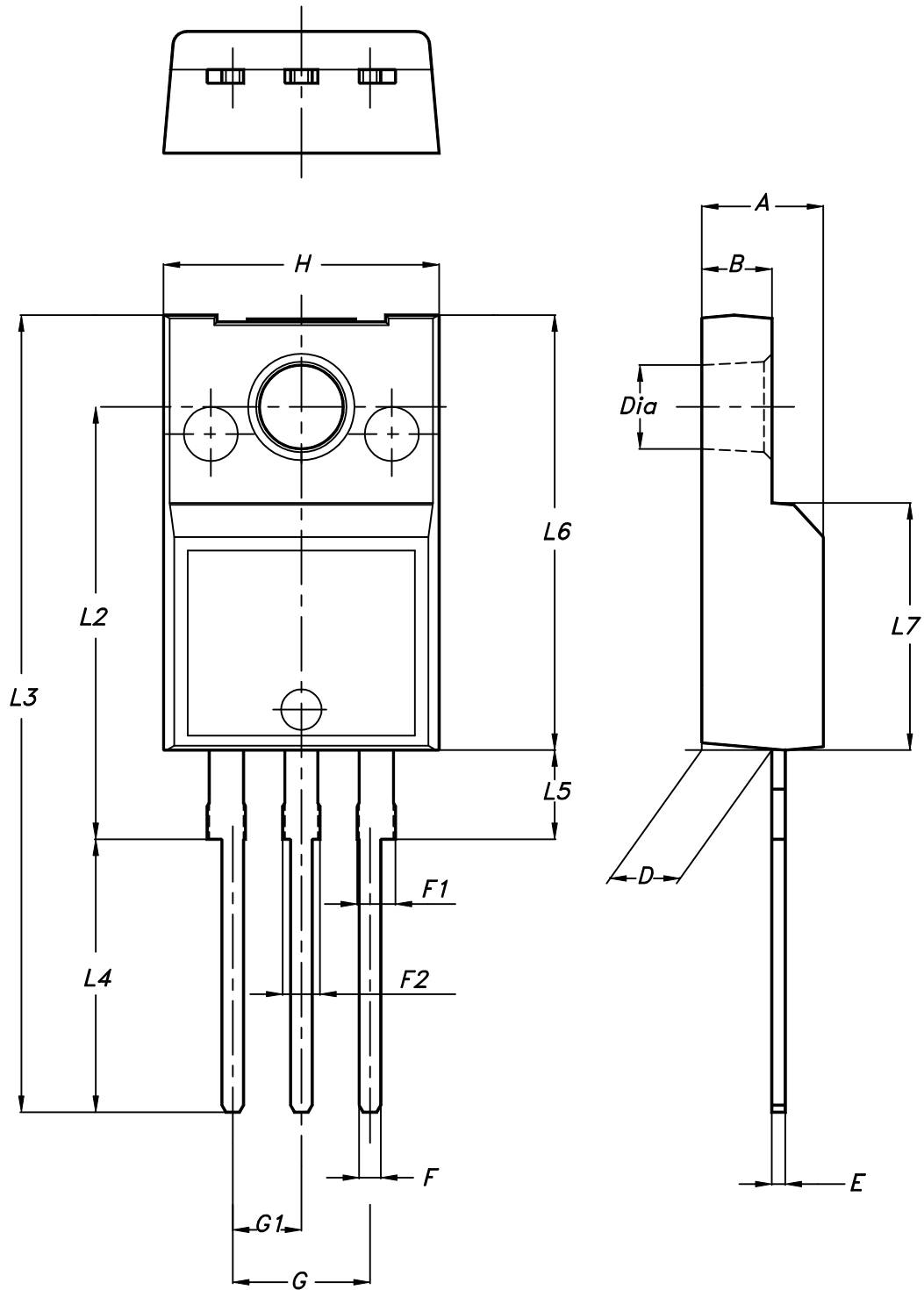

7012510_Rev_12_B

Table 13. TO-220FP package mechanical data

Dim.	mm		
	Min.	Typ.	Max.
A	4.4		4.6
B	2.5		2.7
D	2.5		2.75
E	0.45		0.7
F	0.75		1
F1	1.15		1.70
F2	1.15		1.70
G	4.95		5.2
G1	2.4		2.7
H	10		10.4
L2		16	
L3	28.6		30.6
L4	9.8		10.6
L5	2.9		3.6
L6	15.9		16.4
L7	9		9.3
Dia	3		3.2

4.7 TO-220 type A package information

Figure 47. TO-220 type A package outline

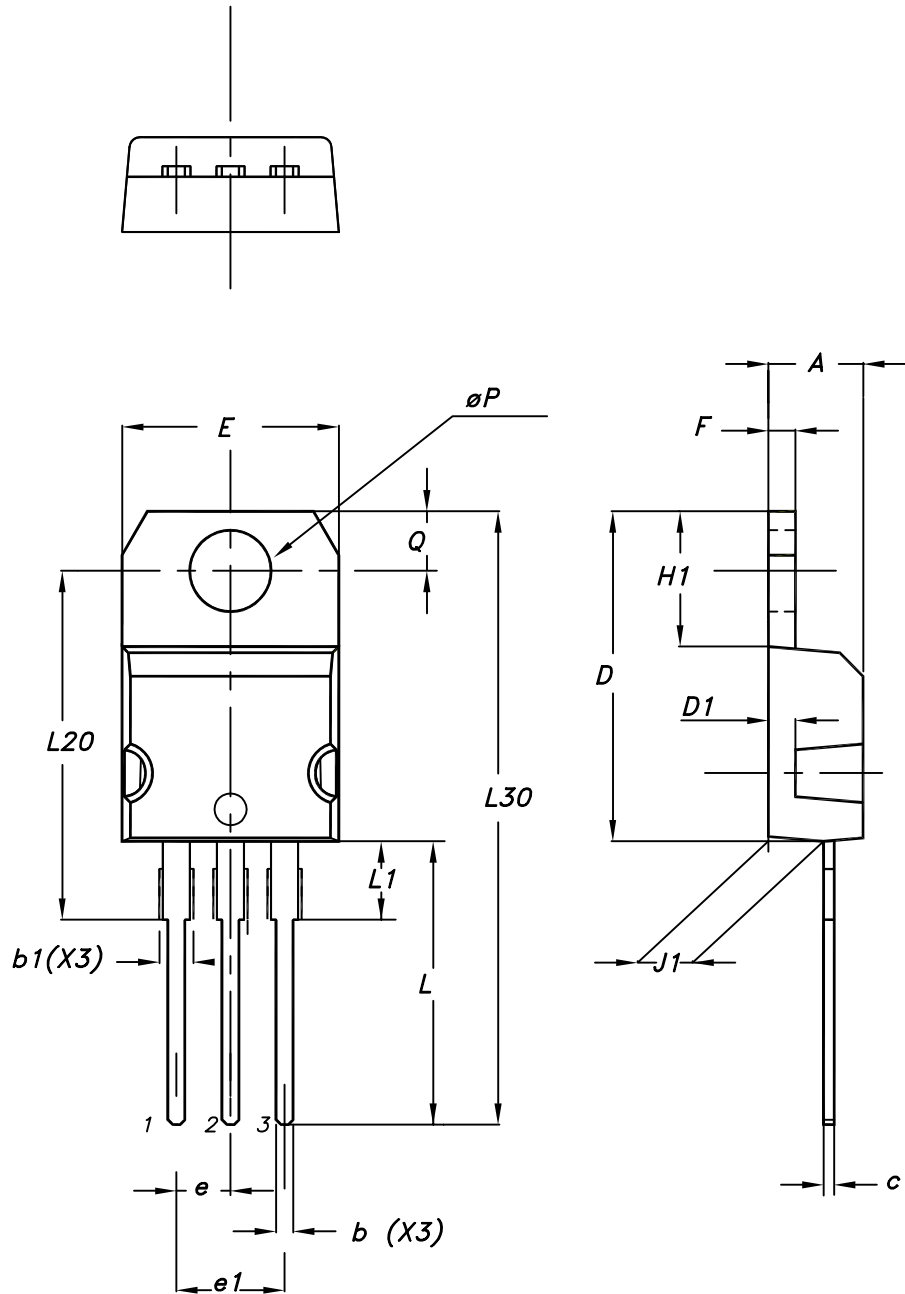

0015988_typeA_Rev_21

Table 14. TO-220 type A package mechanical data

Dim.	mm		
	Min.	Typ.	Max.
A	4.40		4.60
b	0.61		0.88
b1	1.14		1.55
c	0.48		0.70
D	15.25		15.75
D1		1.27	
E	10.00		10.40
e	2.40		2.70
e1	4.95		5.15
F	1.23		1.32
H1	6.20		6.60
J1	2.40		2.72
L	13.00		14.00
L1	3.50		3.93
L20		16.40	
L30		28.90	
øP	3.75		3.85
Q	2.65		2.95

5 Ordering information

Table 15. Order codes

Order code	Marking	Package	Packing
STGB5H60DF	GB5H60DF	D ² PAK	Tape and reel
STGD5H60DF	GD5H60DF	DPAK	
STGF5H60DF	GF5H60DF	TO-220FP	Tube
STGP5H60DF	GP5H60DF	TO-220	

Revision history

Table 16. Document revision history

Date	Version	Changes
28-Nov-2014	1	Initial release.
23-Feb-2015	2	Updated <i>Section 2: Electrical characteristics</i> and <i>Section 4: Package information</i> . Minor text changes.
18-May-2015	3	Text and formatting changes throughout document In <i>Section 1: Electrical ratings</i> : - updated <i>Table 2</i> and <i>Table 3</i> In <i>Section 2: Electrical characteristics</i> : - updated <i>Table 4</i> , <i>Table 5</i> , <i>Table 6</i> , <i>Table 7</i> and <i>Table 8</i> Added <i>Section 2.1: Electrical characteristics (curves)</i> Updated <i>Section 4.2: DPAK package information</i> Document status promoted from "preliminary data" to "production data"
18-Sep-2018	4	Removed maturity status indication from cover page. Updated Section 4 Package information . Minor text changes.

Contents

1	Electrical ratings	2
2	Electrical characteristics	3
2.1	Electrical characteristics curves	5
3	Test circuits	11
4	Package information	12
4.1	D ² PAK (TO-263) type A package information	12
4.2	D ² PAK packing information	15
4.3	DPAK (TO-252) type A2 package information	17
4.4	DPAK (TO-252) type C2 package information	19
4.5	DPAK (TO-252) packing information	21
4.6	TO-220FP package information	23
4.7	TO-220 type A package information	25
5	Ordering information	28
	Revision history	29



IMPORTANT NOTICE – PLEASE READ CAREFULLY

STMicroelectronics NV and its subsidiaries (“ST”) reserve the right to make changes, corrections, enhancements, modifications, and improvements to ST products and/or to this document at any time without notice. Purchasers should obtain the latest relevant information on ST products before placing orders. ST products are sold pursuant to ST’s terms and conditions of sale in place at the time of order acknowledgement.

Purchasers are solely responsible for the choice, selection, and use of ST products and ST assumes no liability for application assistance or the design of Purchasers’ products.

No license, express or implied, to any intellectual property right is granted by ST herein.

Resale of ST products with provisions different from the information set forth herein shall void any warranty granted by ST for such product.

ST and the ST logo are trademarks of ST. All other product or service names are the property of their respective owners.

Information in this document supersedes and replaces information previously supplied in any prior versions of this document.

© 2018 STMicroelectronics – All rights reserved

单击下面可查看定价，库存，交付和生命周期等信息

[>>STMicroelectronics\(意法半导体\)](#)