

# F873 Series Polypropylene Metallized Film, Class X1, 760 VAC

## Overview

Metallized polypropylene film encapsulated with self-extinguishing resin in a box of material recognized to UL 94 V-0.

## Applications

For worldwide use as electromagnetic interference (EMI) suppression filter in across-the-line applications requiring X1 safety classification.

## Benefits

- Approvals: ENEC, UL, cUL, CQC
- Rated voltage: 760 VAC 50/60 Hz
- Capacitance range: 0.01 – 1.8  $\mu$ F
- Lead spacing: 22.5 – 37.5 mm
- Capacitance tolerance:  $\pm$ 20%,  $\pm$ 10%
- Climatic category 40/110/56, IEC 60068-1
- Tape and reel in accordance with IEC 60286-2
- RoHS Compliant and lead-free terminations
- Operating temperature range of  $-40^{\circ}\text{C}$  to  $+110^{\circ}\text{C}$
- 100% screening factory test at 4,250 VDC

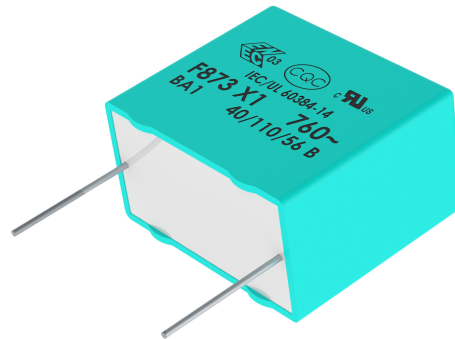

## Part Number System

F	873	D	U	104	M	760	C
Capacitor Class	Series	Lead Spacing (mm)	Size Code	Capacitance Code (pF)	Capacitance Tolerance	Voltage (VAC)	Packaging
F = Film	X1, Metallized Polypropylene	D = 22.5 F = 27.5 R = 37.5	See Dimension Table	First two digits represent significant figures. Third digit specifies number of zeros.	K = $\pm$ 10% M = $\pm$ 20%	760	See Ordering Options Table

## Ordering Options Table

Lead Spacing Nominal (mm)	Type of Leads and Packaging	Lead Length (mm)	Lead and Packaging Code
22.5	<b>Standard Lead and Packaging Options</b>		
	Pizza – Long Leads	17+0/-1	ZLH0J
	Pizza Pack	4+2/-0	Z
	<b>Other Lead and Packaging Options</b>		
	Tape & Reel (Standard Reel)	$H_0 = 18.5+/-0.5$	L
	Tape & Reel (Large Reel)	$H_0 = 18.5+/-0.5$	P
	Ammo Pack	$H_0 = 18.5+/-0.5$	R
27.5	<b>Standard Lead and Packaging Options</b>		
	Pizza – Long Leads	17+0/-1	ZLH0J
	Pizza Pack	4+2/-0	Z
37.5	<b>Standard Lead and Packaging Options</b>		
	Pizza – Long Leads	17+0/-1	ZLH0J
	Pizza Pack	4+2/-0	Z

## Dimensions – Millimeters

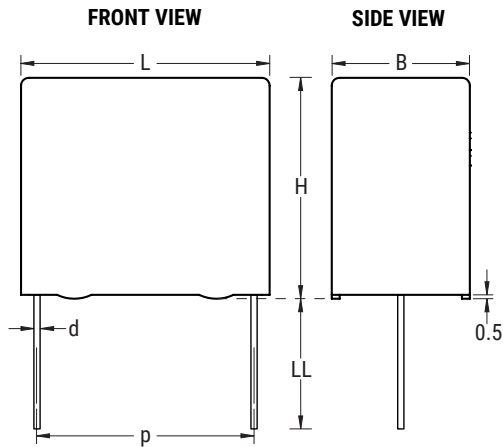

Size Code	Version	p		B		H		L		d	
		Nominal	Tolerance	Nominal	Tolerance	Nominal	Tolerance	Nominal	Tolerance	Nominal	Tolerance
DB		22.5	+/-0.4	6.0	Maximum	14.5	Maximum	26.0	Maximum	0.8	+/-0.05
DI		22.5	+/-0.4	7.0	Maximum	16.0	Maximum	26.0	Maximum	0.8	+/-0.05
DH		22.5	+/-0.4	8.0	Maximum	16.0	Maximum	26.0	Maximum	0.8	+/-0.05
DJ		22.5	+/-0.4	8.5	Maximum	17.0	Maximum	26.0	Maximum	0.8	+/-0.05
DM		22.5	+/-0.4	9.0	Maximum	18.5	Maximum	26.0	Maximum	0.8	+/-0.05
DO		22.5	+/-0.4	10.0	Maximum	18.5	Maximum	26.0	Maximum	0.8	+/-0.05
DP		22.5	+/-0.4	11.0	Maximum	20.0	Maximum	26.0	Maximum	0.8	+/-0.05
DU		22.5	+/-0.4	13.0	Maximum	22.0	Maximum	26.0	Maximum	0.8	+/-0.05
DY		22.5	+/-0.4	15.5	Maximum	24.5	Maximum	26.0	Maximum	0.8	+/-0.05
FB		27.5	+/-0.4	9.0	Maximum	17.0	Maximum	31.5	Maximum	0.8	+/-0.05
FC		27.5	+/-0.4	11.0	Maximum	20.0	Maximum	31.5	Maximum	0.8	+/-0.05
FI		27.5	+/-0.4	13.0	Maximum	25.0	Maximum	31.5	Maximum	0.8	+/-0.05
FN		27.5	+/-0.4	14.0	Maximum	28.0	Maximum	31.5	Maximum	0.8	+/-0.05
FO	High Profile	27.5	+/-0.4	17.0	Maximum	40.0	Maximum	31.5	Maximum	0.8	+/-0.05
FR		27.5	+/-0.4	17.5	Maximum	28.0	Maximum	31.5	Maximum	0.8	+/-0.05
FS		27.5	+/-0.4	19.0	Maximum	29.0	Maximum	31.5	Maximum	0.8	+/-0.05
FY		27.5	+/-0.4	22.0	Maximum	37.0	Maximum	31.5	Maximum	0.8	+/-0.05
FH	Low Profile	27.5	+/-0.4	21.0	Maximum	12.5	Maximum	31.5	Maximum	0.8	+/-0.05
FQ	Low Profile	27.5	+/-0.4	27.5	Maximum	16.0	Maximum	31.5	Maximum	0.8	+/-0.05
FT	Low Profile	27.5	+/-0.4	31.0	Maximum	19.0	Maximum	31.5	Maximum	0.8	+/-0.05
RB		37.5	+/-0.4	11.0	Maximum	22.0	Maximum	41.0	Maximum	1	+/-0.05
RF		37.5	+/-0.4	13.0	Maximum	24.0	Maximum	41.0	Maximum	1	+/-0.05
RH		37.5	+/-0.4	15.0	Maximum	26.0	Maximum	41.0	Maximum	1	+/-0.05
RC		37.5	+/-0.4	16.0	Maximum	28.5	Maximum	41.0	Maximum	1	+/-0.05
RD		37.5	+/-0.4	19.0	Maximum	32.0	Maximum	41.0	Maximum	1	+/-0.05
RP		37.5	+/-0.4	21.0	Maximum	38.0	Maximum	41.0	Maximum	1	+/-0.05
RO		37.5	+/-0.4	24.0	Maximum	44.0	Maximum	41.0	Maximum	1	+/-0.05
RU		37.5	+/-0.4	30.0	Maximum	45.0	Maximum	41.0	Maximum	1	+/-0.05
RV	Low Profile	37.5	+/-0.4	24.0	Maximum	15.0	Maximum	41.0	Maximum	1	+/-0.05
RW	Low Profile	37.5	+/-0.4	24.0	Maximum	19.0	Maximum	41.0	Maximum	1	+/-0.05

**Note: See Ordering Options Table for lead length (LL) options.**

## Performance Characteristics

Rated Voltage	760 VAC 50/60 Hz		
Capacitance Range	0.01 – 1.8 $\mu$ F		
Capacitance Tolerance	$\pm$ 20%, $\pm$ 10%		
Temperature Range	-40°C to +110°C		
Climatic Category	40/110/56		
Storage Conditions	Storage time: $\leq$ 24 months from the date marked on the label package Average relative humidity per year $\leq$ 70% RH $\leq$ 85% for 30 days randomly distributed throughout the year Dew is absent Temperature: -40 to 80°C (see "Maximum Humidity in Storage Conditions" graph below)		
Approvals	ENEC, UL, cUL, CQC		
Dissipation Factor	Maximum Values at +23°C		
		$C \leq 0.1 \mu$ F	$C > 0.1 \mu$ F
	1 kHz	0.1%	0.1%
Test Voltage Between Terminals	The 100% screening factory test is carried out at 4,250 VDC. The voltage level is selected to meet the requirements in applicable equipment standards. All electrical characteristics are checked after the test. It's not permitted to repeat this Test as there is a risk to damage the Capacitor. KEMET is not liable in such case for any failures.		
Insulation Resistance	Minimum Values Between Terminals		
	$C \leq 0.33 \mu$ F	$\geq 30,000 \text{ M}\Omega$	
	$C > 0.33 \mu$ F	$\geq 10,000 \text{ M}\Omega \cdot \mu$ F	
In DC Applications	Recommended voltage $\leq$ 1,500 VDC		

### Maximum Humidity in Storage Conditions

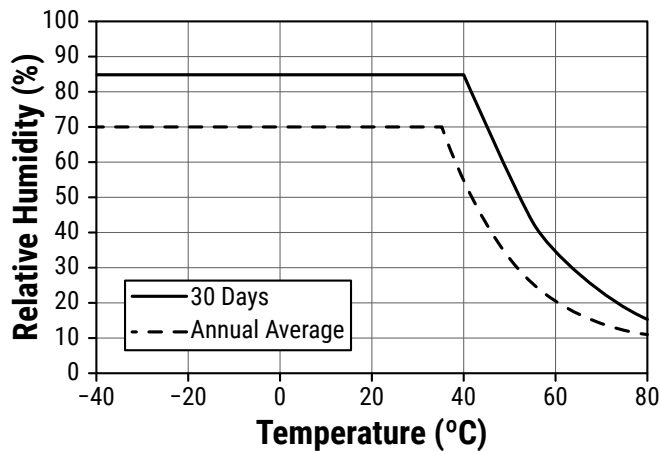

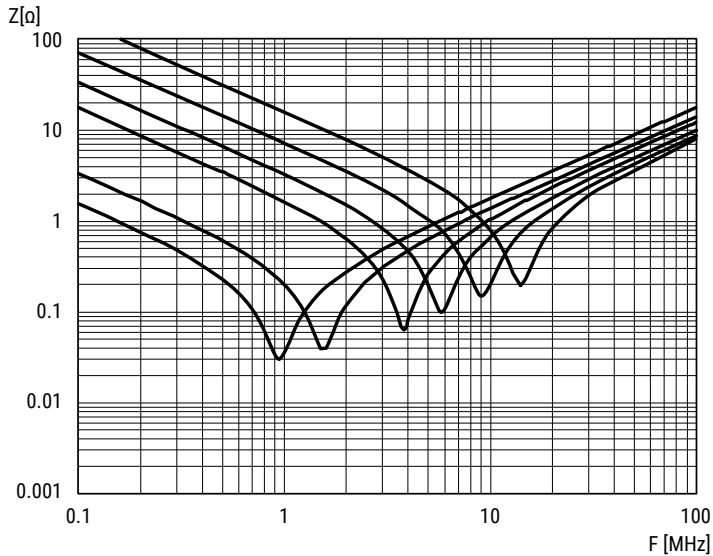

## Impedance Graph



## Environmental Test Data

Test	IEC Publication	Procedure
Endurance	IEC 60384-14	1.25 x V <sub>R</sub> VAC 50 Hz, once every hour increase to 1,000 VAC for 0.1 second, 1,000 hours at upper rated temperature
Vibration	IEC 60068-2-6 Test Fc	3 directions at 2 hours each 10 – 55 Hz at 0.75 mm or 98 m/s <sup>2</sup>
Bump	IEC 60068-2-29 Test Eb	1,000 bumps at 390 m/s <sup>2</sup>
Change of Temperature	IEC 60068-2-14 Test Na	Upper and lower rated temperature 5 cycles
Active Flammability	IEC 60384-14	V <sub>R</sub> + 20 surge pulses at 4 kV (pulse every 5 seconds)
Passive Flammability	IEC 60384-14	IEC 60384-1, IEC 60695-11-5 Needle-flame test
Damp Heat Steady State	IEC 60068-2-78 Test Cab	+40°C and 93% RH, 56 days

## Approvals

Mark	Specification	File Number
	EN/IEC 60384-14	CA08.00188
	UL 60384-14 and CAN/CSA-E60384-14	E97797
	IEC 60384-14	CQC12001084815 CQC12001084817 CQC12001084814 CQC12001084820 CQC12001086324 CQC12001088068

## Environmental Compliance

All new KEMET EMI capacitors are RoHS Compliant and Halogen Free.



**Table 1 – Ratings & Part Number Reference**

Capacitance Value (µF)	Size Code	Maximum Dimensions in mm			Lead Spacing (p)	dV/dt (V/µs)	Part Number
		B	H	L			
0.01	DB	6	14.5	26	22.5	300	F873DB103(1)760(2)
0.012	DB	6	14.5	26	22.5	300	F873DB123(1)760(2)
0.015	DB	6	14.5	26	22.5	300	F873DB153(1)760(2)
0.018	DB	6	14.5	26	22.5	300	F873DB183(1)760(2)
0.022	DB	6	14.5	26	22.5	300	F873DB223(1)760(2)
0.025	DB	6	14.5	26	22.5	300	F873DB253(3)760(2)
0.025	DI	7	16	26	22.5	300	F873DI253(1)760(2)
0.027	DI	7	16	26	22.5	300	F873DI273(1)760(2)
0.033	DI	7	16	26	22.5	300	F873DI333(1)760(2)
0.039	DI	7	16	26	22.5	300	F873DI393(1)760(2)
0.047	DH	8	16	26	22.5	300	F873DH473(3)760(2)
0.047	DJ	8.5	17	26	22.5	300	F873DJ473(1)760(2)
0.056	DJ	8.5	17	26	22.5	300	F873DJ563(3)760(2)
0.056	DM	9	18.5	26	22.5	300	F873DM563(1)760(2)
0.068	DO	10	18.5	26	22.5	300	F873DO683(1)760(2)
0.082	DO	10	18.5	26	22.5	300	F873DO823(3)760(2)
0.082	DP	11	20	26	22.5	300	F873DP823(1)760(2)
0.1	DP	11	20	26	22.5	300	F873DP104(3)760(2)
0.1	DU	13	22	26	22.5	300	F873DU104(1)760(2)
0.12	DU	13	22	26	22.5	300	F873DU124(1)760(2)
0.15	DY	15.5	24.5	26	22.5	300	F873DY154(1)760(2)
0.18	DY	15.5	24.5	26	22.5	300	F873DY184(1)760(2)
0.056	FB	9	17	31.5	27.5	225	F873FB563(1)760(2)
0.068	FB	9	17	31.5	27.5	225	F873FB683(1)760(2)
0.082	FB	9	17	31.5	27.5	225	F873FB823(3)760(2)
0.082	FC	11	20	31.5	27.5	225	F873FC823(1)760(2)
0.1	FC	11	20	31.5	27.5	225	F873FC104(1)760(2)
0.1	FH	21	12.5	31.5	27.5	225	F873FH104(1)760(2)
0.12	FC	11	20	31.5	27.5	225	F873FC124(3)760(2)
0.12	FH	21	12.5	31.5	27.5	225	F873FH124(1)760(2)
0.15	FH	21	12.5	31.5	27.5	225	F873FH154(3)760(2)
0.15	FI	13	25	31.5	27.5	225	F873FI154(1)760(2)
0.18	FI	13	25	31.5	27.5	225	F873FI184(1)760(2)
0.22	FI	13	25	31.5	27.5	225	F873FI224(3)760(2)
0.22	FN	14	28	31.5	27.5	225	F873FN224(1)760(2)
0.22	FQ	27.5	16	31.5	27.5	225	F873FQ224(1)760(2)
0.25	FN	14	28	31.5	27.5	225	F873FN254(3)760(2)
0.25	FO	17	40	31.5	27.5	225	F873FO254(1)760(2)
0.25	FQ	27.5	16	31.5	27.5	225	F873FQ254(3)760(2)
0.25	FR	17.5	28	31.5	27.5	225	F873FR254(1)760(2)
0.27	FO	17	40	31.5	27.5	225	F873FO274(1)760(2)
0.27	FR	17.5	28	31.5	27.5	225	F873FR274(1)760(2)
0.27	FT	31	19	31.5	27.5	225	F873FT274(1)760(2)
0.33	FO	17	40	31.5	27.5	225	F873FO334(1)760(2)
0.33	FR	17.5	28	31.5	27.5	225	F873FR334(3)760(2)
0.33	FS	19	29	31.5	27.5	225	F873FS334(1)760(2)
0.33	FT	31	19	31.5	27.5	225	F873FT334(1)760(2)
0.39	FO	17	40	31.5	27.5	225	F873FO394(1)760(2)
0.39	FS	19	29	31.5	27.5	225	F873FS394(3)760(2)
0.39	FY	22	37	31.5	27.5	225	F873FY394(1)760(2)
0.47	FY	22	37	31.5	27.5	225	F873FY474(1)760(2)
0.56	FY	22	37	31.5	27.5	225	F873FY564(1)760(2)
0.15	RB	11	22	41	37.5	150	F873RB154(1)760(2)
0.18	RB	11	22	41	37.5	150	F873RB184(1)760(2)
0.22	RB	11	22	41	37.5	150	F873RB224(3)760(2)
0.22	RV	24	15	41	37.5	150	F873RV224(1)760(2)
0.25	RF	13	24	41	37.5	150	F873RF254(1)760(2)
Capacitance Value (µF)	Size Code	B (mm)	H (mm)	L (mm)	Lead Spacing (p)	dV/dt (V/µs)	Part Number

(1) M = ±20%, K = ±10%.

(2) Insert lead and packaging code. See table for available options.

(3) M = ±20% (only available tolerance).

**Table 1 – Ratings & Part Number Reference cont'd**

Capacitance Value (µF)	Size Code	Maximum Dimensions in mm			Lead Spacing (p)	dV/dt (V/µs)	Part Number
		B	H	L			
0.25	RV	24	15	41	37.5	150	F873RV254(1)760(2)
0.27	RF	13	24	41	37.5	150	F873RF274(1)760(2)
0.27	RV	24	15	41	37.5	150	F873RV274(1)760(2)
0.33	RF	13	24	41	37.5	150	F873RF334(3)760(2)
0.33	RH	15	26	41	37.5	150	F873RH334(1)760(2)
0.33	RV	24	15	41	37.5	150	F873RV334(3)760(2)
0.33	RW	24	19	41	37.5	150	F873RW334(1)760(2)
0.39	RC	16	28.5	41	37.5	150	F873RC394(1)760(2)
0.39	RW	24	19	41	37.5	150	F873RW394(1)760(2)
0.47	RC	16	28.5	41	37.5	150	F873RC474(3)760(2)
0.47	RD	19	32	41	37.5	150	F873RD474(1)760(2)
0.47	RW	24	19	41	37.5	150	F873RW474(3)760(2)
0.56	RD	19	32	41	37.5	150	F873RD564(1)760(2)
0.68	RD	19	32	41	37.5	150	F873RD684(3)760(2)
0.68	RP	21	38	41	37.5	150	F873RP684(1)760(2)
0.82	RO	24	44	41	37.5	150	F873RO824(1)760(2)
0.82	RP	21	38	41	37.5	150	F873RP824(3)760(2)
1	RO	24	44	41	37.5	150	F873RO105(1)760(2)
1.2	RO	24	44	41	37.5	150	F873RO125(1)760(2)
1.5	RU	30	45	41	37.5	150	F873RU155(1)760(2)
1.8	RU	30	45	41	37.5	150	F873RU185(3)760(2)
Capacitance Value (µF)	Size Code	B (mm)	H (mm)	L (mm)	Lead Spacing (p)	dV/dt (V/µs)	Part Number

(1) M = ±20%, K = ±10%.

(2) Insert lead and packaging code. See table for available options.

(3) M = ±20% (only available tolerance).



## Soldering Process

The implementation of the RoHS directive has resulted in the selection of SnAgCu (SAC) alloys or SnCu alloys as primary solder. This has increased the liquidus temperature from that of 183°C for SnPb eutectic alloy to 217 – 221°C for the new alloys. As a result, the heat stress to the components, even in wave soldering, has increased considerably due to higher pre-heat and wave temperatures. Polypropylene capacitors are especially sensitive to heat (the melting point of polypropylene is 160 – 170°C). Wave soldering can be destructive, especially for mechanically small polypropylene capacitors (with lead spacing of 5 mm to 15 mm), and great care has to be taken during soldering. The recommended solder profiles from KEMET should be used. Please consult KEMET with any questions. In general, the wave soldering curve from IEC Publication 61760–1 Edition 2 serves as a solid guideline for successful soldering. Please see Figure 1.

Reflow soldering is not recommended for through-hole film capacitors. Exposing capacitors to a soldering profile in excess of the above the recommended limits may result to degradation or permanent damage to the capacitors.

Do not place the polypropylene capacitor through an adhesive curing oven to cure resin for surface mount components. Insert through-hole parts after the curing of surface mount parts. Consult KEMET to discuss the actual temperature profile in the oven, if through-hole components must pass through the adhesive curing process. A maximum two soldering cycles is recommended. Please allow time for the capacitor surface temperature to return to a normal temperature before the second soldering cycle.

### Manual Soldering Recommendations

Following is the recommendation for manual soldering with a soldering iron.

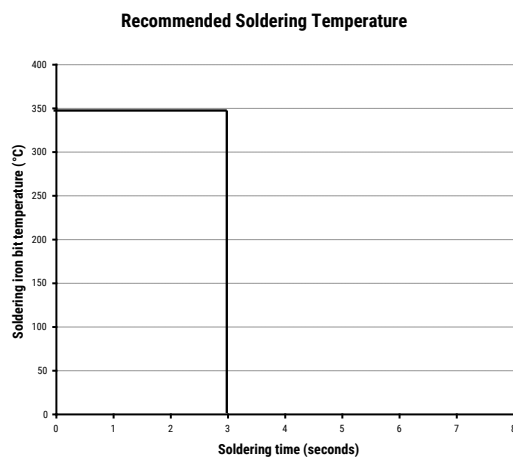

The soldering iron tip temperature should be set at 350°C (+10°C maximum) with the soldering duration not to exceed more than 3 seconds.

### Wave Soldering Recommendations

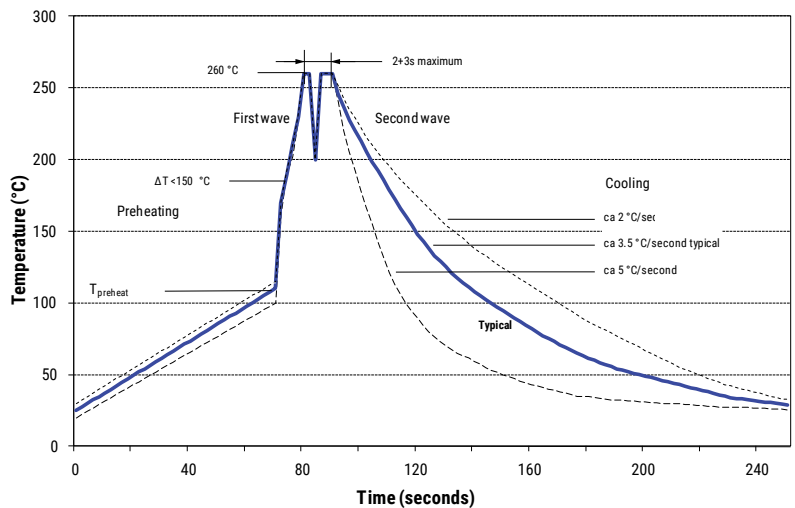

## Soldering Process cont'd

### Wave Soldering Recommendations cont'd

1. The table indicates the maximum set-up temperature of the soldering process  
 Figure 1

Dielectric Film Material	Maximum Preheat Temperature			Maximum Peak Soldering Temperature	
	Capacitor Pitch ≤ 10 mm	Capacitor Pitch = 15 mm	Capacitor Pitch > 15 mm	Capacitor Pitch ≤ 15 mm	Capacitor Pitch > 15 mm
Polyester	130°C	130°C	130°C	270°C	270°C
Polypropylene	100°C	110°C	130°C	260°C	270°C
Paper	130°C	130°C	140°C	270°C	270°C
Polyphenylene Sulphide	150°C	150°C	160°C	270°C	270°C

2. The maximum temperature measured inside the capacitor:

Set the temperature so that inside the element the maximum temperature is below the limit:

Dielectric Film Material	Maximum temperature measured inside the element
Polyester	160°C
Polypropylene	110°C
Paper	160°C
Polyphenylene Sulphide	160°C

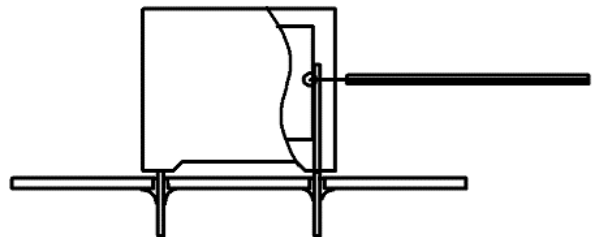

*Temperature monitored inside the capacitor.*

### Selective Soldering Recommendations

Selective dip soldering is a variation of reflow soldering. In this method, the printed circuit board with through-hole components to be soldered is preheated and transported over the solder bath as in normal flow soldering without touching the solder. When the board is over the bath, it is stopped and pre-designed solder pots are lifted from the bath with molten solder only at the places of the selected components, and pressed against the lower surface of the board to solder the components.

The temperature profile for selective soldering is similar to the double wave flow soldering outlined in this document, **however, instead of two baths, there is only one bath with a time from 3 to 10 seconds.** In selective soldering, the risk of overheating is greater than in double wave flow soldering, and great care must be taken so that the parts are not overheated.

## Construction

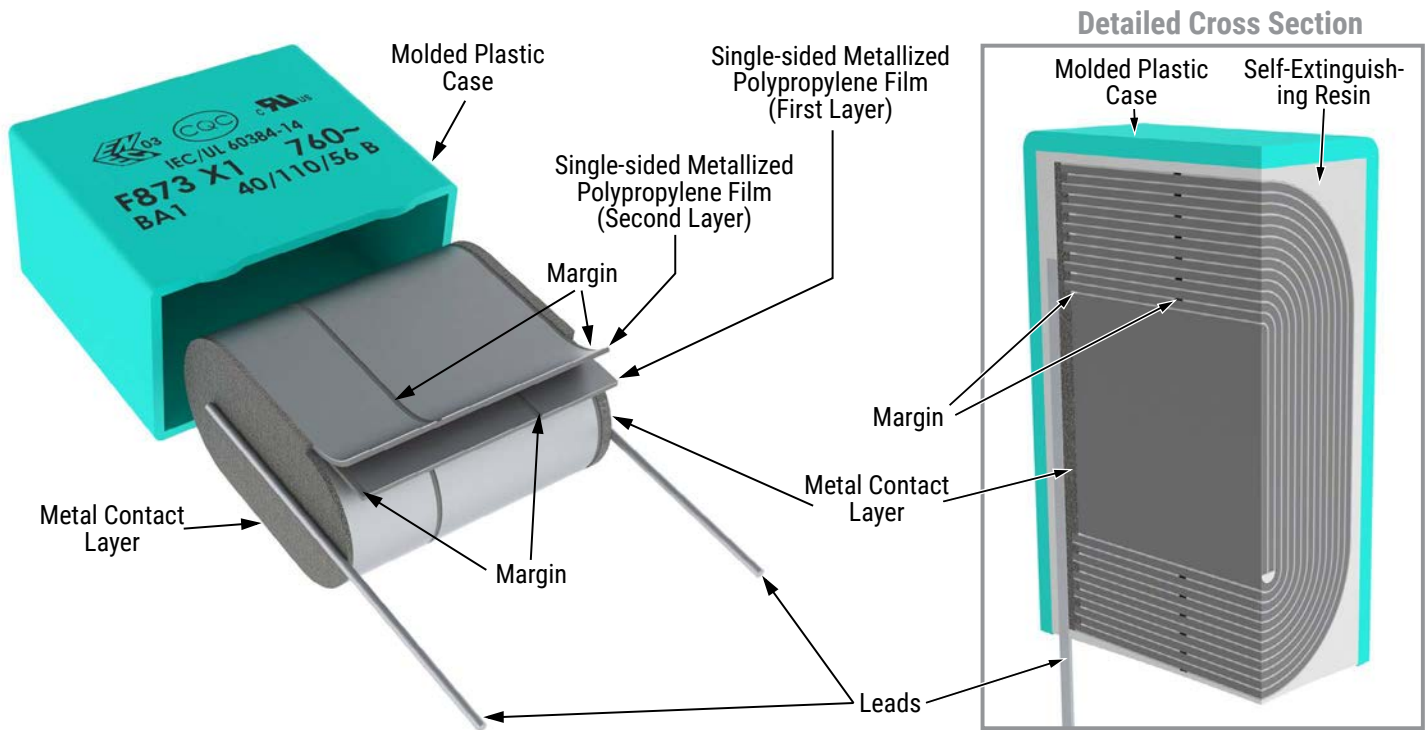

## Winding Scheme

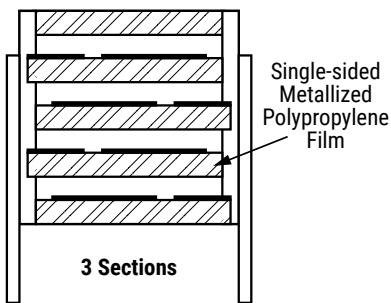

## Marking

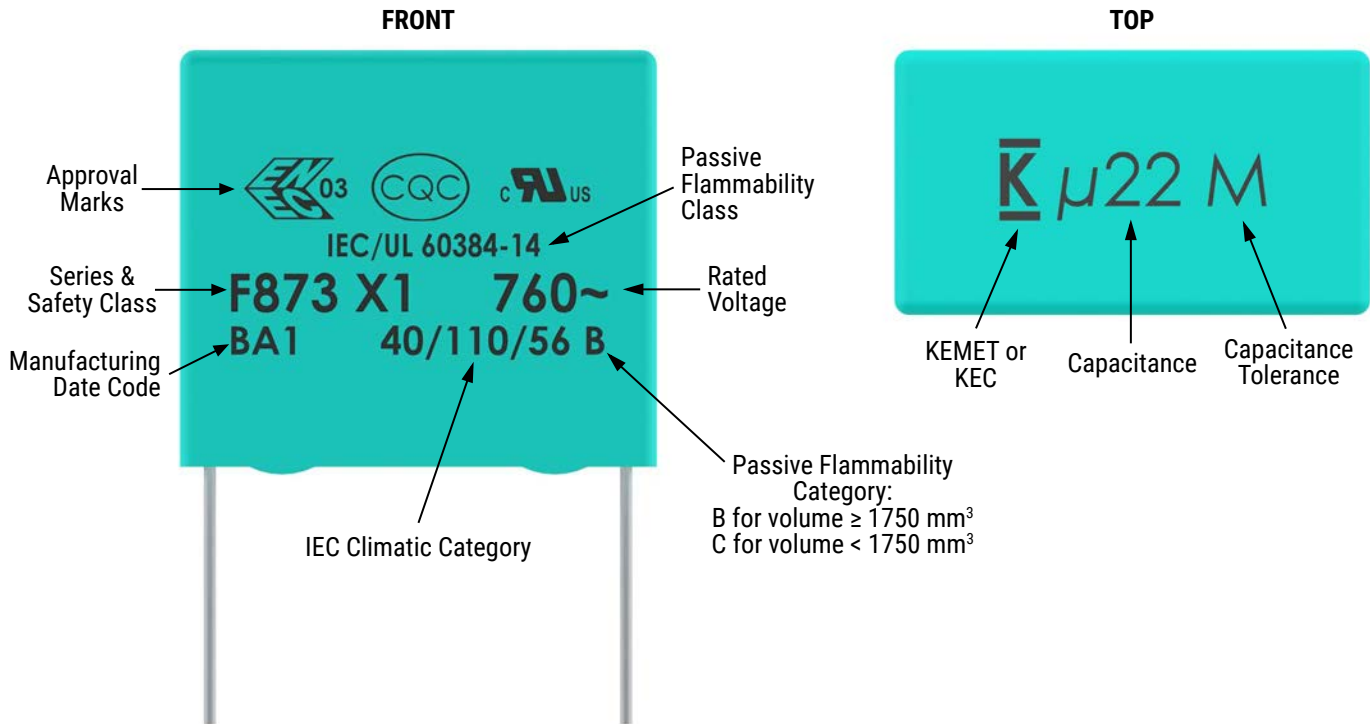

## Packaging Quantities

Size Code	Lead Spacing	Thickness (mm)	Height (mm)	Length (mm)	Bulk Short Leads	Bulk Long Leads	Standard Reel Ø 355 mm	Large Reel Ø 500 mm	Ammo	Pizza
DB	<b>22.5</b>	6	14.5	26	1638	702	300	700	464	660
DI		7	16	26	1188	594	250	550	380	564
DH		8.0	16.0	26	1026	513	240	500	330	492
DJ		8.5	17	26	972	486	250	450	280	468
DM		9	18.5	26	918	459	200	400	300	444
DO		10	18.5	26	810	405	160	350	235	396
DP		11	20	26	756	378	190	350	217	360
DU		13	22	26	540	324	150	300	200	300
DY		15.5	24.5	26	450	270	120	250	170	252
FB	<b>27.5</b>	9.0	17.0	31.5	816	408				370
FC		11.0	20.0	31.5	672	336				300
FI		13.0	25.0	31.5	480	288				250
FN		14.0	28.0	31.5	352	176				230
FO		17.0	40.0	31.5	216	144				190
FR		17.5	28.0	31.5	256	128				190
FS		19.0	29.0	31.5	256	128				170
FY		22.0	37.0	31.5	168	112				150
FH		21.0	12.5	31.5	392	168				150
FQ		27.5	16.0	31.5	280	120				120
FT	31.0	19.0	31.5	240	120				100	
RB	<b>37.5</b>	11.0	22.0	41.0	420	252				210
RF		13.0	24.0	41.0	360	216				175
RH		15.0	26.0	41.0	300	180				154
RC		16.0	28.5	41.0	216	108				140
RD		19.0	32.0	41.0	192	96				119
RP		21.0	38.0	41.0	126	84				105
RO		24.0	44.0	41.0	108	72				91
RU		30.0	45.0	41.0	90	60				77
RV		24.0	15.0	41.0	252	108				91
RW		24.0	19.0	41.0	216	108				91

## Lead Taping & Packaging (IEC 60286-2)

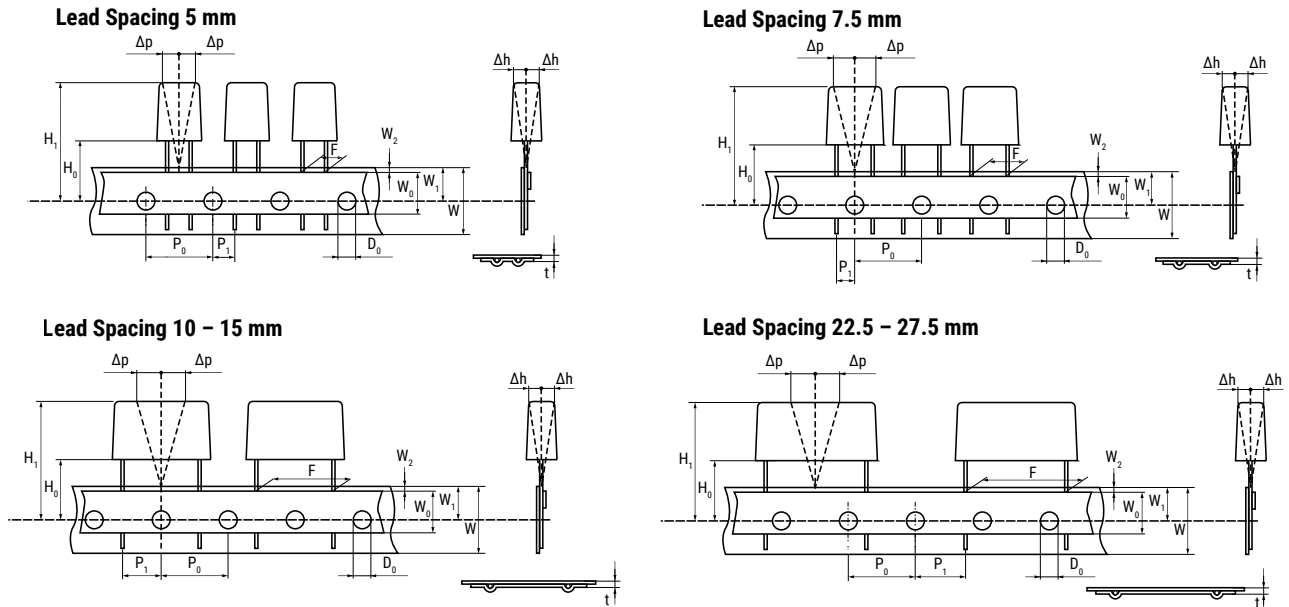

## Taping Specification

Dimensions in mm									Standard IEC 60286-2
Lead spacing	+6/-0.1	F	5	7.5	10	15	22.5	27.5	F
Carrier tape width	+1/-0.5	W	18	18	18	18	18	18	18 <sup>+1/-0.5</sup>
Hold-down tape width	Minimum	W <sub>0</sub>	6	6	9	10	10	10	
Position of sprocket hole	±0.5	W <sub>1</sub>	9	9	9	9	9	9	9 <sup>+0.75/-0.5</sup>
Distance between tapes	Maximum	W <sub>2</sub>	3	3	3	3	3	3	3
Sprocket hole diameter	±0.2	D <sub>0</sub>	4	4	4	4	4	4	4
Feed hole lead spacing	±0.2 <sup>(1)</sup>	P <sub>0</sub> <sup>(3)</sup>	12.7	12.7	12.7	12.7	12.7	12.7	12.7
Distance lead – feed hole	±0.7	P <sub>1</sub>	3.85	3.75	7.7	5.2	7.8	5.3	P <sup>1</sup>
Deviation tape – plane	Maximum	Δp	1.3	1.3	1.3	1.3	1.3	1.3	1.3
Lateral deviation	±2	Δh	2	2	2	2	2	2	2
Total thickness	±0.2	t	0.7	0.7	0.7	0.7	0.9 <sup>MAX</sup>	0.9 <sup>MAX</sup>	0.9 <sup>MAX</sup>
Sprocket hole/cap body	±0.5	H <sub>0</sub> <sup>(2)</sup>	18.5 <sup>±0.5</sup>	18.5 <sup>±0.5</sup>	18.5 <sup>±0.5</sup>	18.5 <sup>±0.5</sup>	18.5 <sup>±0.5</sup>	18.5 <sup>±0.5</sup>	18 <sup>+2/-0</sup>

(1) Maximum cumulative feed hole error, 1 mm per 20 parts.

(2) 16.5 mm available on request.

(3) 15 mm available on request (F ≥ 10 mm).

## Lead Taping & Packaging (IEC 60286-2) cont'd

### Ammo Specifications

Series	Dimensions (mm)		
	H	W	T
F5A, F5B, F5D	360	340	59
F6xx, F8xx			
PHExxx, PMExxx, PMRxxx	330	330	50

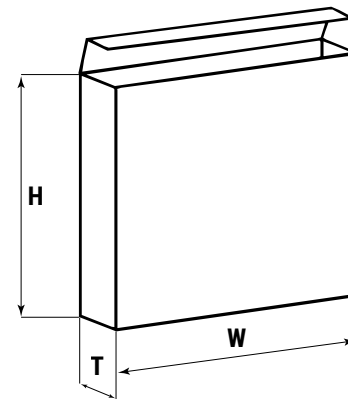

### Reel Specifications

Series	Dimensions (mm)		
	D	H	W
F5A, F5B, F5D	355	30	55
F6xx, F8xx	500	25	(Maximum)
PHExxx, PMExxx, PMRxxx	360	30	46 (Maximum)
	500		

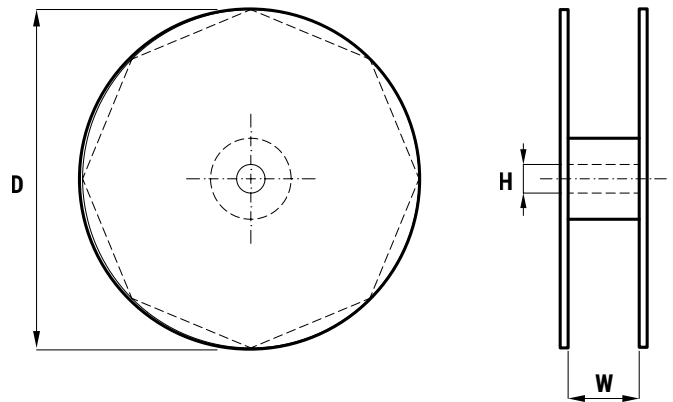

### Manufacturing Date Code (IEC-60062)

Y = Year, Z = Month			
Year	Code	Month	Code
2010	A	January	1
2011	B	February	2
2012	C	March	3
2013	D	April	4
2014	E	May	5
2015	F	June	6
2016	H	July	7
2017	J	August	8
2018	K	September	9
2019	L	October	0
2020	M	November	N
2021	N	December	D
2022	P		
2023	R		
2024	S		
2025	T		
2026	U		
2027	V		
2028	W		
2029	X		
2030	A		

## KEMET Electronics Corporation Sales Offices

For a complete list of our global sales offices, please visit [www.kemet.com/sales](http://www.kemet.com/sales).

---

### Disclaimer

All product specifications, statements, information and data (collectively, the "Information") in this datasheet are subject to change. The customer is responsible for checking and verifying the extent to which the Information contained in this publication is applicable to an order at the time the order is placed.

All Information given herein is believed to be accurate and reliable, but it is presented without guarantee, warranty, or responsibility of any kind, expressed or implied.

Statements of suitability for certain applications are based on KEMET Electronics Corporation's ("KEMET") knowledge of typical operating conditions for such applications, but are not intended to constitute – and KEMET specifically disclaims – any warranty concerning suitability for a specific customer application or use. The Information is intended for use only by customers who have the requisite experience and capability to determine the correct products for their application. Any technical advice inferred from this Information or otherwise provided by KEMET with reference to the use of KEMET's products is given gratis, and KEMET assumes no obligation or liability for the advice given or results obtained.

Although KEMET designs and manufactures its products to the most stringent quality and safety standards, given the current state of the art, isolated component failures may still occur. Accordingly, customer applications which require a high degree of reliability or safety should employ suitable designs or other safeguards (such as installation of protective circuitry or redundancies) in order to ensure that the failure of an electrical component does not result in a risk of personal injury or property damage.

Although all product-related warnings, cautions and notes must be observed, the customer should not assume that all safety measures are indicated or that other measures may not be required.

*KEMET is a registered trademark of KEMET Electronics Corporation.*



单击下面可查看定价，库存，交付和生命周期等信息

[>>KEMET Electronics\(基美\)](#)