

Ultra-low-power 32b MCU ARM[®]-based Cortex[®]-M3, 256KB Flash, 16KB SRAM, 4KB EEPROM, LCD, USB, ADC, DAC, memory I/F

Datasheet –production data

Features

- Ultra-low-power platform
 - 1.65 V to 3.6 V power supply
 - **-40 °C to 105 °C** temperature range
 - 0.29 µA Standby mode (3 wakeup pins)
 - **1.15 µA Standby mode + RTC**
 - 0.44 µA Stop mode (16 wakeup lines)
 - 1.4 µA Stop mode + RTC
 - 8.6 µA Low-power run mode
 - 185 µA/MHz Run mode
 - 10 nA ultra-low I/O leakage
 - 8 µs wakeup time
- Core: ARM[®] Cortex[®]-M3 32-bit CPU
 - From 32 kHz up to 32 MHz max
 - 1.25 DMIPS/MHz (Dhrystone 2.1)
 - Memory protection unit
- Reset and supply management
 - Low-power, ultrasafe BOR (brownout reset) with 5 selectable thresholds
 - Ultra-low-power POR/PDR
 - Programmable voltage detector (PVD)
- Clock sources
 - 1 to 24 MHz crystal oscillator
 - 32 kHz oscillator for RTC with calibration
 - High Speed Internal 16 MHz
 - Internal low-power 37 kHz RC
 - Internal multispeed low-power 65 kHz to 4.2 MHz
 - PLL for CPU clock and USB (48 MHz)
- Pre-programmed bootloader
 - USB and USART supported
- Development support
 - Serial wire debug supported
 - JTAG supported
- 51 fast I/Os (42 I/Os 5V tolerant), all mappable on 16 external interrupt vectors



- Memories
 - 256 Kbytes of Flash memory with ECC
 - 16 Kbytes of RAM
 - 4 Kbytes of true EEPROM with ECC
 - 20-byte backup register
- LCD Driver for up to 8x28 segments
- Analog peripherals
 - 12-bit ADC 1Msps up to 20 channels
 - 12-bit DACs 2 channels with output buffers
 - 2x ultra-low-power-comparators (window mode and wakeup capability)
- DMA controller 12x channels
- 9x peripheral communication interfaces
 - 1x USB 2.0 (internal 48 MHz PLL)
 - 3x USARTs
 - Up to 8x SPIs (2x I2Ss, 3x 16 Mbits/s)
 - 2x I2Cs (SMBus/PMBus)
- 10x timers: 6x 16-bit with up to 4 IC/OC/PWM channels, 2x 16-bit basic timers, 2x watchdog timers (independent and window)
- CRC calculation unit

Contents

- 1 Introduction 8**
- 2 Description 9**
 - 2.1 Device overview 10
 - 2.2 Ultra-low-power device continuum 10
 - 2.2.1 Performance 11
 - 2.2.2 Shared peripherals 11
 - 2.2.3 Common system strategy 11
 - 2.2.4 Features 11
- 3 Functional overview 12**
 - 3.1 Low-power modes 13
 - 3.2 ARM[®] Cortex[®]-M3 core with MPU 17
 - 3.3 Reset and supply management 18
 - 3.3.1 Power supply schemes 18
 - 3.3.2 Power supply supervisor 18
 - 3.3.3 Voltage regulator 19
 - 3.3.4 Boot modes 19
 - 3.4 Clock management 20
 - 3.5 Low-power real-time clock and backup registers 22
 - 3.6 GPIOs (general-purpose inputs/outputs) 22
 - 3.7 Memories 23
 - 3.8 DMA (direct memory access) 23
 - 3.9 LCD (liquid crystal display) 24
 - 3.10 ADC (analog-to-digital converter) 24
 - 3.10.1 Internal voltage reference (V_{REFINT}) 24
 - 3.11 DAC (digital-to-analog converter) 25
 - 3.12 Ultra-low-power comparators and reference voltage 25
 - 3.13 System configuration controller and routing interface 25
 - 3.14 Timers and watchdogs 26
 - 3.14.1 General-purpose timers (TIM2, TIM3, TIM4, TIM9, TIM10 and TIM11) 26
 - 3.14.2 Basic timers (TIM6 and TIM7) 27



| | | |
|----------|---|-----------|
| 3.14.3 | SysTick timer | 27 |
| 3.14.4 | Independent watchdog (IWDG) | 27 |
| 3.14.5 | Window watchdog (WWDG) | 27 |
| 3.15 | Communication interfaces | 27 |
| 3.15.1 | I ² C bus | 27 |
| 3.15.2 | Universal synchronous/asynchronous receiver transmitter (USART) | 27 |
| 3.15.3 | Serial peripheral interface (SPI) | 28 |
| 3.15.4 | Universal serial bus (USB) | 28 |
| 3.16 | CRC (cyclic redundancy check) calculation unit | 28 |
| 3.17 | Development support | 29 |
| 3.17.1 | Serial wire JTAG debug port (SWJ-DP) | 29 |
| 3.17.2 | Embedded Trace Macrocell™ | 29 |
| 4 | Pin descriptions | 30 |
| 5 | Memory mapping | 40 |
| 6 | Electrical characteristics | 41 |
| 6.1 | Parameter conditions | 41 |
| 6.1.1 | Minimum and maximum values | 41 |
| 6.1.2 | Typical values | 41 |
| 6.1.3 | Typical curves | 41 |
| 6.1.4 | Loading capacitor | 41 |
| 6.1.5 | Pin input voltage | 41 |
| 6.1.6 | Power supply scheme | 42 |
| 6.1.7 | Optional LCD power supply scheme | 43 |
| 6.1.8 | Current consumption measurement | 43 |
| 6.2 | Absolute maximum ratings | 44 |
| 6.3 | Operating conditions | 45 |
| 6.3.1 | General operating conditions | 45 |
| 6.3.2 | Embedded reset and power control block characteristics | 46 |
| 6.3.3 | Embedded internal reference voltage | 48 |
| 6.3.4 | Supply current characteristics | 49 |
| 6.3.5 | Wakeup time from low-power mode | 60 |
| 6.3.6 | External clock source characteristics | 61 |
| 6.3.7 | Internal clock source characteristics | 66 |
| 6.3.8 | PLL characteristics | 69 |



| | | |
|----------|--|------------|
| 6.3.9 | Memory characteristics | 69 |
| 6.3.10 | EMC characteristics | 71 |
| 6.3.11 | Electrical sensitivity characteristics | 72 |
| 6.3.12 | I/O current injection characteristics | 73 |
| 6.3.13 | I/O port characteristics | 74 |
| 6.3.14 | NRST pin characteristics | 77 |
| 6.3.15 | TIM timer characteristics | 78 |
| 6.3.16 | Communications interfaces | 79 |
| 6.3.17 | 12-bit ADC characteristics | 87 |
| 6.3.18 | DAC electrical specifications | 92 |
| 6.3.19 | Operational amplifier characteristics | 94 |
| 6.3.20 | Comparator | 96 |
| 6.3.21 | LCD controller | 97 |
| 7 | Package information | 98 |
| 7.1 | LQFP64, 10 x 10 mm, 64-pin low-profile quad flat package information | 98 |
| 7.2 | Thermal characteristics | 101 |
| 7.2.1 | Reference document | 102 |
| 8 | Ordering information | 103 |
| 9 | Revision history | 104 |

List of tables

| | | |
|-----------|---|----|
| Table 1. | Ultra-low-power STM32L100RC device features and peripheral counts | 10 |
| Table 2. | Functionalities depending on the operating power supply range | 14 |
| Table 3. | CPU frequency range depending on dynamic voltage scaling | 15 |
| Table 4. | Functionalities depending on the working mode (from Run/active down to standby) | 16 |
| Table 5. | Timer feature comparison | 26 |
| Table 6. | Legend/abbreviations used in the pinout table | 31 |
| Table 7. | STM32L100RC pin definitions | 31 |
| Table 8. | Alternate function input/output | 36 |
| Table 9. | Voltage characteristics | 44 |
| Table 10. | Current characteristics | 44 |
| Table 11. | Thermal characteristics | 45 |
| Table 12. | General operating conditions | 45 |
| Table 13. | Embedded reset and power control block characteristics | 46 |
| Table 14. | Embedded internal reference voltage calibration values | 48 |
| Table 15. | Embedded internal reference voltage | 48 |
| Table 16. | Current consumption in Run mode, code with data processing running from Flash. | 50 |
| Table 17. | Current consumption in Run mode, code with data processing running from RAM | 51 |
| Table 18. | Current consumption in Sleep mode | 52 |
| Table 19. | Current consumption in Low-power run mode | 53 |
| Table 20. | Current consumption in Low-power sleep mode | 54 |
| Table 21. | Typical and maximum current consumptions in Stop mode | 55 |
| Table 22. | Typical and maximum current consumptions in Standby mode | 57 |
| Table 23. | Peripheral current consumption | 58 |
| Table 24. | Low-power mode wakeup timings | 60 |
| Table 25. | High-speed external user clock characteristics | 61 |
| Table 26. | Low-speed external user clock characteristics | 62 |
| Table 27. | HSE oscillator characteristics | 63 |
| Table 28. | LSE oscillator characteristics ($f_{LSE} = 32.768$ kHz) | 64 |
| Table 29. | HSI oscillator characteristics | 66 |
| Table 30. | LSI oscillator characteristics | 66 |
| Table 31. | MSI oscillator characteristics | 67 |
| Table 32. | PLL characteristics | 69 |
| Table 33. | RAM and hardware registers | 69 |
| Table 34. | Flash memory and data EEPROM characteristics | 70 |
| Table 35. | Flash memory and data EEPROM endurance and retention | 70 |
| Table 36. | EMS characteristics | 71 |
| Table 37. | EMI characteristics | 72 |
| Table 38. | ESD absolute maximum ratings | 72 |
| Table 39. | Electrical sensitivities | 73 |
| Table 40. | I/O current injection susceptibility | 73 |
| Table 41. | I/O static characteristics | 74 |
| Table 42. | Output voltage characteristics | 75 |
| Table 43. | I/O AC characteristics | 76 |
| Table 44. | NRST pin characteristics | 77 |
| Table 45. | TIMx characteristics | 78 |
| Table 46. | I ² C characteristics | 79 |
| Table 47. | SCL frequency ($f_{PCLK1} = 32$ MHz, $V_{DD} = V_{DD_I2C} = 3.3$ V) | 80 |

| | | |
|-----------|---|-----|
| Table 48. | SPI characteristics | 81 |
| Table 49. | USB startup time | 84 |
| Table 50. | USB DC electrical characteristics | 84 |
| Table 51. | USB: full speed electrical characteristics | 84 |
| Table 52. | I2S characteristics | 85 |
| Table 53. | ADC clock frequency | 87 |
| Table 54. | ADC characteristics | 87 |
| Table 55. | ADC accuracy | 89 |
| Table 56. | Maximum source impedance $R_{AIN\ max}$ | 91 |
| Table 57. | DAC characteristics | 92 |
| Table 58. | Operational amplifier characteristics | 94 |
| Table 59. | Comparator 1 characteristics | 96 |
| Table 60. | Comparator 2 characteristics | 96 |
| Table 61. | LCD controller characteristics | 97 |
| Table 62. | LQFP64, 10 x 10 mm 64-pin low-profile quad flat package mechanical data | 99 |
| Table 63. | Thermal characteristics | 101 |
| Table 64. | STM32L100RC ordering information scheme | 103 |
| Table 65. | Document revision history | 104 |

List of figures

| | | |
|------------|--|-----|
| Figure 1. | Ultra-low-power STM32L100RC block diagram | 12 |
| Figure 2. | Clock tree | 21 |
| Figure 3. | STM32L100RC LQFP64 pinout | 30 |
| Figure 4. | Memory map | 40 |
| Figure 5. | Pin loading conditions | 41 |
| Figure 6. | Pin input voltage | 41 |
| Figure 7. | Power supply scheme | 42 |
| Figure 8. | Optional LCD power supply scheme | 43 |
| Figure 9. | Current consumption measurement scheme | 43 |
| Figure 10. | High-speed external clock source AC timing diagram | 61 |
| Figure 11. | Low-speed external clock source AC timing diagram | 62 |
| Figure 12. | HSE oscillator circuit diagram | 64 |
| Figure 13. | Typical application with a 32.768 kHz crystal | 65 |
| Figure 14. | I/O AC characteristics definition | 77 |
| Figure 15. | Recommended NRST pin protection | 78 |
| Figure 16. | I ² C bus AC waveforms and measurement circuit | 80 |
| Figure 17. | SPI timing diagram - slave mode and CPHA = 0 | 82 |
| Figure 18. | SPI timing diagram - slave mode and CPHA = 1 ⁽¹⁾ | 82 |
| Figure 19. | SPI timing diagram - master mode ⁽¹⁾ | 83 |
| Figure 20. | USB timings: definition of data signal rise and fall time | 84 |
| Figure 21. | I ² S slave timing diagram (Philips protocol) ⁽¹⁾ | 86 |
| Figure 22. | I ² S master timing diagram (Philips protocol) ⁽¹⁾ | 86 |
| Figure 23. | ADC accuracy characteristics | 90 |
| Figure 24. | Typical connection diagram using the ADC | 90 |
| Figure 25. | Maximum dynamic current consumption on V _{REF+} supply pin during ADC conversion | 91 |
| Figure 26. | 12-bit buffered /non-buffered DAC | 94 |
| Figure 27. | LQFP64, 10 x 10 mm, 64-pin low-profile quad flat package outline | 98 |
| Figure 28. | LQFP64 Recommended footprint | 99 |
| Figure 29. | LQFP64 device marking example | 100 |
| Figure 30. | Thermal resistance suffix 6 | 101 |
| Figure 31. | Thermal resistance suffix 7 | 102 |

1 Introduction

This datasheet provides the ordering information and mechanical device characteristics of the STM32L100RC ultra-low-power ARM[®] Cortex[®]-M3 based microcontroller product line.

The ultra-low-power STM32L100RC device is a microcontroller of 256 Kbytes in a 64-pin package, the description below gives an overview of the complete range of peripherals proposed in this device.

These features make the ultra-low-power STM32L100RC microcontroller suitable for a wide range of applications:

- Medical and handheld equipment
- Application control and user interface
- PC peripherals, gaming, GPS and sport equipment
- Alarm systems, wired and wireless sensors, video intercom
- Utility metering

This STM32L100RC datasheet should be read in conjunction with the STM32L1xxxx reference manual (RM0038). The application note “Getting started with STM32L1xxxx hardware development” (AN3216) gives a hardware implementation overview. Both documents are available from the STMicroelectronics website www.st.com.

For information on the ARM[®] Cortex[®]-M3 core please refer to the ARM[®] Cortex[®]-M3 technical reference manual, available from the www.arm.com website. *Figure 1* shows the general block diagram of the device.

2 Description

The ultra-low-power STM32L100RC device incorporates the connectivity power of the universal serial bus (USB) with the high-performance ARM[®] Cortex[®]-M3 32-bit RISC core operating at a frequency of 32 MHz (33.3 DMIPS), a memory protection unit (MPU), high-speed embedded memories (Flash memory up to 256 Kbytes and RAM up to 16 Kbytes) and an extensive range of enhanced I/Os and peripherals connected to two APB buses.

The STM32L100RC device offers one 12-bit ADC, two DACs, two ultra-low-power comparators, six general-purpose 16-bit timers and two basic timers, which can be used as time bases.

Moreover, the STM32L100RC device contains standard and advanced communication interfaces: up to two I2Cs, three SPIs, two I2Ss, three USARTs, and an USB.

It also includes a real-time clock and a set of backup registers that remain powered in Standby mode.

Finally, the integrated LCD controller has a built-in LCD voltage generator that allows to drive up to 8 multiplexed LCDs with the contrast independent of the supply voltage.

The ultra-low-power STM32L100RC device operates from a 1.8 to 3.6 V power supply (down to 1.65 V at power down) with BOR and from a 1.65 to 3.6 V power supply without BOR option. It is available in the -40 to +85 °C and -40 to +105 °C temperature ranges. A comprehensive set of power-saving modes allows the design of low-power applications.



2.1 Device overview

Table 1. Ultra-low-power STM32L100RC device features and peripheral counts

| Peripheral | | STM32L100RC |
|---|------------------|--|
| Flash (Kbytes) | | 256 |
| Data EEPROM (Kbytes) | | 4 |
| RAM (Kbytes) | | 16 |
| 16-bit Timers | General-purpose | 6 |
| | Basic | 2 |
| Communication interfaces | SPI | 8(3) ⁽¹⁾ |
| | I ² S | 2 |
| | I ² C | 2 |
| | USART | 3 |
| | USB | 1 |
| GPIOs | | 51 |
| 12-bit synchronized ADC Number of channels | | 1 20 |
| 12-bit DAC Number total of channels | | 2 2 |
| LCD COM x SEG | | 4x32 or 8x28 |
| Comparators | | 2 |
| Max. CPU frequency | | 32 MHz |
| Operating voltage | | 1.8 V to 3.6 V |
| Operating temperatures | | Ambient operating temperature: -40 °C to 85 °C / -40 °C to 105 °C Junction temperature: -40 to + 110 °C |
| Package | | LQFP64 |

1. 5 SPIs are USART configured in synchronous mode emulating SPI master.

2.2 Ultra-low-power device continuum

The ultra-low-power family offers a large choice of cores and features. From proprietary 8-bit to up to Cortex-M3, including the Cortex-M0+, the STM32Lx series are the best choice to answer the user needs, in terms of ultra-low-power features. The STM32 ultra-low-power series are the best fit, for instance, for gas/water meter, keyboard/mouse or fitness and healthcare, wearable applications. Several built-in features like LCD drivers, dual-bank

memory, Low-power run mode, op-amp, AES 128-bit, DAC, USB crystal-less and many others will clearly allow to build very cost-optimized applications by reducing BOM.

Note: STMicroelectronics as a reliable and long-term manufacturer ensures as much as possible the pin-to-pin compatibility between any STM8Lxxxx and STM32Lxxxx devices and between any of the STM32Lx and STM32Fx series. Thanks to this unprecedented scalability, the old applications can be upgraded to respond to the latest market features and efficiency demand.

2.2.1 Performance

All the families incorporate highly energy-efficient cores with both Harvard architecture and pipelined execution: advanced STM8 core for STM8L families and ARM Cortex-M3 core for STM32L family. In addition specific care for the design architecture has been taken to optimize the mA/DMIPS and mA/MHz ratios.

This allows the ultra-low-power performance to range from 5 up to 33.3 DMIPs.

2.2.2 Shared peripherals

STM8L15xxx, STM32L15xxx and STM32L162xx share identical peripherals which ensure a very easy migration from one family to another:

- Analog peripherals: ADC, DAC and comparators
- Digital peripherals: RTC and some communication interfaces

2.2.3 Common system strategy.

To offer flexibility and optimize performance, the STM8L15xxx, STM32L15xxx and STM32L162xx family uses a common architecture:

- Same power supply range from 1.65 V to 3.6 V
- Architecture optimized to reach ultra-low consumption both in low-power modes and Run mode
- Fast startup strategy from low-power modes
- Flexible system clock
- Ultrasafe reset: same reset strategy including power-on reset, power-down reset, brownout reset and programmable voltage detector

2.2.4 Features

ST ultra-low-power continuum also lies in feature compatibility:

- More than 15 packages with pin count from 20 to 144 pins and size down to 3 x 3 mm
- Memory density ranging from 2 to 512 Kbytes

3 Functional overview

Figure 1. Ultra-low-power STM32L100RC block diagram

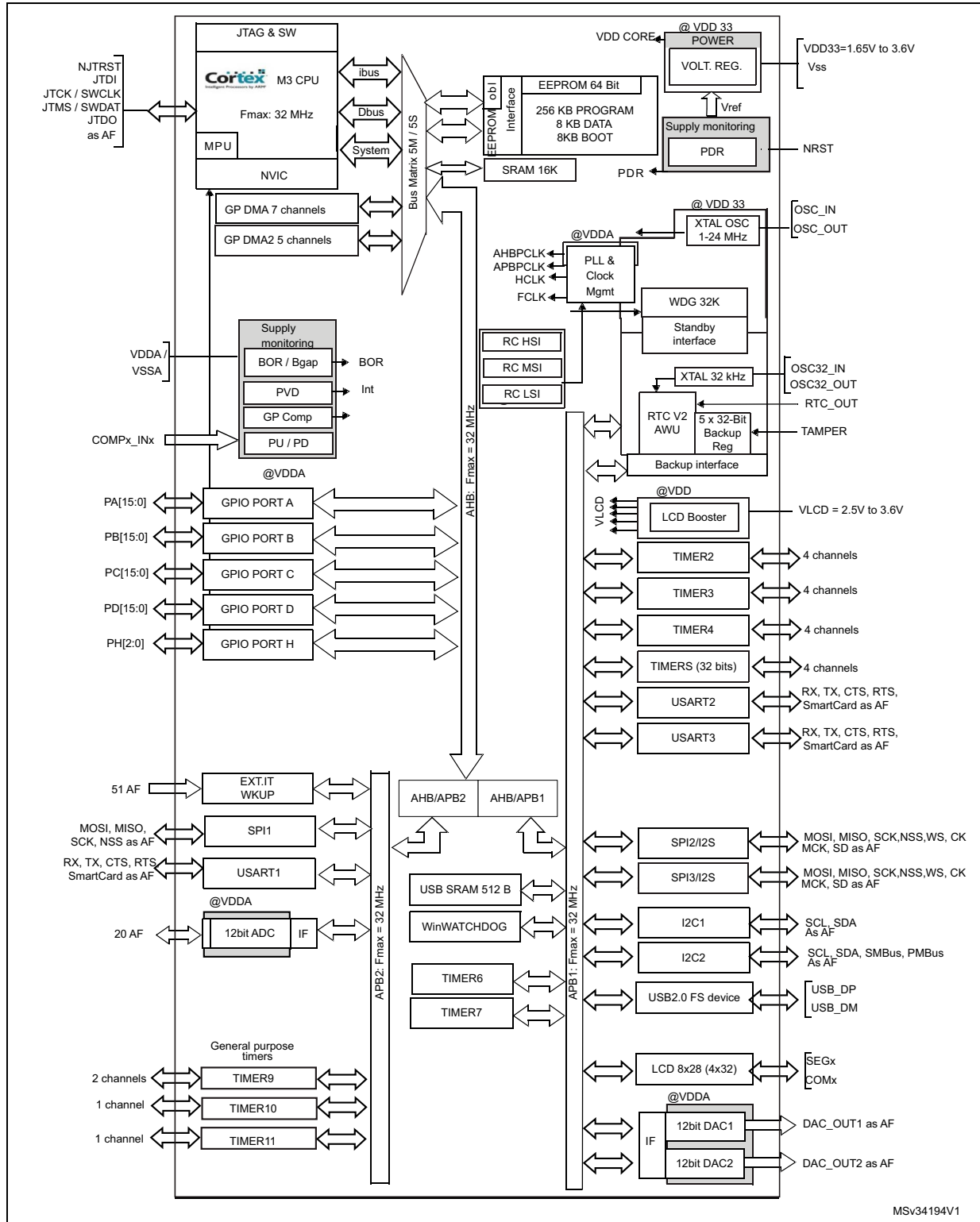

MSv34194V1



3.1 Low-power modes

The ultra-low-power STM32L100RC device supports dynamic voltage scaling to optimize its power consumption in run mode. The voltage from the internal low-drop regulator that supplies the logic can be adjusted according to the system's maximum operating frequency and the external voltage supply.

There are three power consumption ranges:

- Range 1 (V_{DD} range limited to 2.0 V - 3.6 V), with the CPU running at up to 32 MHz
- Range 2 (full V_{DD} range), with a maximum CPU frequency of 16 MHz
- Range 3 (full V_{DD} range), with a maximum CPU frequency limited to 4 MHz (generated only with the multispeed internal RC oscillator clock source)

Seven low-power modes are provided to achieve the best compromise between low-power consumption, short startup time and available wakeup sources:

- **Sleep mode**
In Sleep mode, only the CPU is stopped. All peripherals continue to operate and can wake up the CPU when an interrupt/event occurs. Sleep mode power consumption at 16 MHz is about 1 mA with all peripherals off.
- **Low-power run mode**
This mode is achieved with the multispeed internal (MSI) RC oscillator set to the MSI range 0 or MSI range 1 clock range (maximum 131 kHz), execution from SRAM or Flash memory, and internal regulator in low-power mode to minimize the regulator's operating current. In low-power run mode, the clock frequency and the number of enabled peripherals are both limited.
- **Low-power sleep mode**
This mode is achieved by entering Sleep mode with the internal voltage regulator in Low-power mode to minimize the regulator's operating current. In Low-power sleep mode, both the clock frequency and the number of enabled peripherals are limited; a typical example would be to have a timer running at 32 kHz.
When wakeup is triggered by an event or an interrupt, the system reverts to the run mode with the regulator on.
- **Stop mode with RTC**
Stop mode achieves the lowest power consumption while retaining the RAM and register contents and real time clock. All clocks in the V_{CORE} domain are stopped, the PLL, MSI RC, HSI RC and HSE crystal oscillators are disabled. The LSE or LSI is still running. The voltage regulator is in the low-power mode.
The device can be woken up from Stop mode by any of the EXTI line, in 8 μ s. The EXTI line source can be one of the 16 external lines. It can be the PVD output, the Comparator 1 event or Comparator 2 event (if internal reference voltage is on), it can be the RTC alarm(s), the USB wakeup, the RTC tamper events, the RTC timestamp event or the RTC wakeup.

- Stop mode without RTC**

Stop mode achieves the lowest power consumption while retaining the RAM and register contents. All clocks are stopped, the PLL, MSI RC, HSI and LSI RC, LSE and HSE crystal oscillators are disabled. The voltage regulator is in the low-power mode. The device can be woken up from Stop mode by any of the EXTI line, in 8 μ s. The EXTI line source can be one of the 16 external lines. It can be the PVD output, the Comparator 1 event or Comparator 2 event (if internal reference voltage is on). It can also be wakened by the USB wakeup.
- Standby mode with RTC**

Standby mode is used to achieve the lowest power consumption and real time clock. The internal voltage regulator is switched off so that the entire V_{CORE} domain is powered off. The PLL, MSI RC, HSI RC and HSE crystal oscillators are also switched off. The LSE or LSI is still running. After entering Standby mode, the RAM and register contents are lost except for registers in the Standby circuitry (wakeup logic, IWDG, RTC, LSI, LSE Crystal 32K osc, RCC_CSR).

The device exits Standby mode in 60 μ s when an external reset (NRST pin), an IWDG reset, a rising edge on one of the three WKUP pins, RTC alarm (Alarm A or Alarm B), RTC tamper event, RTC timestamp event or RTC Wakeup event occurs.
- Standby mode without RTC**

Standby mode is used to achieve the lowest power consumption. The internal voltage regulator is switched off so that the entire V_{CORE} domain is powered off. The PLL, MSI RC, HSI and LSI RC, HSE and LSE crystal oscillators are also switched off. After entering Standby mode, the RAM and register contents are lost except for registers in the Standby circuitry (wakeup logic, IWDG, RTC, LSI, LSE Crystal 32K osc, RCC_CSR).

The device exits Standby mode in 60 μ s when an external reset (NRST pin) or a rising edge on one of the three WKUP pin occurs.

Note: The RTC, the IWDG, and the corresponding clock sources are not stopped automatically by entering Stop or Standby mode.

Table 2. Functionalities depending on the operating power supply range

| Operating power supply range | Functionalities depending on the operating power supply range ⁽¹⁾ | | |
|------------------------------|--|---------------------------|-------------------------------|
| | DAC and ADC operation | USB | Dynamic voltage scaling range |
| $V_{DD} = 1.8$ to 2.0 V | Conversion time up to 500 Ksps | Not functional | Range 2 or range 3 |
| $V_{DD} = 2.0$ to 2.4 V | Conversion time up to 500 Ksps | Functional ⁽²⁾ | Range 1, range 2 or range 3 |
| $V_{DD} = 2.4$ to 3.6 V | Conversion time up to 1 Msps | Functional ⁽²⁾ | Range 1, range 2 or range 3 |

1. The GPIO speed also depends from VDD voltage and the user has to refer to [Table 43: I/O AC characteristics](#) for more information about I/O speed.

2. To be USB compliant from the IO voltage standpoint, the minimum V_{DD} is 3.0 V.



Table 3. CPU frequency range depending on dynamic voltage scaling

| CPU frequency range | Dynamic voltage scaling range |
|--|-------------------------------|
| 16 MHz to 32 MHz (1ws) 32 kHz to 16 MHz (0ws) | Range 1 |
| 8 MHz to 16 MHz (1ws) 32 kHz to 8 MHz (0ws) | Range 2 |
| 2.1MHz to 4.2 MHz (1ws) 32 kHz to 2.1 MHz (0ws) | Range 3 |

Table 4. Functionalities depending on the working mode (from Run/active down to standby)

| Ips | Run/Active | Sleep | Low-power Run | Low-power Sleep | Stop | | Standby | |
|-------------------------------------|------------|-------|---------------|-----------------|-------------------|-------------------|---------|----|
| | | | | | Wakeup capability | Wakeup capability | | |
| CPU | Y | -- | Y | -- | -- | -- | -- | -- |
| Flash | Y | Y | Y | Y | -- | -- | -- | -- |
| RAM | Y | Y | Y | Y | Y | -- | -- | -- |
| Backup Registers | Y | Y | Y | Y | Y | -- | Y | -- |
| EEPROM | Y | Y | Y | Y | Y | -- | -- | -- |
| Brown-out rest (BOR) | Y | Y | Y | Y | Y | Y | Y | -- |
| DMA | Y | Y | Y | Y | -- | -- | -- | -- |
| Programmable Voltage Detector (PVD) | Y | Y | Y | Y | Y | Y | Y | -- |
| Power On Reset (POR) | Y | Y | Y | Y | Y | Y | Y | -- |
| Power Down Rest (PDR) | Y | Y | Y | Y | Y | -- | Y | -- |
| High Speed Internal (HSI) | Y | Y | -- | -- | -- | -- | -- | -- |
| High Speed External (HSE) | Y | Y | -- | -- | -- | -- | -- | -- |
| Low Speed Internal (LSI) | Y | Y | Y | Y | Y | -- | Y | -- |
| Low Speed External (LSE) | Y | Y | Y | Y | Y | -- | Y | -- |
| Multi-Speed Internal (MSI) | Y | Y | Y | Y | -- | -- | -- | -- |
| Inter-Connect Controller | Y | Y | Y | Y | -- | -- | -- | -- |
| RTC | Y | Y | Y | Y | Y | Y | Y | -- |
| RTC Tamper | Y | Y | Y | Y | Y | Y | Y | Y |
| Auto WakeUp (AWU) | Y | Y | Y | Y | Y | Y | Y | Y |
| LCD | Y | Y | Y | Y | Y | -- | -- | -- |
| USB | Y | Y | -- | -- | -- | Y | -- | -- |
| USART | Y | Y | Y | Y | Y | (1) | -- | -- |
| SPI | Y | Y | Y | Y | -- | -- | -- | -- |
| I2C | Y | Y | -- | -- | -- | (1) | -- | -- |



Table 4. Functionalities depending on the working mode (from Run/active down to standby) (continued)

| Ips | Run/Active | Sleep | Low-power Run | Low-power Sleep | Stop | | Standby | |
|--|---------------------------------|----------------------------------|----------------|-----------------|---|-------------------|---|--------|
| | | | | | Wakeup capability | Wakeup capability | | |
| ADC | Y | Y | -- | -- | -- | -- | -- | -- |
| DAC | Y | Y | Y | Y | Y | -- | -- | -- |
| Tempsensor | Y | Y | Y | Y | Y | -- | -- | -- |
| OP amp | Y | Y | Y | Y | Y | -- | -- | -- |
| Comparators | Y | Y | Y | Y | Y | Y | -- | -- |
| 16-bit and 32-bit Timers | Y | Y | Y | Y | -- | -- | -- | -- |
| IWDG | Y | Y | Y | Y | Y | Y | Y | Y |
| WWDG | Y | Y | Y | Y | -- | -- | -- | -- |
| Touch sensing | Y | Y | -- | -- | -- | -- | -- | -- |
| Systic Timer | Y | Y | Y | Y | | -- | -- | -- |
| GPIOs | Y | Y | Y | Y | Y | Y | -- | 3 pins |
| Wakeup time to Run mode | 0 μs | 0.4 μs | 3 μs | 46 μs | < 8 μs | | 58 μs | |
| Consumption V _{DD} =1.8 to 3.6 V (Typ) | Down to 185 μA/MHz (from Flash) | Down to 34.5 μA/MHz (from Flash) | Down to 8.6 μA | Down to 4.4 μA | 0.43 μA (no RTC) V _{DD} =1.8V | | 0.29 μA (no RTC) V _{DD} =1.8V | |
| | | | | | 1.15 μA (with RTC) V _{DD} =1.8V | | 0.9 μA (with RTC) V _{DD} =1.8V | |
| | | | | | 0.44 μA (no RTC) V _{DD} =3.0V | | 0.29 μA (no RTC) V _{DD} =3.0V | |
| | | | | | 1.4 μA (with RTC) V _{DD} =3.0V | | 1.15 μA (with RTC) V _{DD} =3.0V | |

1. The startup on communication line wakes the CPU which was made possible by an EXTI, this induces a delay before entering run mode.

3.2 ARM[®] Cortex[®]-M3 core with MPU

The ARM[®] Cortex[®]-M3 processor is the industry leading processor for embedded systems. It has been developed to provide a low-cost platform that meets the needs of MCU implementation, with a reduced pin count and low-power consumption, while delivering outstanding computational performance and an advanced system response to interrupts.

The ARM[®] Cortex[®]-M3 32-bit RISC processor features exceptional code-efficiency, delivering the high-performance expected from an ARM core in the memory size usually associated with 8- and 16-bit device.



The memory protection unit (MPU) improves system reliability by defining the memory attributes (such as read/write access permissions) for different memory regions. It provides up to eight different regions and an optional predefined background region.

Owing to its embedded ARM core, the STM32L100RC device is compatible with all ARM tools and software.

Nested vectored interrupt controller (NVIC)

The ultra-low-power STM32L100RC device embeds a nested vectored interrupt controller able to handle up to 52 maskable interrupt channels (not including the 16 interrupt lines of ARM® Cortex®-M3) and 16 priority levels.

- Closely coupled NVIC gives low-latency interrupt processing
- Interrupt entry vector table address passed directly to the core
- Closely coupled NVIC core interface
- Allows early processing of interrupts
- Processing of *late arriving*, higher-priority interrupts
- Support for tail-chaining
- Processor state automatically saved on interrupt entry, and restored on interrupt exit, with no instruction overhead

This hardware block provides flexible interrupt management features with minimal interrupt latency.

3.3 Reset and supply management

3.3.1 Power supply schemes

- $V_{DD} = 1.65$ to 3.6 V: external power supply for I/Os and the internal regulator. Provided externally through V_{DD} pins.
- V_{SSA} , $V_{DDA} = 1.65$ to 3.6 V: external analog power supplies for ADC, reset blocks, RCs and PLL (minimum voltage to be applied to V_{DDA} is 1.8 V when the ADC is used). V_{DDA} and V_{SSA} must be connected to V_{DD} and V_{SS} , respectively.

3.3.2 Power supply supervisor

The device has an integrated ZEROPOWER power-on reset (POR)/power-down reset (PDR) that can be coupled with a brownout reset (BOR) circuitry.

The device exists in two versions:

- The version with BOR activated at power-on operates between 1.8 V and 3.6 V.
- The other version without BOR operates between 1.65 V and 3.6 V.

After the V_{DD} threshold is reached (1.65 V or 1.8 V depending on the BOR which is active or not at power-on), the option byte loading process starts, either to confirm or modify default thresholds, or to disable the BOR permanently: in this case, the V_{DD} min value becomes 1.65 V (whatever the version, BOR active or not, at power-on).

When BOR is active at power-on, it ensures proper operation starting from 1.8 V whatever the power ramp-up phase before it reaches 1.8 V. When BOR is not active at power-up, the power ramp-up should guarantee that 1.65 V is reached on V_{DD} at least 1 ms after it exits the POR area.

Five BOR thresholds are available through option bytes, starting from 1.8 V to 3 V. To reduce the power consumption in Stop mode, it is possible to automatically switch off the internal reference voltage (V_{REFINT}) in Stop mode. The device remains in reset mode when V_{DD} is below a specified threshold, $V_{POR/PDR}$ or V_{BOR} , without the need for any external reset circuit.

Note: The start-up time at power-on is typically 3.3 ms when BOR is active at power-up, the start-up time at power-on can be decreased down to 1 ms typically for a device with BOR inactive at power-up.

The device features an embedded programmable voltage detector (PVD) that monitors the V_{DD}/V_{DDA} power supply and compares it to the V_{PVD} threshold. This PVD offers 7 different levels between 1.85 V and 3.05 V, chosen by software, with a step around 200 mV. An interrupt can be generated when V_{DD}/V_{DDA} drops below the V_{PVD} threshold and/or when V_{DD}/V_{DDA} is higher than the V_{PVD} threshold. The interrupt service routine can then generate a warning message and/or put the MCU into a safe state. The PVD is enabled by software.

3.3.3 Voltage regulator

The regulator has three operation modes: main (MR), low-power (LPR) and power down.

- MR is used in Run mode (nominal regulation)
- LPR is used in the Low-power run, Low-power sleep and Stop modes
- Power down is used in Standby mode. The regulator output is high impedance, the kernel circuitry is powered down, inducing zero consumption but the contents of the registers and RAM are lost except for the standby circuitry (wake-up logic, IWDG, RTC, LSI, LSE crystal 32K osc, RCC_CSR).

3.3.4 Boot modes

At startup, boot pins are used to select one of three boot options:

- Boot from Flash memory
- Boot from System memory
- Boot from embedded RAM

The boot loader is located in System memory. It is used to reprogram the Flash memory by using USART1 and USART2. See Application note “STM32 microcontroller system memory boot mode” (AN2606) for details.

3.4 Clock management

The clock controller distributes the clocks coming from different oscillators to the core and the peripherals. It also manages clock gating for low-power modes and ensures clock robustness. It features:

- **Clock prescaler:** to get the best trade-off between speed and current consumption, the clock frequency to the CPU and peripherals can be adjusted by a programmable prescaler.
- **Safe clock switching:** clock sources can be changed safely on the fly in run mode through a configuration register.
- **Clock management:** to reduce power consumption, the clock controller can stop the clock to the core, individual peripherals or memory.
- **System clock source:** three different clock sources can be used to drive the master clock SYSCLK:
 - 1-24 MHz high-speed external crystal (HSE), that can supply a PLL
 - 16 MHz high-speed internal RC oscillator (HSI), trimmable by software, that can supply a PLL
 - Multispeed internal RC oscillator (MSI), trimmable by software, able to generate 7 frequencies (65 kHz, 131 kHz, 262 kHz, 524 kHz, 1.05 MHz, 2.1 MHz, 4.2 MHz). When a 32.768 kHz clock source is available in the system (LSE), the MSI frequency can be trimmed by software down to a $\pm 0.5\%$ accuracy.
- **Auxiliary clock source:** two ultra-low-power clock sources that can be used to drive the LCD controller and the real-time clock:
 - 32.768 kHz low-speed external crystal (LSE)
 - 37 kHz low-speed internal RC (LSI), also used to drive the independent watchdog. The LSI clock can be measured using the high-speed internal RC oscillator for greater precision.
- **RTC and LCD clock sources:** the LSI, LSE or HSE sources can be chosen to clock the RTC and the LCD, whatever the system clock.
- **USB clock source:** the embedded PLL has a dedicated 48 MHz clock output to supply the USB interface.
- **Startup clock:** after reset, the microcontroller restarts by default with an internal 2 MHz clock (MSI). The prescaler ratio and clock source can be changed by the application program as soon as the code execution starts.
- **Clock security system (CSS):** this feature can be enabled by software. If a HSE clock failure occurs, the master clock is automatically switched to HSI and a software interrupt is generated if enabled.
- **Clock-out capability (MCO: microcontroller clock output):** it outputs one of the internal clocks for external use by the application.

Several prescalers allow the configuration of the AHB frequency, each APB (APB1 and APB2) domains. The maximum frequency of the AHB and the APB domains is 32 MHz. See [Figure 2](#) for details on the clock tree.

Figure 2. Clock tree

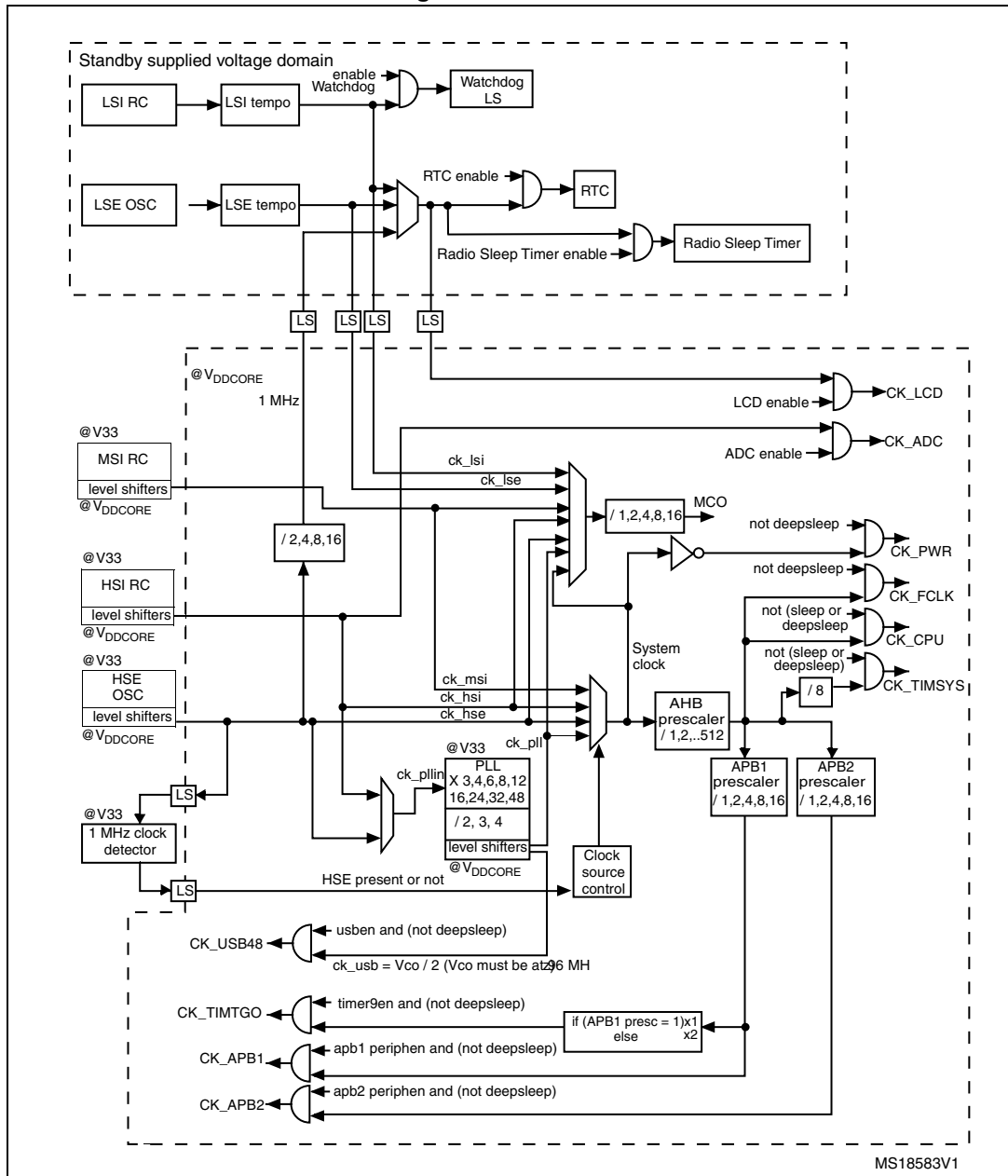

3.5 Low-power real-time clock and backup registers

The real-time clock (RTC) is an independent BCD timer/counter. Dedicated registers contain the sub-second, second, minute, hour (12/24 hour), week day, date, month, year, in BCD (binary-coded decimal) format. Correction for 28, 29 (leap year), 30, and 31 day of the month are made automatically. The RTC provides two programmable alarms and programmable periodic interrupts with wakeup from Stop and Standby modes.

The programmable wakeup time ranges from 120 μ s to 36 hours.

The RTC can be calibrated with an external 512 Hz output, and a digital compensation circuit helps reduce drift due to crystal deviation.

The RTC can also be automatically corrected with a 50/60Hz stable powerline.

The RTC calendar can be updated on the fly down to sub second precision, which enables network system synchronization.

A time stamp can record an external event occurrence, and generates an interrupt.

There are twenty 32-bit backup registers provided to store 80 bytes of user application data. They are cleared in case of tamper detection.

Three pins can be used to detect tamper events. A change on one of these pins can reset backup register and generate an interrupt. To prevent false tamper event, like ESD event, these three tamper inputs can be digitally filtered.

3.6 GPIOs (general-purpose inputs/outputs)

Each of the GPIO pins can be configured by software as output (push-pull or open-drain), as input (with or without pull-up or pull-down) or as peripheral alternate function. Most of the GPIO pins are shared with digital or analog alternate functions, and can be individually remapped using dedicated AFIO registers. All GPIOs are high current capable. The alternate function configuration of I/Os can be locked if needed following a specific sequence in order to avoid spurious writing to the I/O registers. The I/O controller is connected to the AHB with a toggling speed of up to 16 MHz.

External interrupt/event controller (EXTI)

The external interrupt/event controller consists of 24 edge detector lines used to generate interrupt/event requests. Each line can be individually configured to select the trigger event (rising edge, falling edge, both) and can be masked independently. A pending register maintains the status of the interrupt requests. The EXTI can detect an external line with a pulse width shorter than the Internal APB2 clock period. Up to 83 GPIOs can be connected to the 16 external interrupt lines. The 8 other lines are connected to RTC, PVD, USB, comparator events or capacitive sensing acquisition.

3.7 Memories

The STM32L100RC device has the following features:

- 16 Kbytes of embedded RAM accessed (read/write) at CPU clock speed with 0 wait states. With the enhanced bus matrix, operating the RAM does not lead to any performance penalty during accesses to the system bus (AHB and APB buses).
- The non-volatile memory is divided into three arrays:
 - 128 Kbytes of embedded Flash program memory
 - 4 Kbytes of data EEPROM
 - Options bytes

The options bytes are used to write-protect or read-out protect the memory (with 4 Kbytes granularity) and/or readout-protect the whole memory with the following options:

- Level 0: no readout protection
- Level 1: memory readout protection, the Flash memory cannot be read from or written to if either debug features are connected or boot in RAM is selected
- Level 2: chip readout protection, debug features (ARM Cortex-M3 JTAG and serial wire) and boot in RAM selection disabled (JTAG fuse)

The whole non-volatile memory embeds the error correction code (ECC) feature.

3.8 DMA (direct memory access)

The flexible 12-channel, general-purpose DMA is able to manage memory-to-memory, peripheral-to-memory and memory-to-peripheral transfers. The DMA controller supports circular buffer management, avoiding the generation of interrupts when the controller reaches the end of the buffer.

Each channel is connected to dedicated hardware DMA requests, with software trigger support for each channel. Configuration is done by software and transfer sizes between source and destination are independent.

The DMA can be used with the main peripherals: SPI, I²C, USART, general-purpose timers, DAC and ADC.

3.9 LCD (liquid crystal display)

The LCD drives up to 8 common terminals and 32 segment terminals to drive up to 320224 pixels.

- Internal step-up converter to guarantee functionality and contrast control irrespective of V_{DD} . This converter can be deactivated, in which case the V_{LCD} pin is used to provide the voltage to the LCD
- Supports static, 1/2, 1/3, 1/4 and 1/8 duty
- Supports static, 1/2, 1/3 and 1/4 bias
- Phase inversion to reduce power consumption and EMI
- Up to 8 pixels can be programmed to blink
- Unneeded segments and common pins can be used as general I/O pins
- LCD RAM can be updated at any time owing to a double-buffer
- The LCD controller can operate in Stop mode

3.10 ADC (analog-to-digital converter)

A 12-bit analog-to-digital converters is embedded into STM32L100RC device with up to 20 external channels, performing conversions in single-shot or scan mode. In scan mode, automatic conversion is performed on a selected group of analog inputs with up to 20 external channels in a group.

The ADC can be served by the DMA controller.

An analog watchdog feature allows very precise monitoring of the converted voltage of one, some or all scanned channels. An interrupt is generated when the converted voltage is outside the programmed thresholds.

The events generated by the general-purpose timers (TIMx) can be internally connected to the ADC start triggers, to allow the application to synchronize A/D conversions and timers. An injection mode allows high priority conversions to be done by interrupting a scan mode which runs in as a background task.

The ADC includes a specific low-power mode. The converter is able to operate at maximum speed even if the CPU is operating at a very low frequency and has an auto-shutdown function. The ADC's runtime and analog front-end current consumption are thus minimized whatever the MCU operating mode.

3.10.1 Internal voltage reference (V_{REFINT})

The internal voltage reference (V_{REFINT}) provides a stable (bandgap) voltage output for the ADC and Comparators. V_{REFINT} is internally connected to the ADC_IN17 input channel. It enables accurate monitoring of the V_{DD} value (when no external voltage, V_{REF+} , is available for ADC). The precise voltage of V_{REFINT} is individually measured for each part by ST during production test and stored in the system memory area. It is accessible in read-only mode. See [Table 14: Embedded internal reference voltage calibration values](#).

3.11 DAC (digital-to-analog converter)

The two 12-bit buffered DAC channels can be used to convert two digital signals into two analog voltage signal outputs. The chosen design structure is composed of integrated resistor strings and an amplifier in non-inverting configuration.

This dual digital Interface supports the following features:

- Two DAC converters: one for each output channel
- 8-bit or 12-bit monotonic output
- Left or right data alignment in 12-bit mode
- Synchronized update capability
- Noise-wave generation
- Triangular-wave generation
- Dual DAC channels, independent or simultaneous conversions
- DMA capability for each channel (including the underrun interrupt)
- External triggers for conversion
- Input reference voltage V_{REF+}

Eight DAC trigger inputs are used in the STM32L100RC device. The DAC channels are triggered through the timer update outputs that are also connected to different DMA channels.

3.12 Ultra-low-power comparators and reference voltage

The STM32L100RC device embeds two comparators sharing the same current bias and reference voltage. The reference voltage can be internal or external (coming from an I/O).

- One comparator with fixed threshold
- One comparator with rail-to-rail inputs, fast or slow mode. The threshold can be one of the following:
 - DAC output
 - External I/O
 - Internal reference voltage (V_{REFINT}) or a sub-multiple (1/4, 1/2, 3/4)

Both comparators can wake up from Stop mode, and be combined into a window comparator.

The internal reference voltage is available externally via a low-power / low-current output buffer (driving current capability of 1 μ A typical).

3.13 System configuration controller and routing interface

The system configuration controller provides the capability to remap some alternate functions on different I/O ports.

The highly flexible routing interface allows the application firmware to control the routing of different I/Os to the TIM2, TIM3 and TIM4 timer input captures. It also controls the routing of internal analog signals to ADC1, COMP1 and COMP2 and the internal reference voltage V_{REFINT} .

3.14 Timers and watchdogs

The ultra-low-power STM32L100RC device includes seven general-purpose timers, two basic timers, and two watchdog timers.

[Table 5](#) compares the features of the general-purpose and basic timers.

Table 5. Timer feature comparison

| Timer | Counter resolution | Counter type | Prescaler factor | DMA request generation | Capture/compare channels | Complementary outputs |
|------------------|--------------------|-------------------|---------------------------------|------------------------|--------------------------|-----------------------|
| TIM2, TIM3, TIM4 | 16-bit | Up, down, up/down | Any integer between 1 and 65536 | Yes | 4 | No |
| TIM9 | 16-bit | Up, down, up/down | Any integer between 1 and 65536 | No | 2 | No |
| TIM10, TIM11 | 16-bit | Up | Any integer between 1 and 65536 | No | 1 | No |
| TIM6, TIM7 | 16-bit | Up | Any integer between 1 and 65536 | Yes | 0 | No |

3.14.1 General-purpose timers (TIM2, TIM3, TIM4, TIM9, TIM10 and TIM11)

There are seven synchronizable general-purpose timers embedded in the STM32L100RC device (see [Table 5](#) for differences).

TIM2, TIM3, TIM4

TIM2, TIM3, TIM4 are based on 16-bit auto-reload up/down counter. They include a 16-bit prescaler. They feature four independent channels each for input capture/output compare, PWM or one-pulse mode output. This gives up to 16 input captures/output compares/PWMs on the largest packages.

TIM2, TIM3, TIM4 general-purpose timers can work together or with the TIM10, TIM11 and TIM9 general-purpose timers via the Timer Link feature for synchronization or event chaining. Their counter can be frozen in debug mode. Any of the general-purpose timers can be used to generate PWM outputs.

TIM2, TIM3, TIM4 all have independent DMA request generation.

These timers are capable of handling quadrature (incremental) encoder signals and the digital outputs from 1 to 3 hall-effect sensors.

TIM10, TIM11 and TIM9

TIM10 and TIM11 are based on a 16-bit auto-reload upcounter. TIM9 is based on a 16-bit auto-reload up/down counter. They include a 16-bit prescaler. TIM10 and TIM11 feature one independent channel, whereas TIM9 has two independent channels for input capture/output compare, PWM or one-pulse mode output. They can be synchronized with the TIM2, TIM3, TIM4 full-featured general-purpose timers.

They can also be used as simple time bases and be clocked by the LSE clock source (32.768 kHz) to provide time bases independent from the main CPU clock.

3.14.2 Basic timers (TIM6 and TIM7)

These timers are mainly used for DAC trigger generation. They can also be used as generic 16-bit time bases.

3.14.3 SysTick timer

This timer is dedicated to the OS, but could also be used as a standard downcounter. It is based on a 24-bit downcounter with autoreload capability and a programmable clock source. It features a maskable system interrupt generation when the counter reaches 0.

3.14.4 Independent watchdog (IWDG)

The independent watchdog is based on a 12-bit downcounter and 8-bit prescaler. It is clocked from an independent 37 kHz internal RC and, as it operates independently of the main clock, it can operate in Stop and Standby modes. It can be used either as a watchdog to reset the device when a problem occurs, or as a free-running timer for application timeout management. It is hardware- or software-configurable through the option bytes. The counter can be frozen in debug mode.

3.14.5 Window watchdog (WWDG)

The window watchdog is based on a 7-bit downcounter that can be set as free-running. It can be used as a watchdog to reset the device when a problem occurs. It is clocked from the main clock. It has an early warning interrupt capability and the counter can be frozen in debug mode.

3.15 Communication interfaces

3.15.1 I²C bus

Up to two I²C bus interfaces can operate in multimaster and slave modes. They can support standard and fast modes.

They support dual slave addressing (7-bit only) and both 7- and 10-bit addressing in master mode. A hardware CRC generation/verification is embedded.

They can be served by DMA and they support SM Bus 2.0/PM Bus.

3.15.2 Universal synchronous/asynchronous receiver transmitter (USART)

The three USART interfaces are able to communicate at speeds of up to 4 Mbit/s. They support IrDA SIR ENDEC and have LIN Master/Slave capability. The three USARTs provide hardware management of the CTS and RTS signals and are ISO 7816 compliant.

All USART interfaces can be served by the DMA controller.

3.15.3 Serial peripheral interface (SPI)

Up to three SPIs are able to communicate at up to 16 Mbits/s in slave and master modes in full-duplex and half-duplex communication modes. The 3-bit prescaler gives 8 master mode frequencies and the frame is configurable to 8 bits or 16 bits. The hardware CRC generation/verification supports basic SD Card/MMC modes.

The SPIs can be served by the DMA controller.

3.15.4 Universal serial bus (USB)

The STM32L100RC device embeds a USB device peripheral compatible with the USB full-speed 12 Mbit/s. The USB interface implements a full-speed (12 Mbit/s) function interface. It has software-configurable endpoint setting and supports suspend/resume. The dedicated 48 MHz clock is generated from the internal main PLL (the clock source must use a HSE crystal oscillator).

3.16 CRC (cyclic redundancy check) calculation unit

The CRC (cyclic redundancy check) calculation unit is used to get a CRC code from a 32-bit data word and a fixed generator polynomial.

Among other applications, CRC-based techniques are used to verify data transmission or storage integrity. In the scope of the EN/IEC 60335-1 standard, they offer a means of verifying the Flash memory integrity. The CRC calculation unit helps compute a signature of the software during runtime, to be compared with a reference signature generated at link-time and stored at a given memory location.

3.17 Development support

3.17.1 Serial wire JTAG debug port (SWJ-DP)

The ARM SWJ-DP interface is embedded, and is a combined JTAG and serial wire debug port that enables either a serial wire debug or a JTAG probe to be connected to the target. The JTAG JTMS and JTCK pins are shared with SWDAT and SWCLK, respectively, and a specific sequence on the JTMS pin is used to switch between JTAG-DP and SW-DP.

The JTAG port can be permanently disabled with a JTAG fuse.

3.17.2 Embedded Trace Macrocell™

The ARM® Embedded Trace Macrocell provides a greater visibility of the instruction and data flow inside the CPU core by streaming compressed data at a very high rate from the STM32L100RC devices through a small number of ETM pins to an external hardware trace port analyzer (TPA) device. The TPA is connected to a host computer using USB, Ethernet, or any other high-speed channel. Real-time instruction and data flow activity can be recorded and then formatted for display on the host computer running debugger software. TPA hardware is commercially available from common development tool vendors. It operates with third party debugger software tools.

4 Pin descriptions

Figure 3. STM32L100RC LQFP64 pinout

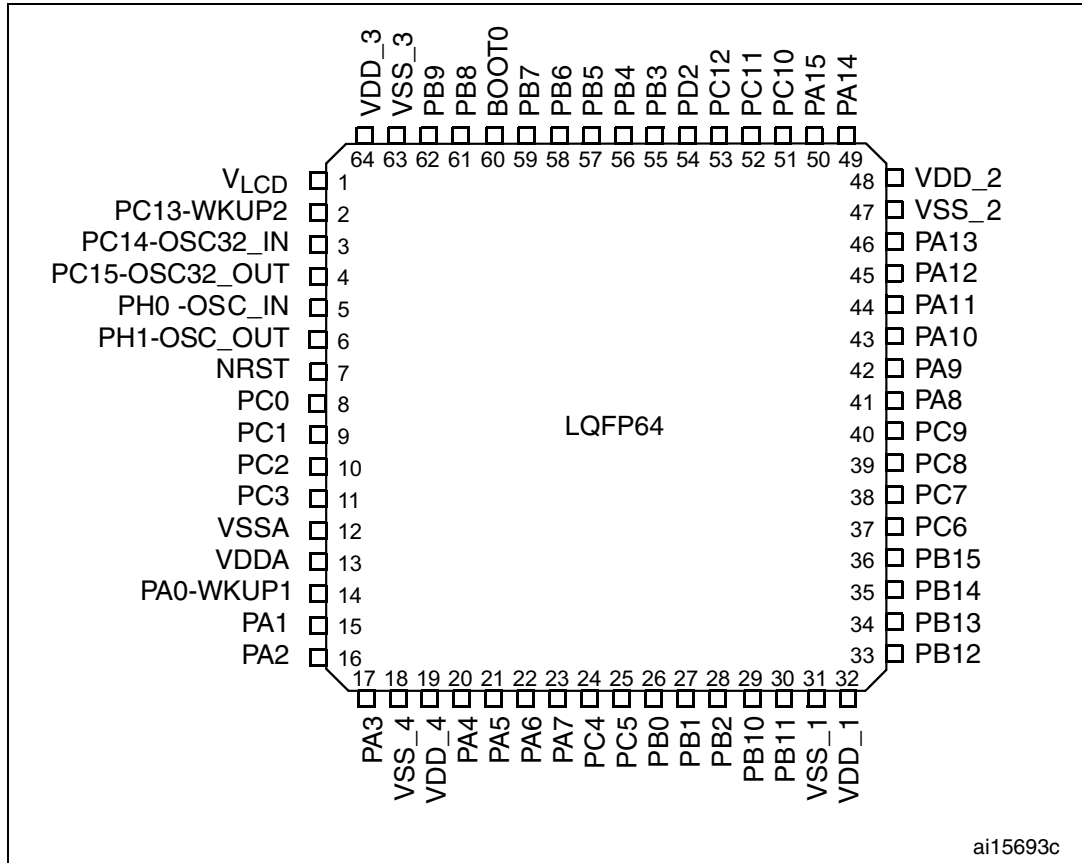

1. This figure shows the package top view.

Table 6. Legend/abbreviations used in the pinout table

| Name | | Abbreviation | Definition |
|---------------|----------------------|---|---|
| Pin name | | Unless otherwise specified in brackets below the pin name, the pin function during and after reset is the same as the actual pin name | |
| Pin type | | S | Supply pin |
| | | I | Input only pin |
| | | I/O | Input / output pin |
| I/O structure | | FT | 5 V tolerant I/O |
| | | TC | Standard 3.3 V I/O |
| | | B | Dedicated BOOT0 pin |
| | | RST | Bidirectional reset pin with embedded weak pull-up resistor |
| Notes | | Unless otherwise specified by a note, all I/Os are set as floating inputs during and after reset | |
| Pin functions | Alternate functions | Functions selected through GPIOx_AFR registers | |
| | Additional functions | Functions directly selected/enabled through peripheral registers | |

Table 7. STM32L100RC pin definitions

| Pins | Pin name | Type ⁽¹⁾ | I / O Level ⁽²⁾ | Main function (after reset) | Pin functions | |
|------|-----------------------------------|---------------------|----------------------------|-----------------------------|---------------------|------------------------------------|
| | | | | | Alternate functions | Additional functions |
| 1 | V _{LCD} | S | - | V _{LCD} | - | - |
| 2 | PC13-WKUP2 | I/O | FT | PC13 | - | WKUP2/RTC_TAMP1/ RTC_TS/RTC_OUT |
| 3 | PC14- OSC32_IN ⁽³⁾ | I/O | - | PC14 | - | OSC32_IN |
| 4 | PC15- OSC32_OUT ⁽³⁾ | I/O | - | PC15 | - | OSC32_OUT |
| 5 | PH0-OSC_IN ⁽⁴⁾ | I | - | PH0 | - | OSC_IN |
| 6 | PH1- OSC_OUT ⁽⁴⁾ | O | - | PH1 | - | OSC_OUT |
| 7 | NRST | I/O | | NRST | - | - |
| 8 | PC0 | I/O | FT | PC0 | LCD_SEG18 | ADC_IN10/COMP1_INP |
| 9 | PC1 | I/O | FT | PC1 | LCD_SEG19 | ADC_IN11/COMP1_INP |



Table 7. STM32L100RC pin definitions (continued)

| Pins | Pin name | Type ⁽¹⁾ | I / O Level ⁽²⁾ | Main function (after reset) | Pin functions | |
|------|-------------------|---------------------|----------------------------|-----------------------------|---|--|
| | | | | | Alternate functions | Additional functions |
| 10 | PC2 | I/O | FT | PC2 | LCD_SEG20 | ADC_IN12/COMP1_INP |
| 11 | PC3 | I/O | - | PC3 | LCD_SEG21 | ADC_IN13/COMP1_INP |
| 12 | V _{SSA} | S | - | V _{SSA} | - | - |
| 13 | V _{DDA} | S | - | V _{DDA} | - | - |
| 14 | PA0-WKUP1 | I/O | FT | PA0 | TIM2_CH1_ETR/ USART2_CTS | WKUP1/RTC_TAMP2/ ADC_IN0/COMP1_INP |
| 15 | PA1 | I/O | FT | PA1 | TIM2_CH2/USART2_RTS/ LCD_SEG0 | ADC_IN1/COMP1_INP/ OPAMP1_VINP |
| 16 | PA2 | I/O | FT | PA2 | TIM2_CH3/TIM9_CH1/ USART2_TX/LCD_SEG1 | ADC_IN2/ COMP1_INP/ OPAMP1_VINM |
| 17 | PA3 | I/O | - | PA3 | TIM2_CH4/TIM9_CH2 /USART2_RX/LCD_SEG2 | ADC_IN3/ COMP1_INP/OPAMP1_VOUT |
| 18 | V _{SS_4} | S | - | V _{SS_4} | - | - |
| 19 | V _{DD_4} | S | - | V _{DD_4} | - | - |
| 20 | PA4 | I/O | - | PA4 | SPI1_NSS/SPI3_NSS/ I2S3_WS/USART2_CK | ADC_IN4/DAC_OUT1/ COMP1_INP |
| 21 | PA5 | I/O | - | PA5 | TIM2_CH1_ETR/SPI1_SCK | ADC_IN5/ DAC_OUT2/COMP1_INP |
| 22 | PA6 | I/O | FT | PA6 | TIM3_CH1/TIM10_CH1/ SPI1_MISO/LCD_SEG3 | ADC_IN6/COMP1_INP/ OPAMP2_VINP |
| 23 | PA7 | I/O | FT | PA7 | TIM3_CH2/TIM11_CH1/ SPI1_MOSI/LCD_SEG4 | ADC_IN7/COMP1_INP /OPAMP2_VINM |
| 24 | PC4 | I/O | FT | PC4 | LCD_SEG22 | ADC_IN14/COMP1_INP |
| 25 | PC5 | I/O | FT | PC5 | LCD_SEG23 | ADC_IN15/COMP1_INP |
| 26 | PB0 | I/O | - | PB0 | TIM3_CH3/LCD_SEG5 | ADC_IN8/COMP1_INP/ OPAMP2_VOUT/VREF_OUT |
| 27 | PB1 | I/O | FT | PB1 | TIM3_CH4/LCD_SEG6 | ADC_IN9/ COMP1_INP/VREF_OUT |
| 28 | PB2 | I/O | FT | PB2/BOOT1 | BOOT1 | COMP1_INP |
| 29 | PB10 | I/O | FT | PB10 | TIM2_CH3/I2C2_SCL/ USART3_TX/LCD_SEG10 | - |
| 30 | PB11 | I/O | FT | PB11 | TIM2_CH4/I2C2_SDA/ USART3_RX/LCD_SEG11 | - |

Table 7. STM32L100RC pin definitions (continued)

| Pins | Pin name | Type ⁽¹⁾ | I / O Level ⁽²⁾ | Main function (after reset) | Pin functions | |
|------|-------------------|---------------------|----------------------------|-----------------------------|--|----------------------------------|
| | | | | | Alternate functions | Additional functions |
| 31 | V _{SS_1} | S | - | V _{SS_1} | - | - |
| 32 | V _{DD_1} | S | - | V _{DD_1} | - | - |
| 33 | PB12 | I/O | FT | PB12 | TIM10_CH1/I2C2_SMBA/ SPI2_NSS/I2S2_WS/ USART3_CK/LCD_SEG12 | ADC_IN18/COMP1_INP |
| 34 | PB13 | I/O | FT | PB13 | TIM9_CH1/SPI2_SCK/ I2S2_CK/ USART3_CTS/ LCD_SEG13 | ADC_IN19/COMP1_INP |
| 35 | PB14 | I/O | FT | PB14 | TIM9_CH2/SPI2_MISO/ USART3_RTS/LCD_SEG14 | ADC_IN20/COMP1_INP |
| 36 | PB15 | I/O | FT | PB15 | TIM11_CH1/SPI2_MOSI/ I2S2_SD/LCD_SEG15 | ADC_IN21/COMP1_INP/ RTC_REFIN |
| 37 | PC6 | I/O | FT | PC6 | TIM3_CH1/I2S2_MCK/ LCD_SEG24 | - |
| 38 | PC7 | I/O | FT | PC7 | TIM3_CH2/I2S3_MCK/ LCD_SEG25 | - |
| 39 | PC8 | I/O | FT | PC8 | TIM3_CH3/LCD_SEG26 | - |
| 40 | PC9 | I/O | FT | PC9 | TIM3_CH4/LCD_SEG27 | - |
| 41 | PA8 | I/O | FT | PA8 | USART1_CK/MCO/ LCD_COM0 | - |
| 42 | PA9 | I/O | FT | PA9 | USART1_TX/LCD_COM1 | - |
| 43 | PA10 | I/O | FT | PA10 | USART1_RX/LCD_COM2 | - |
| 44 | PA11 | I/O | FT | PA11 | USART1_CTS/SPI1_MISO | USB_DM |
| 45 | PA12 | I/O | FT | PA12 | USART1_RTS/SPI1_MOSI | USB_DP |
| 46 | PA13 | I/O | FT | JTMS-SWDIO | JTMS-SWDIO | - |
| 47 | V _{SS_2} | S | | V _{SS_2} | - | - |
| 48 | V _{DD_2} | S | | V _{DD_2} | - | - |
| 49 | PA14 | I/O | FT | JTCK-SWCLK | JTCK-SWCLK | - |
| 50 | PA15 | I/O | FT | JTDI | TIM2_CH1_ETR/SPI1_NSS/ SPI3_NSS/ I2S3_WS/LCD_SEG17/JTDI | - |

Table 7. STM32L100RC pin definitions (continued)

| Pins | Pin name | Type ⁽¹⁾ | I / O Level ⁽²⁾ | Main function (after reset) | Pin functions | |
|------|-------------------|---------------------|----------------------------|-----------------------------|--|----------------------|
| | | | | | Alternate functions | Additional functions |
| 51 | PC10 | I/O | FT | PC10 | SPI3_SCK/I2S3_CK/ USART3_TX/LCD_SEG28/ LCD_SEG40/LCD_COM4 | - |
| 52 | PC11 | I/O | FT | PC11 | SPI3_MISO/USART3_RX/ LCD_SEG29 /LCD_SEG41/LCD_COM5 | - |
| 53 | PC12 | I/O | FT | PC12 | SPI3_MOSI/I2S3_SD/ USART3_CK/LCD_SEG30/ LCD_SEG42/LCD_COM6 | - |
| 54 | PD2 | I/O | FT | PD2 | TIM3_ETR/LCD_SEG31/ LCD_SEG43/LCD_COM7 | - |
| 55 | PB3 | I/O | FT | JTDO | TIM2_CH2/SPI1_SCK/ SPI3_SCK/I2S3_CK/ LCD_SEG7/JTDO | COMP2_INM |
| 56 | PB4 | I/O | FT | NJTRST | TIM3_CH1/SPI1_MISO/ SPI3_MISO/LCD_SEG8/ NJTRST | COMP2_INP |
| 57 | PB5 | I/O | FT | PB5 | TIM3_CH2/I2C1_SMBA/ SPI1_MOSI/SPI3_MOSI/ I2S3_SD/LCD_SEG9 | COMP2_INP |
| 58 | PB6 | I/O | FT | PB6 | TIM4_CH1/I2C1_SCL/ USART1_TX | COMP2_INP |
| 59 | PB7 | I/O | FT | PB7 | TIM4_CH2/I2C1_SDA/ USART1_RX | COMP2_INP/PVD_IN |
| 60 | BOOT0 | I | - | BOOT0 | - | - |
| 61 | PB8 | I/O | FT | PB8 | TIM4_CH3/TIM10_CH1/ I2C1_SCL/LCD_SEG16 | - |
| 62 | PB9 | I/O | FT | PB9 | TIM4_CH4/TIM11_CH1/ I2C1_SDA/LCD_COM3 | - |
| 63 | V _{SS_3} | S | - | V _{SS_3} | - | - |
| 64 | V _{DD_3} | S | - | V _{DD_3} | - | - |

1. I = input, O = output, S = supply.

2. FT = 5 V tolerant.

3. The PC14 and PC15 I/Os are only configured as OSC32_IN/OSC32_OUT when the LSE oscillator is ON (by setting the LSEON bit in the RCC_CSR register). The LSE oscillator pins OSC32_IN/OSC32_OUT can be used as general-purpose PH0/PH1 I/Os, respectively, when the LSE oscillator is off (after reset, the LSE oscillator is off). The LSE has priority over the GPIO function. For more details, refer to Using the OSC32_IN/OSC32_OUT pins as GPIO PC14/PC15 port pins section in the STM32L100xx, STM32L151xx, STM32L152xx and STM32L162xx reference manual (RM0038).

4. The PH0 and PH1 I/Os are only configured as OSC_IN/OSC_OUT when the HSE oscillator is ON (by setting the HSEON bit in the RCC_CR register). The HSE oscillator pins OSC_IN/OSC_OUT can be used as general-purpose PH0/PH1 I/Os, respectively, when the HSE oscillator is off (after reset, the HSE oscillator is off). The HSE has priority over the GPIO function.

Alternate functions



Table 8. Alternate function input/output

| Port name | Digital alternate function number | | | | | | | | | | | | |
|-----------|-----------------------------------|--------------|----------|----------------|--------|-----------|---------------------|------------|------|--------|----------|--------|--------------|
| | AFIO0 | AFIO1 | AFIO2 | AFIO3 | AFIO4 | AFIO5 | AFIO6 | AFIO7 | : | AFIO11 | : | AFIO14 | AFIO15 |
| | Alternate function | | | | | | | | | | | | |
| | SYSTEM | TIM2 | TIM3/4 | TIM9/ 10/11 | I2C1/2 | SPI1/2 | SPI3 | USART1/2/3 | | LCD | | CPRI | SYSTEM |
| BOOT0 | BOOT0 | - | - | - | - | - | - | - | - | - | - | - | EVENT OUT |
| NRST | NRST | - | - | - | - | - | - | - | - | - | - | - | - |
| PA0-WKUP1 | - | TIM2_CH1_ETR | - | - | - | - | - | USART2_CTS | - | - | TIMx_IC1 | - | EVENT OUT |
| PA1 | - | TIM2_CH2 | - | - | - | - | - | USART2_RTS | SEG0 | - | TIMx_IC2 | - | EVENT OUT |
| PA2 | - | TIM2_CH3 | - | TIM9_CH1 | - | - | - | USART2_TX | SEG1 | - | TIMx_IC3 | - | EVENT OUT |
| PA3 | - | TIM2_CH4 | - | TIM9_CH2 | - | - | - | USART2_RX | SEG2 | - | TIMx_IC4 | - | EVENT OUT |
| PA4 | - | - | - | - | - | SPI1_NSS | SPI3_NSS I2S3_WS | USART2_CK | - | - | TIMx_IC1 | - | EVENT OUT |
| PA5 | - | TIM2_CH1_ETR | - | - | - | SPI1_SCK | - | - | - | - | TIMx_IC2 | - | EVENT OUT |
| PA6 | - | - | TIM3_CH1 | TIM10_CH1 | - | SPI1_MISO | - | - | SEG3 | - | TIMx_IC3 | - | EVENT OUT |
| PA7 | - | - | TIM3_CH2 | TIM11_CH1 | - | SPI1_MOSI | - | - | SEG4 | - | TIMx_IC4 | - | EVENT OUT |
| PA8 | MCO | - | - | - | - | - | - | USART1_CK | COM0 | - | TIMx_IC1 | - | EVENT OUT |
| PA9 | - | - | - | - | - | - | - | USART1_TX | COM1 | - | TIMx_IC2 | - | EVENT OUT |
| PA10 | - | - | - | - | - | - | - | USART1_RX | COM2 | - | TIMx_IC3 | - | EVENT OUT |
| PA11 | - | - | - | - | - | SPI1_MISO | - | USART1_CTS | - | - | TIMx_IC4 | - | EVENT OUT |

Table 8. Alternate function input/output (continued)

| Port name | Digital alternate function number | | | | | | | | | | |
|-----------|-----------------------------------|--------------|----------|----------------|---------------|-----------|----------------------|------------|--------|----------|--------------|
| | AFIO0 | AFIO1 | AFIO2 | AFIO3 | AFIO4 | AFIO5 | AFIO6 | AFIO7 | AFIO11 | AFIO14 | AFIO15 |
| | Alternate function | | | | | | | | | | |
| | SYSTEM | TIM2 | TIM3/4 | TIM9/ 10/11 | I2C1/2 | SPI1/2 | SPI3 | USART1/2/3 | LCD | CPRI | SYSTEM |
| PA12 | - | - | - | - | - | SPI1_MOSI | - | USART1_RTS | - | TIMx_IC1 | EVENT OUT |
| PA13 | JTMS-SWDIO | - | - | - | - | - | - | - | - | TIMx_IC2 | EVENT OUT |
| PA14 | JTCK-SWCLK | - | - | - | - | - | - | - | - | TIMx_IC3 | EVENT OUT |
| PA15 | JTDI | TIM2_CH1_ETR | - | - | - | SPI1_NSS | SPI3_NSS I2S3_WS | - | SEG17 | TIMx_IC4 | EVENT OUT |
| PB0 | - | - | TIM3_CH3 | - | - | - | - | - | SEG5 | - | EVENT OUT |
| PB1 | - | - | TIM3_CH4 | - | - | - | - | - | SEG6 | - | EVENT OUT |
| PB2 | BOOT1 | - | - | - | - | - | - | - | - | - | EVENT OUT |
| PB3 | JTDO | TIM2_CH2 | - | - | - | SPI1_SCK | SPI3_SCK I2S3_CK | - | SEG7 | - | EVENT OUT |
| PB4 | NJTRST | - | TIM3_CH1 | - | - | SPI1_MISO | SPI3_MISO | - | SEG8 | - | EVENT OUT |
| PB5 | - | - | TIM3_CH2 | - | I2C1_ SMBA | SPI1_MOSI | SPI3_MOSI I2S3_SD | - | SEG9 | - | EVENT OUT |
| PB6 | - | - | TIM4_CH1 | - | I2C1_SCL | - | - | USART1_TX | - | - | EVENT OUT |
| PB7 | - | - | TIM4_CH2 | - | I2C1_SDA | - | - | USART1_RX | - | - | EVENT OUT |
| PB8 | - | - | TIM4_CH3 | TIM10_CH1 | I2C1_SCL | - | - | - | SEG16 | - | EVENT OUT |
| PB9 | - | - | TIM4_CH4 | TIM11_CH1 | I2C1_SDA | - | - | - | COM3 | - | EVENT OUT |
| PB10 | - | TIM2_CH3 | - | - | I2C2_SCL | - | - | USART3_TX | SEG10 | - | EVENT OUT |



Table 8. Alternate function input/output (continued)

| Port name | Digital alternate function number | | | | | | | | | | |
|-----------|-----------------------------------|----------|----------|----------------|-----------|----------------------|----------|------------|--------|----------|--------------|
| | AFIO0 | AFIO1 | AFIO2 | AFIO3 | AFIO4 | AFIO5 | AFIO6 | AFIO7 | AFIO11 | AFIO14 | AFIO15 |
| | Alternate function | | | | | | | | | | |
| | SYSTEM | TIM2 | TIM3/4 | TIM9/ 10/11 | I2C1/2 | SPI1/2 | SPI3 | USART1/2/3 | LCD | CPRI | SYSTEM |
| PB11 | - | TIM2_CH4 | - | - | I2C2_SDA | - | - | USART3_RX | SEG11 | - | EVENT OUT |
| PB12 | - | - | - | TIM10_CH1 | I2C2_SMBA | SPI2_NSS I2S2_WS | - | USART3_CK | SEG12 | - | EVENT OUT |
| PB13 | - | - | - | TIM9_CH1 | - | SPI2_SCK I2S2_CK | - | USART3_CTS | SEG13 | - | EVENT OUT |
| PB14 | - | - | - | TIM9_CH2 | - | SPI2_MISO | - | USART3_RTS | SEG14 | - | EVENT OUT |
| PB15 | - | - | - | TIM11_CH1 | - | SPI2_MOSI I2S2_SD | - | - | SEG15 | - | EVENT OUT |
| PC0 | - | - | - | - | - | - | - | - | SEG18 | TIMx_IC1 | EVENT OUT |
| PC1 | - | - | - | - | - | - | - | - | SEG19 | TIMx_IC2 | EVENT OUT |
| PC2 | - | - | - | - | - | - | - | - | SEG20 | TIMx_IC3 | EVENT OUT |
| PC3 | - | - | - | - | - | - | - | - | SEG21 | TIMx_IC4 | EVENT OUT |
| PC4 | - | - | - | - | - | - | - | - | SEG22 | TIMx_IC1 | EVENT OUT |
| PC5 | - | - | - | - | - | - | - | - | SEG23 | TIMx_IC2 | EVENT OUT |
| PC6 | - | - | TIM3_CH1 | - | - | I2S2_MCK | - | - | SEG24 | TIMx_IC3 | EVENT OUT |
| PC7 | - | - | TIM3_CH2 | - | - | - | I2S3_MCK | - | SEG25 | TIMx_IC4 | EVENT OUT |
| PC8 | - | - | TIM3_CH3 | - | - | - | - | - | SEG26 | TIMx_IC1 | EVENT OUT |
| PC9 | - | - | TIM3_CH4 | - | - | - | - | - | SEG27 | TIMx_IC2 | EVENT OUT |

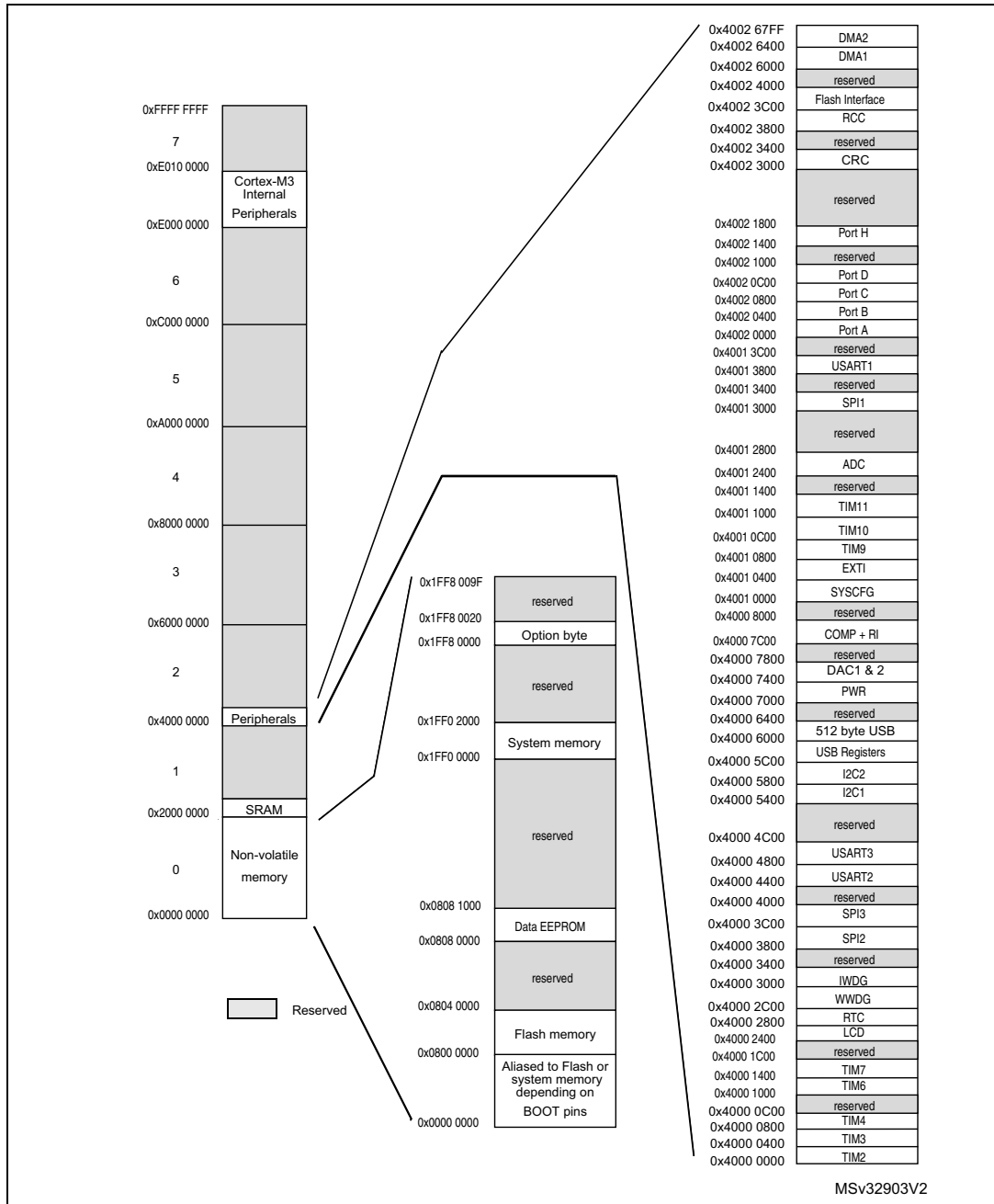

Table 8. Alternate function input/output (continued)

| Port name | Digital alternate function number | | | | | | | | | | |
|-------------------|-----------------------------------|-------|----------|----------------|--------|--------|----------------------|------------|--------------------------|----------|--------------|
| | AFIO0 | AFIO1 | AFIO2 | AFIO3 | AFIO4 | AFIO5 | AFIO6 | AFIO7 | AFIO11 | AFIO14 | AFIO15 |
| | Alternate function | | | | | | | | | | |
| | SYSTEM | TIM2 | TIM3/4 | TIM9/ 10/11 | I2C1/2 | SPI1/2 | SPI3 | USART1/2/3 | LCD | CPRI | SYSTEM |
| PC10 | - | - | - | - | - | - | SPI3_SCK I2S3_CK | USART3_TX | COM4/ SEG28/ SEG40 | TIMx_IC3 | EVENT OUT |
| PC11 | - | - | - | - | - | - | SPI3_MISO | USART3_RX | COM5/ SEG29 /SEG41 | TIMx_IC4 | EVENT OUT |
| PC12 | - | - | - | - | - | - | SPI3_MOSI I2S3_SD | USART3_CK | COM6/ SEG30/ SEG42 | TIMx_IC1 | EVENT OUT |
| PC13-WKUP2 | - | - | - | - | - | - | - | - | - | TIMx_IC2 | EVENT OUT |
| PC14 OSC32_IN | - | - | - | - | - | - | - | - | - | TIMx_IC3 | EVENT OUT |
| PC15 OSC32_OUT | - | - | - | - | - | - | - | - | - | TIMx_IC4 | EVENT OUT |
| PD2 | - | - | TIM3_ETR | - | - | - | - | - | COM7/ SEG31/ SEG43 | TIMx_IC3 | EVENT OUT |
| PH0OSC_IN | - | - | - | - | - | - | - | - | - | - | - |
| PH1OSC_OUT | - | - | - | - | - | - | - | - | - | - | - |

5 Memory mapping

Figure 4. Memory map



6 Electrical characteristics

6.1 Parameter conditions

Unless otherwise specified, all voltages are referenced to V_{SS} .

6.1.1 Minimum and maximum values

Unless otherwise specified the minimum and maximum values are guaranteed in the worst conditions of ambient temperature, supply voltage and frequencies by tests in production on 100% of the device with an ambient temperature at $T_A = 25\text{ }^\circ\text{C}$ and $T_A = T_{Amax}$ (given by the selected temperature range).

Data based on characterization results, design simulation and/or technology characteristics are indicated in the table footnotes. Based on characterization, the minimum and maximum values refer to sample tests and represent the mean value plus or minus three times the standard deviation (mean $\pm 3\sigma$).

6.1.2 Typical values

Unless otherwise specified, typical data are based on $T_A = 25\text{ }^\circ\text{C}$, $V_{DD} = 3.6\text{ V}$ (for the $1.65\text{ V} \leq V_{DD} \leq 3.6\text{ V}$ voltage range). They are given only as design guidelines and are not tested.

Typical ADC accuracy values are determined by characterization of a batch of samples from a standard diffusion lot over the full temperature range, where 95% of the device have an error less than or equal to the value indicated (mean $\pm 2\sigma$).

6.1.3 Typical curves

Unless otherwise specified, all typical curves are given only as design guidelines and are not tested.

6.1.4 Loading capacitor

The loading conditions used for pin parameter measurement are shown in [Figure 5](#).

6.1.5 Pin input voltage

The input voltage measurement on a pin of the device is described in [Figure 6](#).

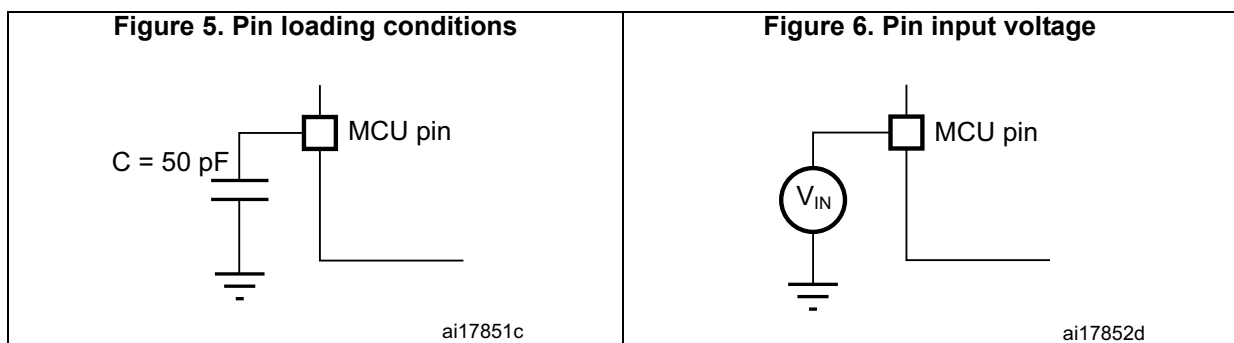

6.1.6 Power supply scheme

Figure 7. Power supply scheme

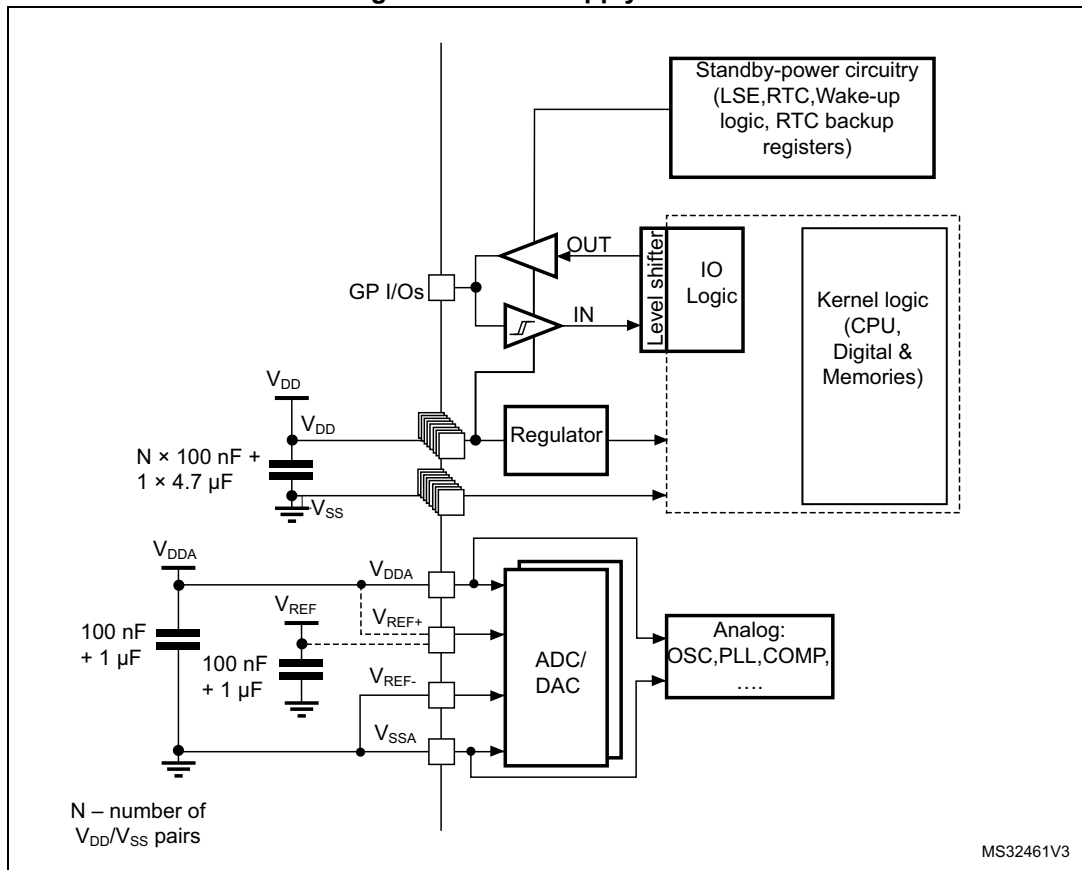

6.1.7 Optional LCD power supply scheme

Figure 8. Optional LCD power supply scheme

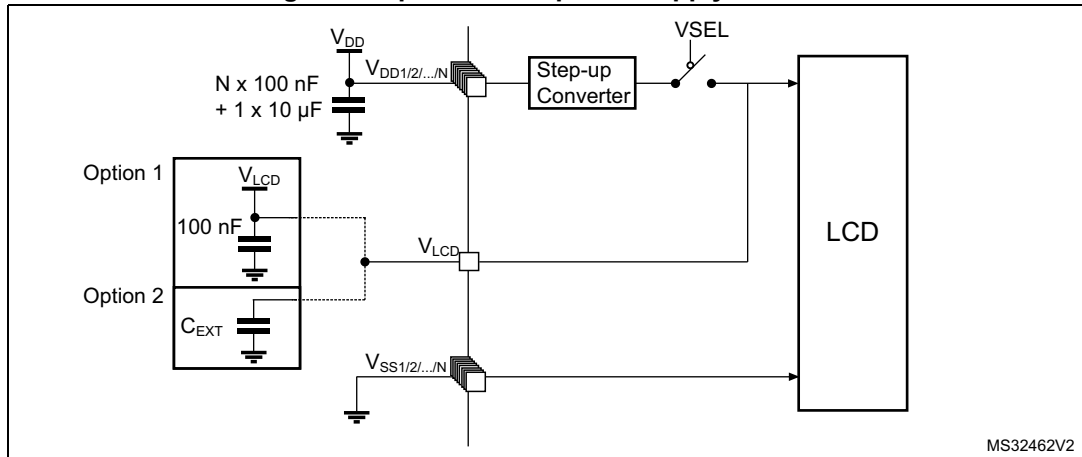

1. Option 1: LCD power supply is provided by a dedicated VLCD supply source, VSEL switch is open.
2. Option 2: LCD power supply is provided by the internal step-up converter, VSEL switch is closed, an external capacitance is needed for correct behavior of this converter.

6.1.8 Current consumption measurement

Figure 9. Current consumption measurement scheme

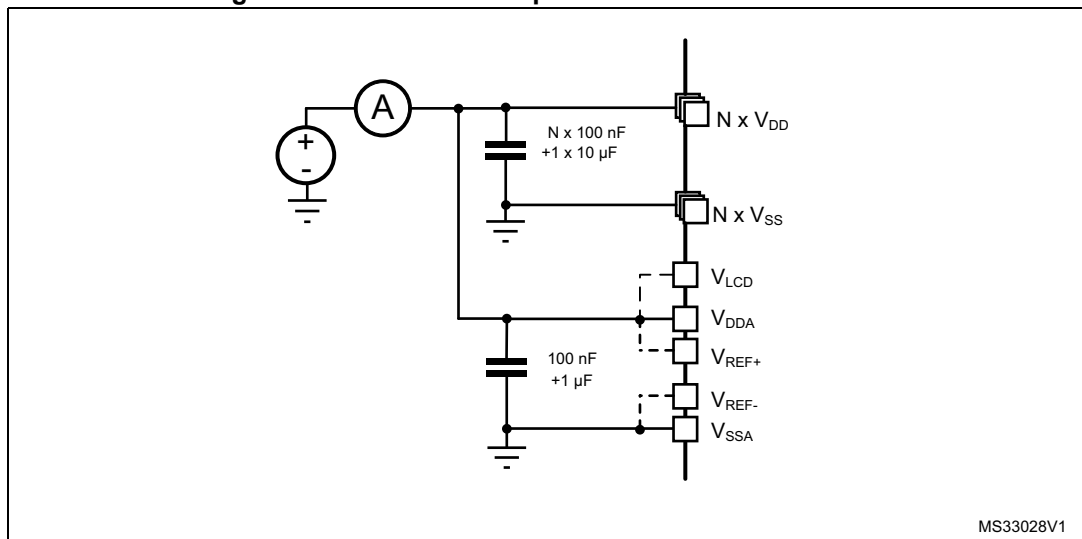

6.2 Absolute maximum ratings

Stresses above the absolute maximum ratings listed in [Table 9: Voltage characteristics](#), [Table 10: Current characteristics](#), and [Table 11: Thermal characteristics](#) may cause permanent damage to the device. These are stress ratings only and functional operation of the device at these conditions is not implied. Exposure to maximum rating conditions for extended periods may affect device reliability.

Table 9. Voltage characteristics

| Symbol | Ratings | Min | Max | Unit |
|--------------------|---|------------------------------------|--------------|------|
| $V_{DD}-V_{SS}$ | External main supply voltage (including V_{DDA} and V_{DD}) ⁽¹⁾ | -0.3 | 4.0 | V |
| $V_{IN}^{(2)}$ | Input voltage on five-volt tolerant pin | $V_{SS}-0.3$ | $V_{DD}+4.0$ | |
| | Input voltage on any other pin | $V_{SS}-0.3$ | 4.0 | |
| $ \Delta V_{DDx} $ | Variations between different V_{DD} power pins | - | 50 | mV |
| $ V_{SSx}-V_{SS} $ | Variations between all different ground pins ⁽³⁾ | - | 50 | |
| $V_{REF+}-V_{DDA}$ | Allowed voltage difference for $V_{REF+} > V_{DDA}$ | - | 0.4 | V |
| $V_{ESD(HBM)}$ | Electrostatic discharge voltage (human body model) | see Section 6.3.11 | | |

1. All main power (V_{DD} , V_{DDA}) and ground (V_{SS} , V_{SSA}) pins must always be connected to the external power supply, in the permitted range.
2. V_{IN} maximum must always be respected. Refer to [Table 10](#) for maximum allowed injected current values.
3. Include V_{REF-} pin.

Table 10. Current characteristics

| Symbol | Ratings | Max. | Unit |
|-------------------------|--|-------|------|
| $I_{VDD(\Sigma)}$ | Total current into sum of all V_{DD_x} power lines (source) ⁽¹⁾ | 100 | mA |
| $I_{VSS(\Sigma)}^{(2)}$ | Total current out of sum of all V_{SS_x} ground lines (sink) ⁽¹⁾ | 100 | |
| $I_{VDD(PIN)}$ | Maximum current into each V_{DD_x} power pin (source) ⁽¹⁾ | 70 | |
| $I_{VSS(PIN)}$ | Maximum current out of each V_{SS_x} ground pin (sink) ⁽¹⁾ | -70 | |
| I_{IO} | Output current sunk by any I/O and control pin | 25 | |
| | Output current sourced by any I/O and control pin | - 25 | |
| $\Sigma I_{IO(PIN)}$ | Total output current sunk by sum of all IOs and control pins ⁽²⁾ | 60 | |
| | Total output current sourced by sum of all IOs and control pins ⁽²⁾ | -60 | |
| $I_{INJ(PIN)}^{(3)}$ | Injected current on five-volt tolerant I/O ⁽⁴⁾ , RST and B pins | -5/+0 | |
| | Injected current on any other pin ⁽⁵⁾ | ± 5 | |
| $\Sigma I_{INJ(PIN)}$ | Total injected current (sum of all I/O and control pins) ⁽⁶⁾ | ± 25 | |

1. All main power (V_{DD} , V_{DDA}) and ground (V_{SS} , V_{SSA}) pins must always be connected to the external power supply, in the permitted range.
2. This current consumption must be correctly distributed over all I/Os and control pins. The total output current must not be sunk/sourced between two consecutive power supply pins referring to high pin count LQFP packages.
3. Negative injection disturbs the analog performance of the device. See note in [Section 6.3.17](#).

4. Positive current injection is not possible on these I/Os. A negative injection is induced by $V_{IN} < V_{SS}$. $I_{INJ(PIN)}$ must never be exceeded. Refer to [Table 9](#) for maximum allowed input voltage values.
5. A positive injection is induced by $V_{IN} > V_{DD}$ while a negative injection is induced by $V_{IN} < V_{SS}$. $I_{INJ(PIN)}$ must never be exceeded. Refer to [Table 9: Voltage characteristics](#) for the maximum allowed input voltage values.
6. When several inputs are submitted to a current injection, the maximum $\Sigma I_{INJ(PIN)}$ is the absolute sum of the positive and negative injected currents (instantaneous values).

Table 11. Thermal characteristics

| Symbol | Ratings | Value | Unit |
|-----------|------------------------------|-------------|------|
| T_{STG} | Storage temperature range | -65 to +150 | °C |
| T_J | Maximum junction temperature | 150 | °C |

6.3 Operating conditions

6.3.1 General operating conditions

Table 12. General operating conditions

| Symbol | Parameter | Conditions | Min | Max | Unit |
|-----------------|---|--|------|---------------------|------|
| f_{HCLK} | Internal AHB clock frequency | - | 0 | 32 | MHz |
| f_{PCLK1} | Internal APB1 clock frequency | - | 0 | 32 | |
| f_{PCLK2} | Internal APB2 clock frequency | - | 0 | 32 | |
| V_{DD} | Standard operating voltage | BOR detector disabled | 1.65 | 3.6 | V |
| | | BOR detector enabled, at power on | 1.8 | 3.6 | |
| | | BOR detector disabled, after power on | 1.65 | 3.6 | |
| $V_{DDA}^{(1)}$ | Analog operating voltage (ADC and DAC not used) | Must be the same voltage as $V_{DD}^{(2)}$ | 1.65 | 3.6 | V |
| | Analog operating voltage (ADC or DAC used) | | 1.8 | 3.6 | |
| V_{IN} | I/O input voltage | FT pins; $2.0\text{ V} \leq V_{DD}$ | -0.3 | 5.5 ⁽³⁾ | V |
| | | FT pins; $V_{DD} < 2.0\text{ V}$ | -0.3 | 5.25 ⁽³⁾ | |
| | | BOOT0 pin | 0 | 5.5 | |
| | | Any other pin | -0.3 | $V_{DD} + 0.3$ | |
| P_D | Power dissipation at $T_A = 85\text{ °C}$ for suffix 6 or $T_A = 105\text{ °C}$ for suffix 7 ⁽⁴⁾ | LQFP64 package | - | 444 | mW |
| T_A | Ambient temperature for 6 suffix version | Maximum power dissipation ⁽⁵⁾ | -40 | 85 | °C |
| | Ambient temperature for 7 suffix version | Maximum power dissipation | -40 | 105 | |
| T_J | Junction temperature range | 6 suffix version | -40 | 105 | °C |
| | | 7 suffix version | -40 | 110 | |

1. When the ADC is used, refer to [Table 54: ADC characteristics](#).
2. It is recommended to power V_{DD} and V_{DDA} from the same source. A maximum difference of 300 mV between V_{DD} and V_{DDA} can be tolerated during power-up .
3. To sustain a voltage higher than $V_{DD}+0.3V$, the internal pull-up/pull-down resistors must be disabled.
4. If T_A is lower, higher P_D values are allowed as long as T_J does not exceed $T_{J\ max}$ (see [Table 63: Thermal characteristics on page 101](#)).
5. In low-power dissipation state, T_A can be extended to $-40^{\circ}C$ to $105^{\circ}C$ temperature range as long as T_J does not exceed $T_{J\ max}$ (see [Table 63: Thermal characteristics on page 101](#)).

6.3.2 Embedded reset and power control block characteristics

The parameters given in the following table are derived from the tests performed under the conditions summarized in [Table 12](#).

Table 13. Embedded reset and power control block characteristics

| Symbol | Parameter | Conditions | Min | Typ | Max | Unit |
|----------------------|-------------------------------------|--|------|------|----------|-----------|
| $t_{VDD}^{(1)}$ | V_{DD} rise time rate | BOR detector enabled | 0 | - | ∞ | $\mu s/V$ |
| | | BOR detector disabled | 0 | - | 1000 | |
| | V_{DD} fall time rate | BOR detector enabled | 20 | - | ∞ | |
| | | BOR detector disabled | 0 | - | 1000 | |
| $T_{RSTTEMPO}^{(1)}$ | Reset temporization | V_{DD} rising, BOR enabled | - | 2 | 3.3 | ms |
| | | V_{DD} rising, BOR disabled ⁽²⁾ | 0.4 | 0.7 | 1.6 | |
| $V_{POR/PDR}$ | Power on/power down reset threshold | Falling edge | 1 | 1.5 | 1.65 | V |
| | | Rising edge | 1.3 | 1.5 | 1.65 | |
| V_{BOR0} | Brown-out reset threshold 0 | Falling edge | 1.67 | 1.7 | 1.74 | |
| | | Rising edge | 1.69 | 1.76 | 1.8 | |
| V_{BOR1} | Brown-out reset threshold 1 | Falling edge | 1.87 | 1.93 | 1.97 | |
| | | Rising edge | 1.96 | 2.03 | 2.07 | |
| V_{BOR2} | Brown-out reset threshold 2 | Falling edge | 2.22 | 2.30 | 2.35 | |
| | | Rising edge | 2.31 | 2.41 | 2.44 | |

Table 13. Embedded reset and power control block characteristics (continued)

| Symbol | Parameter | Conditions | Min | Typ | Max | Unit |
|-------------------|---|---|------|------|------|------|
| V _{BOR3} | Brown-out reset threshold 3 | Falling edge | 2.45 | 2.55 | 2.6 | V |
| | | Rising edge | 2.54 | 2.66 | 2.7 | |
| V _{BOR4} | Brown-out reset threshold 4 | Falling edge | 2.68 | 2.8 | 2.85 | |
| | | Rising edge | 2.78 | 2.9 | 2.95 | |
| V _{PVD0} | Programmable voltage detector threshold 0 | Falling edge | 1.8 | 1.85 | 1.88 | |
| | | Rising edge | 1.88 | 1.94 | 1.99 | |
| V _{PVD1} | PVD threshold 1 | Falling edge | 1.98 | 2.04 | 2.09 | |
| | | Rising edge | 2.08 | 2.14 | 2.18 | |
| V _{PVD2} | PVD threshold 2 | Falling edge | 2.20 | 2.24 | 2.28 | |
| | | Rising edge | 2.28 | 2.34 | 2.38 | |
| V _{PVD3} | PVD threshold 3 | Falling edge | 2.39 | 2.44 | 2.48 | |
| | | Rising edge | 2.47 | 2.54 | 2.58 | |
| V _{PVD4} | PVD threshold 4 | Falling edge | 2.57 | 2.64 | 2.69 | |
| | | Rising edge | 2.68 | 2.74 | 2.79 | |
| V _{PVD5} | PVD threshold 5 | Falling edge | 2.77 | 2.83 | 2.88 | |
| | | Rising edge | 2.87 | 2.94 | 2.99 | |
| V _{PVD6} | PVD threshold 6 | Falling edge | 2.97 | 3.05 | 3.09 | |
| | | Rising edge | 3.08 | 3.15 | 3.20 | |
| V _{hyst} | Hysteresis voltage | BOR0 threshold | - | 40 | - | mV |
| | | All BOR and PVD thresholds excepting BOR0 | - | 100 | - | |

1. Guaranteed by characterization results.
2. Valid for device version without BOR at power up. Please see option "D" in Ordering information scheme for more details.

6.3.3 Embedded internal reference voltage

The parameters given in [Table 15](#) are based on characterization results, unless otherwise specified.

Table 14. Embedded internal reference voltage calibration values

| Calibration value name | Description | Memory address |
|------------------------|--|---------------------------|
| VREFINT_CAL | Raw data acquired at temperature of 30 °C ±5 °C V _{DDA} = 3 V ±10 mV | 0x1FF8 00F8 - 0x1FF8 00F9 |

Table 15. Embedded internal reference voltage

| Symbol | Parameter | Conditions | Min | Typ | Max | Unit |
|---|---|---|-------|-------|-------|--------------------------|
| V _{REFINT_out} ⁽¹⁾ | Internal reference voltage | -40 °C < T _J < +110 °C | 1.202 | 1.224 | 1.242 | V |
| I _{REFINT} | Internal reference current consumption | - | - | 1.4 | 2.3 | µA |
| T _{VREFINT} | Internal reference startup time | - | - | 2 | 3 | ms |
| V _{VREF_MEAS} | V _{DDA} and V _{REF+} voltage during V _{REFINT} factory measure | - | 2.99 | 3 | 3.01 | V |
| A _{VREF_MEAS} | Accuracy of factory-measured V _{REF} value ⁽²⁾ | Including uncertainties due to ADC and V _{DDA} /V _{REF+} values | - | - | ±5 | mV |
| T _{Coeff} ⁽³⁾ | Temperature coefficient | -40 °C < T _J < +110 °C | - | 25 | 100 | ppm/°C |
| A _{Coeff} ⁽³⁾ | Long-term stability | 1000 hours, T = 25 °C | - | - | 1000 | ppm |
| V _{DDCcoeff} ⁽³⁾ | Voltage coefficient | 3.0 V < V _{DDA} < 3.6 V | - | - | 2000 | ppm/V |
| T _{S_vrefint} ⁽³⁾ | ADC sampling time when reading the internal reference voltage | - | 4 | - | - | µs |
| T _{ADC_BUF} ⁽³⁾ | Startup time of reference voltage buffer for ADC | - | - | - | 10 | µs |
| I _{BUF_ADC} ⁽³⁾ | Consumption of reference voltage buffer for ADC | - | - | 13.5 | 25 | µA |
| I _{VREF_OUT} ⁽³⁾ | VREF_OUT output current ⁽⁴⁾ | - | - | - | 1 | µA |
| C _{VREF_OUT} ⁽³⁾ | VREF_OUT output load | - | - | - | 50 | pF |
| I _{LPBUF} ⁽³⁾ | Consumption of reference voltage buffer for VREF_OUT and COMP | - | - | 730 | 1200 | nA |
| V _{REFINT_DIV1} ⁽³⁾ | 1/4 reference voltage | - | 24 | 25 | 26 | % V _{REFINT} |
| V _{REFINT_DIV2} ⁽³⁾ | 1/2 reference voltage | - | 49 | 50 | 51 | |
| V _{REFINT_DIV3} ⁽³⁾ | 3/4 reference voltage | - | 74 | 75 | 76 | |

1. Guaranteed by test in production.

2. The internal V_{REF} value is individually measured in production and stored in dedicated EEPROM bytes.

3. Guaranteed by characterization results.

4. To guarantee less than 1% VREF_OUT deviation.

6.3.4 Supply current characteristics

The current consumption is a function of several parameters and factors such as the operating voltage, temperature, I/O pin loading, device software configuration, operating frequencies, I/O pin switching rate, program location in memory and executed binary code. The current consumption is measured as described in [Figure 9: Current consumption measurement scheme](#).

All Run-mode current consumption measurements given in this section are performed with a reduced code that gives a consumption equivalent to the Dhrystone 2.1 code, unless otherwise specified. The current consumption values are derived from tests performed under ambient temperature $T_A = 25\text{ }^\circ\text{C}$ and V_{DD} supply voltage conditions summarized in [Table 12: General operating conditions](#), unless otherwise specified.

The MCU is placed under the following conditions:

- All I/O pins are configured in analog input mode
- All peripherals are disabled except when explicitly mentioned.
- The Flash memory access time, 64-bit access and prefetch is adjusted depending on f_{HCLK} frequency and voltage range to provide the best CPU performance.
- When the peripherals are enabled $f_{APB1} = f_{APB2} = f_{AHB}$.
- When PLL is ON, the PLL inputs are equal to HSI = 16 MHz (if internal clock is used) or HSE = 16 MHz (if HSE bypass mode is used).
- The HSE user clock applied to OSCI_IN input follows the characteristic specified in [Table 25: High-speed external user clock characteristics](#).
- For maximum current consumption $V_{DD} = V_{DDA} = 3.6\text{ V}$ is applied to all supply pins.
- For typical current consumption $V_{DD} = V_{DDA} = 3.0\text{ V}$ is applied to all supply pins if not specified otherwise.

Table 16. Current consumption in Run mode, code with data processing running from Flash

| Symbol | Parameter | Conditions | f _{HCLK} | Typ | Max ⁽¹⁾ | Unit | | |
|---|---|---|--|--|--------------------|------|----|-----|
| I _{DD} (Run from Flash) | Supply current in Run mode, code executed from Flash | f _{HSE} = f _{HCLK} up to 16 MHz included, f _{HSE} = f _{HCLK} /2 above 16 MHz (PLL ON) ⁽²⁾ | Range 3, V _{CORE} =1.2 V VOS[1:0] = 11 | 1 MHz | 215 | 400 | μA | |
| | | | | 2 MHz | 400 | 600 | | |
| | | | | 4 MHz | 725 | 960 | | |
| | | | Range 2, V _{CORE} =1.5 V VOS[1:0] = 10 | 4 MHz | 0.915 | 1.1 | mA | |
| | | | | 8 MHz | 1.75 | 2.1 | | |
| | | | | 16 MHz | 3.4 | 3.9 | | |
| | | | | Range 1, V _{CORE} =1.8 V VOS[1:0] = 01 | 8 MHz | 2.1 | | 2.8 |
| | | | | | 16 MHz | 4.2 | | 4.9 |
| | | | | | 32 MHz | 8.25 | | 9.4 |
| | | HSI clock source (16 MHz) | Range 2, V _{CORE} =1.5 V VOS[1:0] = 10 | 16 MHz | 3.5 | 4 | | |
| | | | Range 1, V _{CORE} =1.8 V VOS[1:0] = 01 | 32 MHz | 8.2 | 9.6 | | |
| | | MSI clock, 65 kHz | Range 3, V _{CORE} =1.2 V VOS[1:0] = 11 | 65 kHz | 40.5 | 110 | μA | |
| | | MSI clock, 524 kHz | | 524 kHz | 125 | 190 | | |
| | | MSI clock, 4.2 MHz | | 4.2 MHz | 775 | 900 | | |

1. Guaranteed by characterization results, unless otherwise specified.
2. Oscillator bypassed (HSEBYP = 1 in RCC_CR register).

Table 17. Current consumption in Run mode, code with data processing running from RAM

| Symbol | Parameter | Conditions | f _{HCLK} | Typ | Max ⁽¹⁾ | Unit | |
|--------------------------------|--|---|---|---------|--------------------|--------------------|----|
| I _{DD} (Run from RAM) | Supply current in Run mode, code executed from RAM, Flash switched off | f _{HSE} = f _{HCLK} up to 16 MHz, included f _{HSE} = f _{HCLK} /2 above 16 MHz (PLL ON) ⁽²⁾ | Range 3, V _{CORE} =1.2 V VOS[1:0] = 11 | 1 MHz | 185 | 240 | μA |
| | | | | 2 MHz | 345 | 410 | |
| | | | | 4 MHz | 645 | 880 ⁽³⁾ | |
| | | | Range 2, V _{CORE} =1.5 V VOS[1:0] = 10 | 4 MHz | 0.755 | 1.4 | mA |
| | | | | 8 MHz | 1.5 | 2.1 | |
| | | | | 16 MHz | 3 | 3.5 | |
| | | | Range 1, V _{CORE} =1.8 V VOS[1:0] = 01 | 8 MHz | 1.8 | 2.8 | |
| | | | | 16 MHz | 3.6 | 4.1 | |
| | | | | 32 MHz | 7.15 | 8.3 | |
| | | HSI clock source (16 MHz) | Range 2, V _{CORE} =1.5 V VOS[1:0] = 10 | 16 MHz | 2.95 | 3.5 | |
| | | | Range 1, V _{CORE} =1.8 V VOS[1:0] = 01 | 32 MHz | 7.15 | 8.4 | |
| | | MSI clock, 65 kHz | Range 3, V _{CORE} =1.2 V VOS[1:0] = 11 | 65 kHz | 38.5 | 85 | |
| | | MSI clock, 524 kHz | | 524 kHz | 110 | 160 | |
| | | MSI clock, 4.2 MHz | | 4.2 MHz | 690 | 810 | |

1. Guaranteed by characterization results, unless otherwise specified.
2. Oscillator bypassed (HSEBYP = 1 in RCC_CR register).
3. Guaranteed by test in production.

Table 18. Current consumption in Sleep mode

| Symbol | Parameter | Conditions | f _{HCLK} | Typ | Max ⁽¹⁾ | Unit | | |
|---|---|--|---|---|--------------------|------|----|-----|
| I _{DD} (Sleep) | Supply current in Sleep mode, Flash OFF | f _{HSE} = f _{HCLK} up to 16 MHz included, f _{HSE} = f _{HCLK} /2 above 16 MHz (PLL ON) ⁽²⁾ | Range 3, V _{CORE} =1.2 V VOS[1:0] = 11 | 1 MHz | 50 | 130 | μA | |
| | | | | 2 MHz | 78.5 | 195 | | |
| | | | | 4 MHz | 140 | 310 | | |
| | | | Range 2, V _{CORE} =1.5 V VOS[1:0] = 10 | 4 MHz | 165 | 310 | | |
| | | | | 8 MHz | 310 | 440 | | |
| | | | | 16 MHz | 590 | 830 | | |
| | | | Range 1, V _{CORE} =1.8 V VOS[1:0] = 01 | 8 MHz | 350 | 550 | | |
| | | | | 16 MHz | 680 | 990 | | |
| | | | | 32 MHz | 1600 | 2100 | | |
| | | HSI clock source (16 MHz) | Range 2, V _{CORE} =1.5 V VOS[1:0] = 10 | 16 MHz | 640 | 890 | | |
| | | | Range 1, V _{CORE} =1.8 V VOS[1:0] = 01 | 32 MHz | 1600 | 2200 | | |
| | | | MSI clock, 65 kHz | Range 3, V _{CORE} =1.2 V VOS[1:0] = 11 | 65 kHz | 19 | | 60 |
| | | | MSI clock, 524 kHz | | 524 kHz | 33 | | 99 |
| | | | MSI clock, 4.2 MHz | | 4.2 MHz | 145 | | 210 |
| | Supply current in Sleep mode, Flash ON | f _{HSE} = f _{HCLK} up to 16 MHz included, f _{HSE} = f _{HCLK} /2 above 16 MHz (PLL ON) ⁽²⁾ | Range 3, V _{CORE} =1.2 V VOS[1:0] = 11 | 1 MHz | 60.5 | 130 | | |
| | | | | 2 MHz | 89.5 | 190 | | |
| | | | | 4 MHz | 150 | 320 | | |
| | | | Range 2, V _{CORE} =1.5 V VOS[1:0] = 10 | 4 MHz | 180 | 320 | | |
| | | | | 8 MHz | 320 | 460 | | |
| | | | | 16 MHz | 605 | 840 | | |
| | | | Range 1, V _{CORE} =1.8 V VOS[1:0] = 01 | 8 MHz | 380 | 540 | | |
| | | | | 16 MHz | 695 | 1000 | | |
| | | | | 32 MHz | 1600 | 2100 | | |
| | | HSI clock source (16 MHz) | Range 2, V _{CORE} =1.5 V VOS[1:0] = 10 | 16 MHz | 650 | 910 | | |
| Range 1, V _{CORE} =1.8 V VOS[1:0] = 01 | | | 32 MHz | 1600 | 2200 | | | |
| Supply current in Sleep mode, Flash ON | | | MSI clock, 65 kHz | Range 3, V _{CORE} =1.2V VOS[1:0] = 11 | 65 kHz | 30 | 90 | |
| | | MSI clock, 524 kHz | | 524 kHz | 44 | 96 | | |
| | | MSI clock, 4.2 MHz | | 4.2 MHz | 155 | 220 | | |

1. Guaranteed by characterization results, unless otherwise specified.

2. Oscillator bypassed (HSEBYP = 1 in RCC_CR register)



Table 19. Current consumption in Low-power run mode

| Symbol | Parameter | Conditions | | | Typ | Max ⁽¹⁾ | Unit |
|------------------------------|---|---|---|----------------------------------|-----|--------------------|------|
| I _{DD} (LP Run) | Supply current in Low-power run mode | All peripherals OFF, code executed from RAM, Flash switched OFF, V _{DD} from 1.65 V to 3.6 V | MSI clock, 65 kHz f _{HCLK} = 32 kHz | T _A = -40 °C to 25 °C | 8.6 | 12 | μA |
| | | | | T _A = 85 °C | 19 | 25 | |
| | | | | T _A = 105 °C | 35 | 47 | |
| | | | MSI clock, 65 kHz f _{HCLK} = 65 kHz | T _A = -40 °C to 25 °C | 14 | 16 | |
| | | | | T _A = 85 °C | 24 | 29 | |
| | | | | T _A = 105 °C | 40 | 51 | |
| | | | MSI clock, 131 kHz f _{HCLK} = 131 kHz | T _A = -40 °C to 25 °C | 26 | 29 | |
| | | | | T _A = 55 °C | 28 | 31 | |
| | | | | T _A = 85 °C | 36 | 42 | |
| | | All peripherals OFF, code executed from Flash, V _{DD} from 1.65 V to 3.6 V | MSI clock, 65 kHz f _{HCLK} = 32 kHz | T _A = -40 °C to 25 °C | 20 | 24 | |
| | | | | T _A = 85 °C | 32 | 37 | |
| | | | | T _A = 105 °C | 49 | 61 | |
| | | | MSI clock, 65 kHz f _{HCLK} = 65 kHz | T _A = -40 °C to 25 °C | 26 | 30 | |
| | | | | T _A = 85 °C | 38 | 44 | |
| | | | | T _A = 105 °C | 55 | 67 | |
| | | | MSI clock, 131 kHz f _{HCLK} = 131 kHz | T _A = -40 °C to 25 °C | 41 | 46 | |
| | | | | T _A = 55 °C | 44 | 50 | |
| | | | | T _A = 85 °C | 56 | 87 | |
| | | T _A = 105 °C | 73 | 110 | | | |
| | | | | | | | |
| | | | | | | | |
| I _{DD} max (LP Run) | Max allowed current in Low-power run mode | V _{DD} from 1.65 V to 3.6 V | - | - | - | 200 | |

1. Guaranteed by characterization results, unless otherwise specified.

Table 20. Current consumption in Low-power sleep mode

| Symbol | Parameter | Conditions | | Typ | Max ⁽¹⁾ | Unit | | |
|---|---|---|---|---|----------------------------------|------|----|----|
| I _{DD} (LP Sleep) | Supply current in Low-power sleep mode | All peripherals OFF, V _{DD} from 1.65 V to 3.6 V | MSI clock, 65 kHz f _{HCLK} = 32 kHz Flash OFF | T _A = -40 °C to 25 °C | 4.4 | - | μA | |
| | | | MSI clock, 65 kHz f _{HCLK} = 32 kHz Flash ON | T _A = -40 °C to 25 °C | 14 | 16 | | |
| | | | | T _A = 85 °C | 19 | 23 | | |
| | | | | T _A = 105 °C | 27 | 33 | | |
| | | | MSI clock, 65 kHz f _{HCLK} = 65 kHz, Flash ON | T _A = -40 °C to 25 °C | 15 | 17 | | |
| | | | | T _A = 85 °C | 20 | 23 | | |
| | | | | T _A = 105 °C | 28 | 33 | | |
| | | | MSI clock, 131 kHz f _{HCLK} = 131 kHz, Flash ON | T _A = -40 °C to 25 °C | 17 | 19 | | |
| | | | | T _A = 55 °C | 18 | 21 | | |
| | | | | T _A = 85 °C | 22 | 25 | | |
| | | | TIM9 and USART1 enabled, Flash ON, V _{DD} from 1.65 V to 3.6 V | MSI clock, 65 kHz f _{HCLK} = 32 kHz | T _A = -40 °C to 25 °C | 14 | | 16 |
| | | | | | T _A = 85 °C | 19 | | 22 |
| | | | | | T _A = 105 °C | 27 | | 32 |
| | | | | MSI clock, 65 kHz f _{HCLK} = 65 kHz | T _A = -40 °C to 25 °C | 15 | | 17 |
| | | | | | T _A = 85 °C | 20 | | 23 |
| | | | | | T _A = 105 °C | 28 | | 33 |
| MSI clock, 131 kHz f _{HCLK} = 131 kHz | T _A = -40 °C to 25 °C | 17 | | 19 | | | | |
| | T _A = 55 °C | 18 | | 21 | | | | |
| | T _A = 85 °C | 22 | | 25 | | | | |
| | | T _A = 105 °C | 30 | 36 | | | | |
| | | | | | | | | |
| | | | | | | | | |
| I _{DD} max (LP Sleep) | Max allowed current in Low-power sleep mode | V _{DD} from 1.65 V to 3.6 V | - | - | - | 200 | | |

1. Guaranteed by characterization results, unless otherwise specified.

Table 21. Typical and maximum current consumptions in Stop mode

| Symbol | Parameter | Conditions | | Typ | Max ⁽¹⁾ | Unit | |
|---------------------------------|--|--|-------------------------------------|---|--------------------|------|----|
| I _{DD} (Stop with RTC) | Supply current in Stop mode with RTC enabled | RTC clocked by LSI or LSE external clock (32.768kHz), regulator in LP mode, HSI and HSE OFF (no independent watchdog) | LCD OFF | T _A = -40°C to 25°C V _{DD} = 1.8 V | 1.15 | - | μA |
| | | | | T _A = -40°C to 25°C | 1.4 | - | |
| | | | | T _A = 55°C | 2 | - | |
| | | | | T _A = 85°C | 3.4 | 10 | |
| | | | | T _A = 105°C | 6.35 | 23 | |
| | | | LCD ON (static duty) ⁽²⁾ | T _A = -40°C to 25°C | 1.55 | 6 | |
| | | | | T _A = 55°C | 2.15 | 7 | |
| | | | | T _A = 85°C | 3.55 | 12 | |
| | | | | T _A = 105°C | 6.3 | 27 | |
| | | | LCD ON (1/8 duty) ⁽³⁾ | T _A = -40°C to 25°C | 3.9 | 10 | |
| | | | | T _A = 55°C | 4.65 | 11 | |
| | | | | T _A = 85°C | 6.25 | 16 | |
| | T _A = 105°C | 9.1 | | 44 | | | |
| | Supply current in Stop mode with RTC enabled | RTC clocked by LSE external quartz (32.768kHz), regulator in LP mode, HSI and HSE OFF (no independent watchdog) ⁽⁴⁾ | LCD OFF | T _A = -40°C to 25°C | 1.5 | - | |
| | | | | T _A = 55°C | 2.15 | - | |
| | | | | T _A = 85°C | 3.7 | - | |
| | | | | T _A = 105°C | 6.75 | - | |
| | | | LCD ON (static duty) ⁽²⁾ | T _A = -40°C to 25°C | 1.6 | - | |
| | | | | T _A = 55°C | 2.3 | - | |
| | | | | T _A = 85°C | 3.8 | - | |
| | | | | T _A = 105°C | 6.85 | - | |
| | | | LCD ON (1/8 duty) ⁽³⁾ | T _A = -40°C to 25°C | 4 | - | |
| | | | | T _A = 55°C | 4.85 | - | |
| | | | | T _A = 85°C | 6.5 | - | |
| T _A = 105°C | | | | 9.1 | - | | |
| LCD OFF | T _A = -40°C to 25°C V _{DD} = 1.8V | 1.2 | - | | | | |
| | T _A = -40°C to 25°C V _{DD} = 3.0V | 1.5 | - | | | | |
| | T _A = -40°C to 25°C V _{DD} = 3.6V | 1.75 | - | | | | |

Table 21. Typical and maximum current consumptions in Stop mode (continued)

| Symbol | Parameter | Conditions | | Typ | Max ⁽¹⁾ | Unit |
|--------------------------------|---|---|--------------------------------|-------------------|--------------------|------|
| I _{DD} (Stop) | Supply current in Stop mode (RTC disabled) | Regulator in LP mode, HSI and HSE OFF, independent watchdog and LSI enabled | T _A = -40°C to 25°C | 1.8 | 2.2 | μA |
| | | | T _A = -40°C to 25°C | 0.435 | 1 | |
| | | Regulator in LP mode, LSI, HSI and HSE OFF (no independent watchdog) | T _A = 55°C | 0.99 | 3 | |
| | | | T _A = 85°C | 2.4 | 9 | |
| | | T _A = 105°C | 5.5 | 22 ⁽⁵⁾ | | |
| I _{DD} (WU from Stop) | Supply current during wakeup from Stop mode | MSI = 4.2 MHz | T _A = -40°C to 25°C | 2 | - | mA |
| | | MSI = 1.05 MHz | | 1.45 | - | |
| | | MSI = 65 kHz ⁽⁶⁾ | | 1.45 | - | |

1. Guaranteed by characterization results, unless otherwise specified.
2. LCD enabled with external VLCD, static duty, division ratio = 256, all pixels active, no LCD connected.
3. LCD enabled with external VLCD, 1/8 duty, 1/3 bias, division ratio = 64, all pixels active, no LCD connected.
4. Based on characterization done with a 32.768 kHz crystal (MC306-G-06Q-32.768, manufacturer JFVNY) with two 6.8 pF loading capacitors.
5. Guaranteed by test in production.
6. When MSI = 64 kHz, the RMS current is measured over the first 15 μs following the wakeup event. For the remaining part of the wakeup period, the current corresponds the Run mode current.



Table 22. Typical and maximum current consumptions in Standby mode

| Symbol | Parameter | Conditions | Typ | Max ⁽¹⁾ | Unit | |
|---------------------------------------|---|---|---|----------------------------------|--------------------|-----|
| I _{DD} (Standby with RTC) | Supply current in Standby mode with RTC enabled | RTC clocked by LSI (no independent watchdog) | T _A = -40 °C to 25 °C V _{DD} = 1.8 V | 0.905 | - | μA |
| | | | T _A = -40 °C to 25 °C | 1.15 | 1.9 | |
| | | | T _A = 55 °C | 1.5 | 2.2 | |
| | | | T _A = 85 °C | 1.75 | 4 | |
| | | | T _A = 105 °C | 2.1 | 8.3 ⁽²⁾ | |
| | | RTC clocked by LSE external quartz (no independent watchdog) ⁽³⁾ | T _A = -40 °C to 25 °C V _{DD} = 1.8 V | 0.98 | - | |
| | | | T _A = -40 °C to 25 °C | 1.3 | - | |
| | | | T _A = 55 °C | 1.7 | - | |
| | | | T _A = 85 °C | 2.05 | - | |
| | | | T _A = 105 °C | 2.45 | - | |
| I _{DD} (Standby) | Supply current in Standby mode (RTC disabled) | Independent watchdog and LSI enabled | T _A = -40 °C to 25 °C | 1 | 1.7 | |
| | | | Independent watchdog and LSI OFF | T _A = -40 °C to 25 °C | 0.29 | 0.6 |
| | | T _A = 55 °C | | 0.345 | 0.9 | |
| | | T _A = 85 °C | | 0.575 | 2.75 | |
| | | T _A = 105 °C | | 1.45 | 7 ⁽²⁾ | |
| I _{DD} (WU from Standby) | Supply current during wakeup time from Standby mode | - | T _A = -40 °C to 25 °C | 1 | - | mA |

1. Guaranteed by characterization results, unless otherwise specified.
2. Guaranteed by test in production.
3. Based on characterization done with a 32.768 kHz crystal (MC306-G-06Q-32.768, manufacturer JFVNY) with two 6.8pF loading capacitors.

On-chip peripheral current consumption

The current consumption of the on-chip peripherals is given in the following table. The MCU is placed under the following conditions:

- all I/O pins are in input mode with a static value at V_{DD} or V_{SS} (no load)
- all peripherals are disabled unless otherwise mentioned
- the given value is calculated by measuring the current consumption
 - with all peripherals clocked off
 - with only one peripheral clocked on



Table 23. Peripheral current consumption⁽¹⁾

| Peripheral | | Typical consumption, V _{DD} = 3.0 V, T _A = 25 °C | | | | Unit |
|------------|--------|--|--|--|-------------------------------|--------------------------------|
| | | Range 1, V _{CORE} = 1.8 V VOS[1:0] = 01 | Range 2, V _{CORE} = 1.5 V VOS[1:0] = 10 | Range 3, V _{CORE} = 1.2 V VOS[1:0] = 11 | Low-power sleep and run | |
| APB1 | TIM2 | 11.2 | 8.9 | 7.0 | 8.9 | μA/MHz (f _{HCLK}) |
| | TIM3 | 11.2 | 9.0 | 7.1 | 9.0 | |
| | TIM4 | 12.9 | 10.4 | 8.2 | 10.4 | |
| | TIM5 | 14.4 | 11.5 | 9.0 | 11.5 | |
| | TIM6 | 4.0 | 3.1 | 2.4 | 3.1 | |
| | TIM7 | 3.8 | 3.0 | 2.3 | 3.0 | |
| | LCD | 5.8 | 4.6 | 3.6 | 4.6 | |
| | WWDG | 2.9 | 2.3 | 1.8 | 2.3 | |
| | SPI2 | 6.5 | 5.2 | 4.1 | 5.2 | |
| | SPI3 | 5.9 | 4.6 | 3.6 | 4.6 | |
| | USART2 | 8.8 | 7.0 | 5.5 | 7.0 | |
| | USART3 | 8.4 | 6.8 | 5.3 | 6.8 | |
| | I2C1 | 7.3 | 5.8 | 4.6 | 5.8 | |
| | I2C2 | 7.9 | 6.3 | 5.0 | 6.3 | |
| | USB | 13.3 | 10.6 | 8.3 | 10.6 | |
| | PWR | 2.8 | 2.2 | 1.8 | 2.2 | |
| | DAC | 6.1 | 4.9 | 3.9 | 4.9 | |
| COMP | 4.8 | 3.8 | 3.0 | 3.8 | | |

Table 23. Peripheral current consumption⁽¹⁾ (continued)

| Peripheral | | Typical consumption, V _{DD} = 3.0 V, T _A = 25 °C | | | | Unit |
|--|--------------------|--|--|--|-------------------------------|--------------------------------|
| | | Range 1, V _{CORE} = 1.8 V VOS[1:0] = 01 | Range 2, V _{CORE} = 1.5 V VOS[1:0] = 10 | Range 3, V _{CORE} = 1.2 V VOS[1:0] = 11 | Low-power sleep and run | |
| APB2 | SYSCFG & RI | 2.6 | 2.0 | 1.6 | 2.0 | μA/MHz (f _{HCLK}) |
| | TIM9 | 7.9 | 6.4 | 5.0 | 6.4 | |
| | TIM10 | 5.9 | 4.7 | 3.8 | 4.7 | |
| | TIM11 | 5.9 | 4.6 | 3.7 | 4.6 | |
| | ADC ⁽²⁾ | 10.5 | 8.3 | 6.6 | 8.3 | |
| | SPI1 | 4.3 | 3.4 | 2.8 | 3.4 | |
| | USART1 | 8.8 | 7.1 | 5.6 | 7.1 | |
| AHB | GPIOA | 4.3 | 3.3 | 2.6 | 3.3 | |
| | GPIOB | 4.3 | 3.5 | 2.8 | 3.5 | |
| | GPIOC | 4.0 | 3.2 | 2.5 | 3.2 | |
| | GPIOD | 4.1 | 3.3 | 2.5 | 3.3 | |
| | GPIOE | 4.2 | 3.4 | 2.7 | 3.4 | |
| | GPIOH | 3.7 | 3.0 | 2.3 | 3.0 | |
| | CRC | 0.8 | 0.6 | 0.5 | 0.6 | |
| | FLASH | 11.1 | 9.4 | 8 | _(3) | |
| | DMA1 | 15.6 | 12.7 | 10 | 12.7 | |
| | DMA2 | 16.3 | 13.4 | 10.5 | 13.4 | |
| All enabled | | 187 | 154 | 120 | 144.6 | |
| I _{DD} (RTC) | | 0.4 | | | | μA |
| I _{DD} (LCD) | | 3.1 | | | | |
| I _{DD} (ADC) ⁽⁴⁾ | | 1450 | | | | |
| I _{DD} (DAC) ⁽⁵⁾ | | 340 | | | | |
| I _{DD} (COMP1) | | 0.16 | | | | |
| I _{DD} (COMP2) | Slow mode | 2 | | | | |
| | Fast mode | 5 | | | | |
| I _{DD} (PVD / BOR) ⁽⁶⁾ | | 2.6 | | | | |
| I _{DD} (IWDG) | | 0.25 | | | | |

1. Data based on differential I_{DD} measurement between all peripherals OFF an one peripheral with clock enabled, in the following conditions: f_{HCLK} = 32 MHz (range 1), f_{HCLK} = 16 MHz (range 2), f_{HCLK} = 4 MHz (range 3), f_{HCLK} = 64kHz (Low-power run/sleep), f_{APB1} = f_{HCLK}, f_{APB2} = f_{HCLK}, default prescaler value for each peripheral. The CPU is in Sleep mode in both cases. No I/O pins toggling.

2. HSI oscillator is OFF for this measure.



3. In Low-power sleep and run mode, the Flash memory must always be in power-down mode.
4. Data based on a differential I_{DD} measurement between ADC in reset configuration and continuous ADC conversion (HSI consumption not included).
5. Data based on a differential I_{DD} measurement between DAC in reset configuration and continuous DAC conversion of V_{DD}/2. DAC is in buffered mode, output is left floating.
6. Including supply current of internal reference voltage.

6.3.5 Wakeup time from low-power mode

The wakeup times given in the following table are measured with the MSI RC oscillator. The clock source used to wake up the device depends on the current operating mode:

- Sleep mode: the clock source is the clock that was set before entering Sleep mode
- Stop mode: the clock source is the MSI oscillator in the range configured before entering Stop mode
- Standby mode: the clock source is the MSI oscillator running at 2.1 MHz

All timings are derived from tests performed under the conditions summarized in [Table 12](#).

Table 24. Low-power mode wakeup timings

| Symbol | Parameter | Conditions | Typ | Max ⁽¹⁾ | Unit |
|----------------------------------|---|---|------|--------------------|------|
| t _{WUSLEEP} | Wakeup from Sleep mode | f _{HCLK} = 32 MHz | 0.4 | - | μs |
| t _{WUSLEEP_LP} | Wakeup from Low-power sleep mode, f _{HCLK} = 262 kHz | f _{HCLK} = 262 kHz Flash enabled | 46 | - | |
| | | f _{HCLK} = 262 kHz Flash switched OFF | 46 | - | |
| t _{WUSTOP} | Wakeup from Stop mode, regulator in Run mode ULP bit = 1 and FWU bit = 1 | f _{HCLK} = f _{MSI} = 4.2 MHz | 8.2 | - | |
| | Wakeup from Stop mode, regulator in low-power mode ULP bit = 1 and FWU bit = 1 | f _{HCLK} = f _{MSI} = 4.2 MHz Voltage range 1 and 2 | 7.7 | 8.9 | |
| | | f _{HCLK} = f _{MSI} = 4.2 MHz Voltage range 3 | 8.2 | 13.1 | |
| | | f _{HCLK} = f _{MSI} = 2.1 MHz | 10.2 | 13.4 | |
| | | f _{HCLK} = f _{MSI} = 1.05 MHz | 16 | 20 | |
| | | f _{HCLK} = f _{MSI} = 524 kHz | 31 | 37 | |
| | | f _{HCLK} = f _{MSI} = 262 kHz | 57 | 66 | |
| | | f _{HCLK} = f _{MSI} = 131 kHz | 112 | 123 | |
| f _{HCLK} = MSI = 65 kHz | 221 | 236 | | | |
| t _{WUSTDBY} | Wakeup from Standby mode ULP bit = 1 and FWU bit = 1 | f _{HCLK} = MSI = 2.1 MHz | 58 | 104 | |
| | Wakeup from Standby mode FWU bit = 0 | f _{HCLK} = MSI = 2.1 MHz | 2.6 | 3.25 | ms |

1. Guaranteed by characterization, unless otherwise specified



6.3.6 External clock source characteristics

High-speed external user clock generated from an external source

In bypass mode the HSE oscillator is switched off and the input pin is a standard GPIO. The external clock signal has to respect the I/O characteristics in [Section 6.3.12](#). However, the recommended clock input waveform is shown in [Figure 10](#).

Table 25. High-speed external user clock characteristics⁽¹⁾

| Symbol | Parameter | Conditions | Min | Typ | Max | Unit |
|--------------------------------|--------------------------------------|--------------------------|-------------|-----|-------------|------|
| f_{HSE_ext} | User external clock source frequency | CSS is on or PLL is used | 1 | 8 | 32 | MHz |
| | | CSS is off, PLL not used | 0 | 8 | 32 | MHz |
| V_{HSEH} | OSC_IN input pin high level voltage | - | $0.7V_{DD}$ | - | V_{DD} | V |
| V_{HSEL} | OSC_IN input pin low level voltage | | V_{SS} | - | $0.3V_{DD}$ | |
| $t_{w(HSEH)}$ $t_{w(HSEL)}$ | OSC_IN high or low time | | 12 | - | - | ns |
| $t_r(HSE)$ $t_f(HSE)$ | OSC_IN rise or fall time | | - | - | 20 | |
| $C_{in(HSE)}$ | OSC_IN input capacitance | | - | 2.6 | - | pF |

1. Guaranteed by design.

Figure 10. High-speed external clock source AC timing diagram

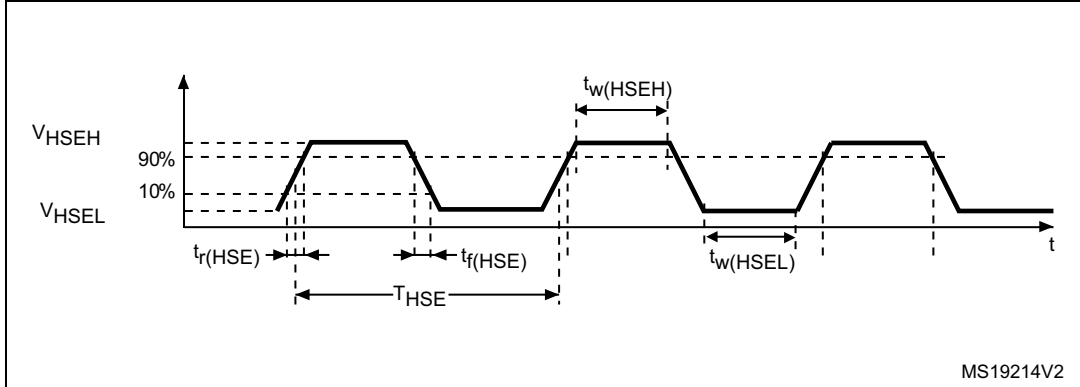

Low-speed external user clock generated from an external source

The characteristics given in the following table result from tests performed using a low-speed external clock source, and under the conditions summarized in [Table 12](#).

Table 26. Low-speed external user clock characteristics⁽¹⁾

| Symbol | Parameter | Conditions | Min | Typ | Max | Unit |
|--------------------------------|---------------------------------------|------------|-------------|--------|-------------|------|
| f_{LSE_ext} | User external clock source frequency | | 1 | 32.768 | 1000 | kHz |
| V_{LSEH} | OSC32_IN input pin high level voltage | - | $0.7V_{DD}$ | - | V_{DD} | V |
| V_{LSEL} | OSC32_IN input pin low level voltage | | V_{SS} | - | $0.3V_{DD}$ | |
| $t_{w(LSEH)}$ $t_{w(LSEL)}$ | OSC32_IN high or low time | | 465 | - | - | ns |
| $t_{r(LSE)}$ $t_{f(LSE)}$ | OSC32_IN rise or fall time | - | - | 10 | | |
| $C_{IN(LSE)}$ | OSC32_IN input capacitance | - | - | 0.6 | - | pF |

1. Guaranteed by design.

Figure 11. Low-speed external clock source AC timing diagram

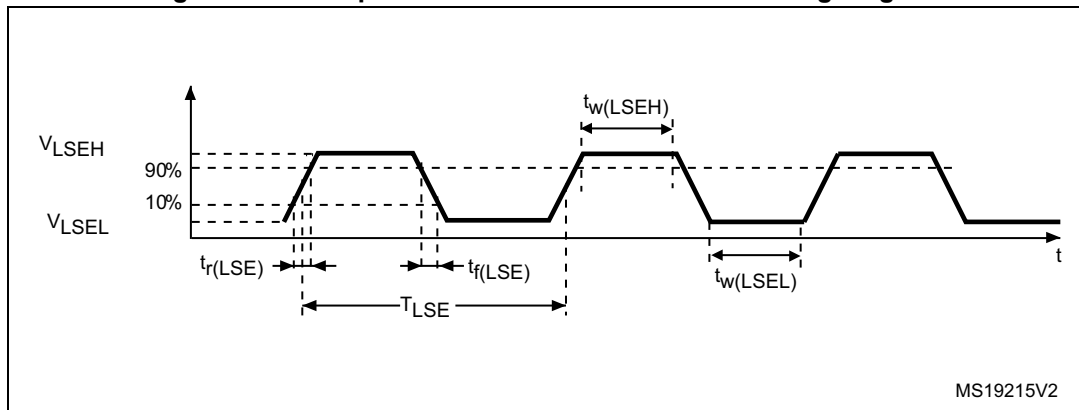

High-speed external clock generated from a crystal/ceramic resonator

The high-speed external (HSE) clock can be supplied with a 1 to 24 MHz crystal/ceramic resonator oscillator. All the information given in this paragraph are based on characterization results obtained with typical external components specified in [Table 27](#). In the application, the resonator and the load capacitors have to be placed as close as possible to the oscillator pins in order to minimize output distortion and startup stabilization time. Refer to the crystal resonator manufacturer for more details on the resonator characteristics (frequency, package, accuracy).

Table 27. HSE oscillator characteristics⁽¹⁾⁽²⁾

| Symbol | Parameter | Conditions | Min | Typ | Max | Unit |
|-------------------------------------|--|---|-----|-----|------------------------------------|------|
| f _{OSC_IN} | Oscillator frequency | - | 1 | | 24 | MHz |
| R _F | Feedback resistor | - | - | 200 | - | kΩ |
| C | Recommended load capacitance versus equivalent serial resistance of the crystal (R _S) ⁽³⁾ | R _S = 30 Ω | - | 20 | - | pF |
| I _{HSE} | HSE driving current | V _{DD} = 3.3 V, V _{IN} = V _{SS} with 30 pF load | - | - | 3 | mA |
| I _{DD(HSE)} | HSE oscillator power consumption | C = 20 pF f _{OSC} = 16 MHz | - | - | 2.5 (startup) 0.7 (stabilized) | mA |
| | | C = 10 pF f _{OSC} = 16 MHz | - | - | 2.5 (startup) 0.46 (stabilized) | |
| g _m | Oscillator transconductance | Startup | 3.5 | - | - | mA/V |
| t _{SU(HSE)} ⁽⁴⁾ | Startup time | V _{DD} is stabilized | - | 1 | - | ms |

1. Resonator characteristics given by the crystal/ceramic resonator manufacturer.
2. Guaranteed by characterization results.
3. The relatively low value of the RF resistor offers a good protection against issues resulting from use in a humid environment, due to the induced leakage and the bias condition change. However, it is recommended to take this point into account if the MCU is used in tough humidity conditions.
4. t_{SU(HSE)} is the startup time measured from the moment it is enabled (by software) to a stabilized 8 MHz oscillation is reached. This value is measured for a standard crystal resonator and it can vary significantly with the crystal manufacturer.

For C_{L1} and C_{L2}, it is recommended to use high-quality external ceramic capacitors in the 5 pF to 25 pF range (typ.), designed for high-frequency applications, and selected to match the requirements of the crystal or resonator (see [Figure 12](#)). C_{L1} and C_{L2} are usually the same size. The crystal manufacturer typically specifies a load capacitance which is the series combination of C_{L1} and C_{L2}. PCB and MCU pin capacitance must be included (10 pF can be used as a rough estimate of the combined pin and board capacitance) when sizing C_{L1} and C_{L2}. Refer to the application note AN2867 “Oscillator design guide for ST microcontrollers” available from the ST website www.st.com.

Figure 12. HSE oscillator circuit diagram

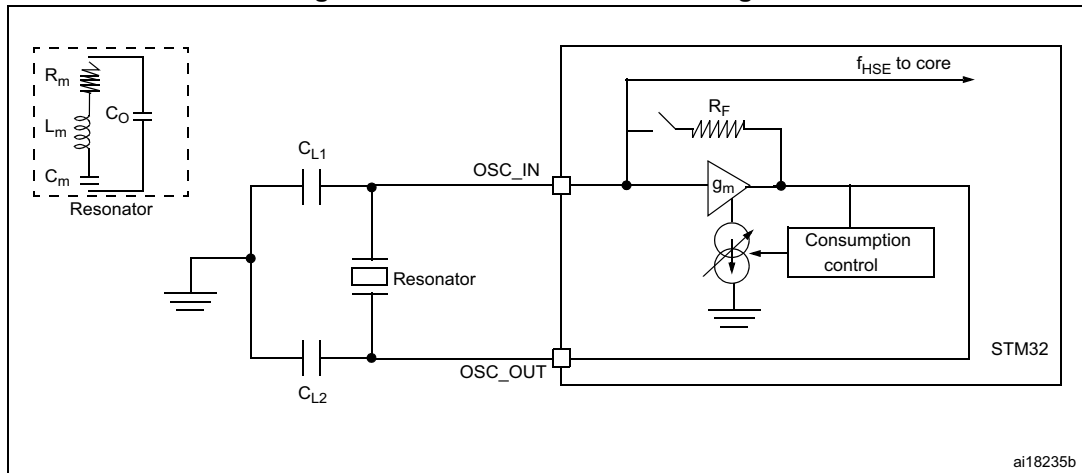

Low-speed external clock generated from a crystal/ceramic resonator

The low-speed external (LSE) clock can be supplied with a 32.768 kHz crystal/ceramic resonator oscillator. All the information given in this paragraph are based on characterization results obtained with typical external components specified in [Table 28](#). In the application, the resonator and the load capacitors have to be placed as close as possible to the oscillator pins in order to minimize output distortion and startup stabilization time. Refer to the crystal resonator manufacturer for more details on the resonator characteristics (frequency, package, accuracy).

Table 28. LSE oscillator characteristics ($f_{LSE} = 32.768 \text{ kHz}$)⁽¹⁾

| Symbol | Parameter | Conditions | Min | Typ | Max | Unit |
|------------------------|--|---|-----|--------|-----|------|
| f_{LSE} | Low speed external oscillator frequency | - | - | 32.768 | - | kHz |
| R_F | Feedback resistor | - | - | 1.2 | - | MΩ |
| $C^{(2)}$ | Recommended load capacitance versus equivalent serial resistance of the crystal (R_S) ⁽³⁾ | $R_S = 30 \text{ k}\Omega$ | - | 8 | - | pF |
| I_{LSE} | LSE driving current | $V_{DD} = 3.3 \text{ V}, V_{IN} = V_{SS}$ | - | - | 1.1 | μA |
| $I_{DD} \text{ (LSE)}$ | LSE oscillator current consumption | $V_{DD} = 1.8 \text{ V}$ | - | 450 | - | nA |
| | | $V_{DD} = 3.0 \text{ V}$ | - | 600 | - | |
| | | $V_{DD} = 3.6 \text{ V}$ | - | 750 | - | |
| g_m | Oscillator transconductance | - | 3 | - | - | μA/V |
| $t_{SU(LSE)}^{(4)}$ | Startup time | V_{DD} is stabilized | - | 1 | - | s |

1. Guaranteed by characterization results.
2. Refer to the note and caution paragraphs below the table, and to the application note AN2867 "Oscillator design guide for ST microcontrollers".
3. The oscillator selection can be optimized in terms of supply current using an high quality resonator with small R_S value for example MSIV-TIN32.768kHz. Refer to crystal manufacturer for more details.
4. $t_{SU(LSE)}$ is the startup time measured from the moment it is enabled (by software) to a stabilized 32.768 kHz oscillation is reached. This value is measured for a standard crystal resonator and it can vary significantly with the crystal manufacturer.

Note: For C_{L1} and C_{L2} , it is recommended to use high-quality ceramic capacitors in the 5 pF to 15 pF range selected to match the requirements of the crystal or resonator (see Figure 13). C_{L1} and C_{L2} are usually the same size. The crystal manufacturer typically specifies a load capacitance which is the series combination of C_{L1} and C_{L2} . Load capacitance C_L has the following formula: $C_L = C_{L1} \times C_{L2} / (C_{L1} + C_{L2}) + C_{stray}$ where C_{stray} is the pin capacitance and board or trace PCB-related capacitance. Typically, it is between 2 pF and 7 pF.

Caution: To avoid exceeding the maximum value of C_{L1} and C_{L2} (15 pF) it is strongly recommended to use a resonator with a load capacitance $C_L \leq 7$ pF. Never use a resonator with a load capacitance of 12.5 pF.

Example: if the user chooses a resonator with a load capacitance of $C_L = 6$ pF and $C_{stray} = 2$ pF, then $C_{L1} = C_{L2} = 8$ pF.

Figure 13. Typical application with a 32.768 kHz crystal

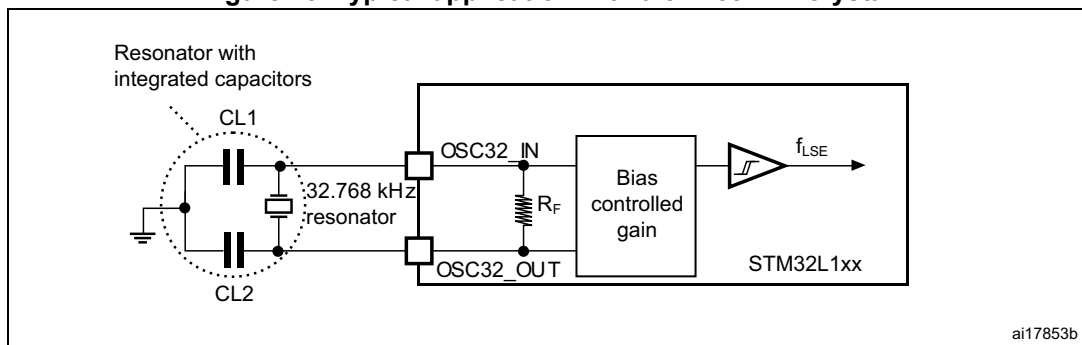

6.3.7 Internal clock source characteristics

The parameters given in [Table 29](#) are derived from tests performed under the conditions summarized in [Table 12](#).

High-speed internal (HSI) RC oscillator

Table 29. HSI oscillator characteristics

| Symbol | Parameter | Conditions | Min | Typ | Max | Unit |
|---------------------------------|---|--|-------------------|-----------|------------------|---------------|
| f_{HSI} | Frequency | $V_{\text{DD}} = 3.0 \text{ V}$ | - | 16 | - | MHz |
| $\text{TRIM}^{(1)(2)}$ | HSI user-trimmed resolution | Trimming code is not a multiple of 16 | - | ± 0.4 | 0.7 | % |
| | | Trimming code is a multiple of 16 | - | - | ± 1.5 | % |
| $\text{ACC}_{\text{HSI}}^{(2)}$ | Accuracy of the factory-calibrated HSI oscillator | $V_{\text{DDA}} = 3.0 \text{ V}, T_{\text{A}} = 25 \text{ }^\circ\text{C}$ | -1 ⁽³⁾ | - | 1 ⁽³⁾ | % |
| | | $V_{\text{DDA}} = 3.0 \text{ V}, T_{\text{A}} = 0 \text{ to } 55 \text{ }^\circ\text{C}$ | -1.5 | - | 1.5 | % |
| | | $V_{\text{DDA}} = 3.0 \text{ V}, T_{\text{A}} = -10 \text{ to } 70 \text{ }^\circ\text{C}$ | -2 | - | 2 | % |
| | | $V_{\text{DDA}} = 3.0 \text{ V}, T_{\text{A}} = -10 \text{ to } 85 \text{ }^\circ\text{C}$ | -2.5 | - | 2 | % |
| | | $V_{\text{DDA}} = 3.0 \text{ V}, T_{\text{A}} = -10 \text{ to } 105 \text{ }^\circ\text{C}$ | -4 | - | 2 | % |
| | | $V_{\text{DDA}} = 1.65 \text{ V to } 3.6 \text{ V}$ $T_{\text{A}} = -40 \text{ to } 105 \text{ }^\circ\text{C}$ | -4 | - | 3 | % |
| $t_{\text{SU(HSI)}}^{(2)}$ | HSI oscillator startup time | - | - | 3.7 | 6 | μs |
| $I_{\text{DD(HSI)}}^{(2)}$ | HSI oscillator power consumption | - | - | 100 | 140 | μA |

1. The trimming step differs depending on the trimming code. It is usually negative on the codes which are multiples of 16 (0x00, 0x10, 0x20, 0x30...0xE0).
2. Guaranteed by characterization results.
3. Guaranteed by test in production.

Low-speed internal (LSI) RC oscillator

Table 30. LSI oscillator characteristics

| Symbol | Parameter | Min | Typ | Max | Unit |
|----------------------------|--|-----|-----|-----|---------------|
| $f_{\text{LSI}}^{(1)}$ | LSI frequency | 26 | 38 | 56 | kHz |
| $D_{\text{LSI}}^{(2)}$ | LSI oscillator frequency drift $0^\circ\text{C} \leq T_{\text{A}} \leq 105^\circ\text{C}$ | -10 | - | 4 | % |
| $t_{\text{SU(LSI)}}^{(3)}$ | LSI oscillator startup time | - | - | 200 | μs |
| $I_{\text{DD(LSI)}}^{(3)}$ | LSI oscillator power consumption | - | 400 | 510 | nA |

1. Guaranteed by test in production.
2. This is a deviation for an individual part, once the initial frequency has been measured.
3. Guaranteed by design.

Multi-speed internal (MSI) RC oscillator

Table 31. MSI oscillator characteristics

| Symbol | Parameter | Condition | Typ | Max | Unit |
|-----------------------|--|--|-----------|-----|---------------|
| f_{MSI} | Frequency after factory calibration, done at $V_{DD} = 3.3\text{ V}$ and $T_A = 25\text{ °C}$ | MSI range 0 | 65.5 | - | kHz |
| | | MSI range 1 | 131 | - | |
| | | MSI range 2 | 262 | - | |
| | | MSI range 3 | 524 | - | MHz |
| | | MSI range 4 | 1.05 | - | |
| | | MSI range 5 | 2.1 | - | |
| | | MSI range 6 | 4.2 | - | |
| ACC_{MSI} | Frequency error after factory calibration | - | ± 0.5 | - | % |
| $D_{TEMP(MSI)}^{(1)}$ | MSI oscillator frequency drift $0\text{ °C} \leq T_A \leq 105\text{ °C}$ | - | ± 3 | - | % |
| $D_{VOLT(MSI)}^{(1)}$ | MSI oscillator frequency drift $1.65\text{ V} \leq V_{DD} \leq 3.6\text{ V}$, $T_A = 25\text{ °C}$ | - | - | 2.5 | %/V |
| $I_{DD(MSI)}^{(2)}$ | MSI oscillator power consumption | MSI range 0 | 0.75 | - | μA |
| | | MSI range 1 | 1 | - | |
| | | MSI range 2 | 1.5 | - | |
| | | MSI range 3 | 2.5 | - | |
| | | MSI range 4 | 4.5 | - | |
| | | MSI range 5 | 8 | - | |
| | | MSI range 6 | 15 | - | |
| $t_{SU(MSI)}$ | MSI oscillator startup time | MSI range 0 | 30 | - | μs |
| | | MSI range 1 | 20 | - | |
| | | MSI range 2 | 15 | - | |
| | | MSI range 3 | 10 | - | |
| | | MSI range 4 | 6 | - | |
| | | MSI range 5 | 5 | - | |
| | | MSI range 6, Voltage range 1 and 2 | 3.5 | - | |
| | | MSI range 6, Voltage range 3 | 5 | - | |

Table 31. MSI oscillator characteristics (continued)

| Symbol | Parameter | Condition | Typ | Max | Unit |
|------------------------------|------------------------------------|--|-----|-----|---------------|
| $t_{\text{STAB(MSI)}}^{(2)}$ | MSI oscillator stabilization time | MSI range 0 | - | 40 | μs |
| | | MSI range 1 | - | 20 | |
| | | MSI range 2 | - | 10 | |
| | | MSI range 3 | - | 4 | |
| | | MSI range 4 | - | 2.5 | |
| | | MSI range 5 | - | 2 | |
| | | MSI range 6, Voltage range 1 and 2 | - | 2 | |
| $f_{\text{OVER(MSI)}}$ | MSI oscillator frequency overshoot | Any range to range 5 | - | 4 | MHz |
| | | Any range to range 6 | - | 6 | |

1. This is a deviation for an individual part, once the initial frequency has been measured.
2. Guaranteed by characterization results.

6.3.8 PLL characteristics

The parameters given in [Table 32](#) are derived from tests performed under the conditions summarized in [Table 12](#).

Table 32. PLL characteristics

| Symbol | Parameter | Value | | | Unit |
|------------------------|---|-------|-----|--------------------|------|
| | | Min | Typ | Max ⁽¹⁾ | |
| f _{PLL_IN} | PLL input clock ⁽²⁾ | 2 | - | 24 | MHz |
| | PLL input clock duty cycle | 45 | - | 55 | % |
| f _{PLL_OUT} | PLL output clock | 2 | - | 32 | MHz |
| t _{LOCK} | PLL lock time PLL input = 16 MHz PLL VCO = 96 MHz | - | 115 | 160 | μs |
| Jitter | Cycle-to-cycle jitter | - | - | ±600 | ps |
| I _{DDA} (PLL) | Current consumption on V _{DDA} | - | 220 | 450 | μA |
| I _{DD} (PLL) | Current consumption on V _{DD} | - | 120 | 150 | |

1. Guaranteed by characterization results.
2. Take care of using the appropriate multiplier factors so as to have PLL input clock values compatible with the range defined by f_{PLL_OUT}.

6.3.9 Memory characteristics

The characteristics are given at T_A = -40 to 105 °C unless otherwise specified.

RAM memory

Table 33. RAM and hardware registers

| Symbol | Parameter | Conditions | Min | Typ | Max | Unit |
|--------|------------------------------------|----------------------|------|-----|-----|------|
| VRM | Data retention mode ⁽¹⁾ | STOP mode (or RESET) | 1.65 | - | - | V |

1. Minimum supply voltage without losing data stored in RAM (in Stop mode or under Reset) or in hardware registers (only in Stop mode).

Flash memory and data EEPROM

Table 34. Flash memory and data EEPROM characteristics

| Symbol | Parameter | Conditions | Min | Typ | Max ⁽¹⁾ | Unit |
|-------------------|--|---|------|------|--------------------|------|
| V _{DD} | Operating voltage Read / Write / Erase | - | 1.65 | - | 3.6 | V |
| t _{prog} | Programming/ erasing time for byte / word / double word / half-page | Erasing | - | 3.28 | 3.94 | ms |
| | | Programming | - | 3.28 | 3.94 | |
| I _{DD} | Average current during the whole programming / erase operation | T _A = 25 °C, V _{DD} = 3.6 V | - | 600 | | µA |
| | Maximum current (peak) during the whole programming / erase operation | | - | 1.5 | 2.5 | mA |

1. Guaranteed by design.

Table 35. Flash memory and data EEPROM endurance and retention

| Symbol | Parameter | Conditions | Value | | | Unit |
|---------------------------------|---|-------------------------------------|--------------------|-----|-----|---------|
| | | | Min ⁽¹⁾ | Typ | Max | |
| N _{CYC} ⁽²⁾ | Cycling (erase / write) Program memory | T _A = -40°C to 105 °C | 10 | - | - | kcycles |
| | Cycling (erase / write) EEPROM data memory | | 300 | - | - | |
| t _{RET} ⁽²⁾ | Data retention (program memory) after 10 kcycles at T _A = 85 °C | T _{RET} = +85 °C | 30 | - | - | years |
| | Data retention (EEPROM data memory) after 300 kcycles at T _A = 85 °C | | 30 | - | - | |
| | Data retention (program memory) after 10 kcycles at T _A = 105 °C | T _{RET} = +105 °C | 10 | - | - | |
| | Data retention (EEPROM data memory) after 300 kcycles at T _A = 105 °C | | 10 | - | - | |

1. Guaranteed by characterization results.

2. Characterization is done according to JEDEC JESD22-A117.

6.3.10 EMC characteristics

Susceptibility tests are performed on a sample basis during device characterization.

Functional EMS (electromagnetic susceptibility)

While a simple application is executed on the device (toggling 2 LEDs through I/O ports), the device is stressed by two electromagnetic events until a failure occurs. The failure is indicated by the LEDs:

- **Electrostatic discharge (ESD)** (positive and negative) is applied to all device pins until a functional disturbance occurs. This test is compliant with the IEC 61000-4-2 standard.
- **FTB: A Burst of Fast Transient voltage** (positive and negative) is applied to V_{DD} and V_{SS} through a 100 pF capacitor, until a functional disturbance occurs. This test is compliant with the IEC 61000-4-4 standard.

A device reset allows normal operations to be resumed.

The test results are given in [Table 36](#). They are based on the EMS levels and classes defined in application note AN1709.

Table 36. EMS characteristics

| Symbol | Parameter | Conditions | Level/Class |
|------------|---|--|-------------|
| V_{FESD} | Voltage limits to be applied on any I/O pin to induce a functional disturbance | $V_{DD} = 3.3\text{ V}$, $T_A = +25\text{ }^\circ\text{C}$, $f_{HCLK} = 32\text{ MHz}$ conforms to IEC 61000-4-2 | 2B |
| V_{EFTB} | Fast transient voltage burst limits to be applied through 100 pF on V_{DD} and V_{SS} pins to induce a functional disturbance | $V_{DD} = 3.3\text{ V}$, $T_A = +25\text{ }^\circ\text{C}$, $f_{HCLK} = 32\text{ MHz}$ conforms to IEC 61000-4-4 | 4A |

Designing hardened software to avoid noise problems

EMC characterization and optimization are performed at component level with a typical application environment and simplified MCU software. It should be noted that good EMC performance is highly dependent on the user application and the software in particular.

Therefore it is recommended that the user applies EMC software optimization and prequalification tests in relation with the EMC level requested for his application.

Software recommendations

The software flowchart must include the management of runaway conditions such as:

- Corrupted program counter
- Unexpected reset
- Critical data corruption (control registers...)

Prequalification trials

Most of the common failures (unexpected reset and program counter corruption) can be reproduced by manually forcing a low state on the NRST pin or the oscillator pins for 1 second.

To complete these trials, ESD stress can be applied directly on the device, over the range of specification values. When unexpected behavior is detected, the software can be hardened to prevent unrecoverable errors occurring (see application note AN1015).

Electromagnetic Interference (EMI)

The electromagnetic field emitted by the device are monitored while a simple application is executed (toggling 2 LEDs through the I/O ports). This emission test is compliant with IEC 61967-2 standard which specifies the test board and the pin loading.

Table 37. EMI characteristics

| Symbol | Parameter | Conditions | Monitored frequency band | Max vs. frequency range | | | Unit |
|------------------|------------|---|--------------------------|-------------------------|------------------------|------------------------|------|
| | | | | 4 MHz voltage range 3 | 16 MHz voltage range 2 | 32 MHz voltage range 1 | |
| S _{EMI} | Peak level | V _{DD} = V, T _A = 25 °C, package compliant with IEC 61967-2 | 0.1 to 30 MHz | 3 | -6 | -5 | dBµV |
| | | | 30 to 130 MHz | 18 | 4 | -7 | |
| | | | 130 MHz to 1GHz | 15 | 5 | -7 | |
| | | | SAE EMI Level | 2.5 | 2 | 1 | - |

6.3.11 Electrical sensitivity characteristics

Based on three different tests (ESD, LU) using specific measurement methods, the device is stressed in order to determine its performance in terms of electrical sensitivity.

Electrostatic discharge (ESD)

Electrostatic discharges (a positive then a negative pulse separated by 1 second) are applied to the pins of each sample according to each pin combination. The sample size depends on the number of supply pins in the device (3 parts × (n+1) supply pins). This test conforms to the JESD22-A114, ANSI/ESD STM5.3.1. standard.

Table 38. ESD absolute maximum ratings

| Symbol | Ratings | Conditions | Class | Maximum value ⁽¹⁾ | Unit |
|-----------------------|---|---|-------|------------------------------|------|
| V _{ESD(HBM)} | Electrostatic discharge voltage (human body model) | T _A = +25 °C, conforming to JESD22-A114 | 2 | 2000 | V |
| V _{ESD(CDM)} | Electrostatic discharge voltage (charge device model) | T _A = +25 °C, conforming to ANSI/ESD STM5.3.1. | C4 | 500 | V |

1. Guaranteed by characterization results.



Static latch-up

Two complementary static tests are required on six parts to assess the latch-up performance:

- A supply overvoltage is applied to each power supply pin
- A current injection is applied to each input, output and configurable I/O pin

These tests are compliant with EIA/JESD 78A IC latch-up standard.

Table 39. Electrical sensitivities

| Symbol | Parameter | Conditions | Class |
|--------|-----------------------|--|------------|
| LU | Static latch-up class | T _A = +105 °C conforming to JESD78A | II level A |

6.3.12 I/O current injection characteristics

As a general rule, current injection to the I/O pins, due to external voltage below V_{SS} or above V_{DD} (for standard pins) should be avoided during normal product operation. However, in order to give an indication of the robustness of the microcontroller in cases when abnormal injection accidentally happens, susceptibility tests are performed on a sample basis during device characterization.

Functional susceptibility to I/O current injection

While a simple application is executed on the device, the device is stressed by injecting current into the I/O pins programmed in floating input mode. While current is injected into the I/O pin, one at a time, the device is checked for functional failures.

The failure is indicated by an out of range parameter: ADC error above a certain limit (higher than 5 LSB TUE), out of conventional limits of induced leakage current on adjacent pins (out of -5 µA/+0 µA range), or other functional failure (for example reset occurrence oscillator frequency deviation, LCD levels).

The test results are given in the [Table 40](#).

Table 40. I/O current injection susceptibility

| Symbol | Description | Functional susceptibility | | Unit |
|------------------|--|---------------------------|--------------------|------|
| | | Negative injection | Positive injection | |
| I _{INJ} | Injected current on all 5 V tolerant (FT) pins | -5 ⁽¹⁾ | NA ⁽²⁾ | mA |
| | Injected current on BOOT0 | -0 | NA ⁽²⁾ | |
| | Injected current on any other pin | -5 ⁽¹⁾ | +5 | |

1. It is recommended to add a Schottky diode (pin to ground) to analog pins which may potentially inject negative currents.
2. Injection is not possible.

6.3.13 I/O port characteristics

General input/output characteristics

Unless otherwise specified, the parameters given in [Table 47](#) are derived from tests performed under the conditions summarized in [Table 12](#). All I/Os are CMOS and TTL compliant.

Table 41. I/O static characteristics

| Symbol | Parameter | Conditions | Min | Typ | Max | Unit |
|------------------|---|--|---|------------------------------------|---------------------------------------|------|
| V _{IL} | Input low level voltage | TC and FT I/O | - | - | 0.3 V _{DD} ⁽¹⁾⁽²⁾ | V |
| | | BOOT0 | - | - | 0.14 V _{DD} ⁽²⁾ | |
| V _{IH} | Input high level voltage | TC I/O | 0.45 V _{DD} +0.38 ⁽²⁾ | - | - | |
| | | FT I/O | 0.39 V _{DD} +0.59 ⁽²⁾ | - | - | |
| | | BOOT0 | 0.15 V _{DD} +0.56 ⁽²⁾ | - | - | |
| V _{hys} | I/O Schmitt trigger voltage hysteresis ⁽²⁾ | TC and FT I/O | - | 10% V _{DD} ⁽³⁾ | - | |
| | | BOOT0 | - | 0.01 | - | |
| I _{lkg} | Input leakage current ⁽⁴⁾ | V _{SS} ≤ V _{IN} ≤ V _{DD} I/Os with LCD | - | - | ±50 | nA |
| | | V _{SS} ≤ V _{IN} ≤ V _{DD} I/Os with analog switches | - | - | ±50 | |
| | | V _{SS} ≤ V _{IN} ≤ V _{DD} I/Os with analog switches and LCD | - | - | ±50 | |
| | | V _{SS} ≤ V _{IN} ≤ V _{DD} I/Os with USB | - | - | ±250 | |
| | | V _{SS} ≤ V _{IN} ≤ V _{DD} TC and FT I/Os | - | - | ±50 | |
| | | FT I/O V _{DD} ≤ V _{IN} ≤ 5V | - | - | ±10 | μA |
| R _{PU} | Weak pull-up equivalent resistor ⁽⁵⁾⁽¹⁾ | V _{IN} = V _{SS} | 25 | 45 | 65 | kΩ |
| R _{PD} | Weak pull-down equivalent resistor ⁽⁵⁾ | V _{IN} = V _{DD} | 25 | 45 | 65 | kΩ |
| C _{IO} | I/O pin capacitance | - | - | 5 | - | pF |

1. Guaranteed by test in production.
2. Guaranteed by design.
3. With a minimum of 200 mV.
4. The max. value may be exceeded if negative current is injected on adjacent pins.
5. Pull-up and pull-down resistors are designed with a true resistance in series with a switchable PMOS/NMOS. This MOS/NMOS contribution to the series resistance is minimum (~10% order).

Output driving current

The GPIOs (general purpose input/outputs) can sink or source up to ± 8 mA, and sink or source up to ± 20 mA with the non-standard V_{OL}/V_{OH} specifications given in [Table 42](#).

In the user application, the number of I/O pins which can drive current must be limited to respect the absolute maximum rating specified in [Section 6.2](#):

- The sum of the currents sourced by all the I/Os on V_{DD} , plus the maximum Run consumption of the MCU sourced on V_{DD} , cannot exceed the absolute maximum rating $I_{VDD(\Sigma)}$ (see [Table 10](#)).
- The sum of the currents sunk by all the I/Os on V_{SS} plus the maximum Run consumption of the MCU sunk on V_{SS} cannot exceed the absolute maximum rating $I_{VSS(\Sigma)}$ (see [Table 10](#)).

Output voltage levels

Unless otherwise specified, the parameters given in [Table 42](#) are derived from tests performed under the conditions summarized in [Table 12](#). All I/Os are CMOS and TTL compliant.

Table 42. Output voltage characteristics

| Symbol | Parameter | Conditions | Min | Max | Unit |
|-------------------|--|--|---------------|------|------|
| $V_{OL}^{(1)(2)}$ | Output low level voltage for an I/O pin | $I_{IO} = 8$ mA 2.7 V < V_{DD} < 3.6 V | - | 0.4 | V |
| $V_{OH}^{(2)(3)}$ | Output high level voltage for an I/O pin | | $V_{DD}-0.4$ | - | |
| $V_{OL}^{(3)(4)}$ | Output low level voltage for an I/O pin | $I_{IO} = 4$ mA 1.65 V < V_{DD} < 3.6 V | - | 0.45 | |
| $V_{OH}^{(3)(4)}$ | Output high level voltage for an I/O pin | | $V_{DD}-0.45$ | - | |
| $V_{OL}^{(1)(4)}$ | Output low level voltage for an I/O pin | $I_{IO} = 20$ mA 2.7 V < V_{DD} < 3.6 V | - | 1.3 | |
| $V_{OH}^{(3)(4)}$ | Output high level voltage for an I/O pin | | $V_{DD}-1.3$ | - | |

1. The I_{IO} current sunk by the device must always respect the absolute maximum rating specified in [Table 10](#) and the sum of I_{IO} (I/O ports and control pins) must not exceed I_{VSS} .
2. Guaranteed by test in production.
3. The I_{IO} current sourced by the device must always respect the absolute maximum rating specified in [Table 10](#) and the sum of I_{IO} (I/O ports and control pins) must not exceed I_{VDD} .
4. Guaranteed by characterization results.

Input/output AC characteristics

The definition and values of input/output AC characteristics are given in [Figure 14](#) and [Table 43](#), respectively.

Unless otherwise specified, the parameters given in [Table 43](#) are derived from tests performed under the conditions summarized in [Table 12](#).

Table 43. I/O AC characteristics⁽¹⁾

| OSPEEDRx [1:0] bit value ⁽¹⁾ | Symbol | Parameter | Conditions | Min | Max ⁽²⁾ | Unit |
|---|--|---|---|-----|--------------------|------|
| 00 | f _{max(IO)out} | Maximum frequency ⁽³⁾ | C _L = 50 pF, V _{DD} = 2.7 V to 3.6 V | - | 400 | kHz |
| | | | C _L = 50 pF, V _{DD} = 1.65 V to 2.7 V | - | 400 | |
| | t _{f(IO)out} t _{r(IO)out} | Output rise and fall time | C _L = 50 pF, V _{DD} = 2.7 V to 3.6 V | - | 625 | ns |
| | | | C _L = 50 pF, V _{DD} = 1.65 V to 2.7 V | - | 625 | |
| 01 | f _{max(IO)out} | Maximum frequency ⁽³⁾ | C _L = 50 pF, V _{DD} = 2.7 V to 3.6 V | - | 2 | MHz |
| | | | C _L = 50 pF, V _{DD} = 1.65 V to 2.7 V | - | 1 | |
| | t _{f(IO)out} t _{r(IO)out} | Output rise and fall time | C _L = 50 pF, V _{DD} = 2.7 V to 3.6 V | - | 125 | ns |
| | | | C _L = 50 pF, V _{DD} = 1.65 V to 2.7 V | - | 250 | |
| 10 | F _{max(IO)out} | Maximum frequency ⁽³⁾ | C _L = 50 pF, V _{DD} = 2.7 V to 3.6 V | - | 10 | MHz |
| | | | C _L = 50 pF, V _{DD} = 1.65 V to 2.7 V | - | 2 | |
| | t _{f(IO)out} t _{r(IO)out} | Output rise and fall time | C _L = 50 pF, V _{DD} = 2.7 V to 3.6 V | - | 25 | ns |
| | | | C _L = 50 pF, V _{DD} = 1.65 V to 2.7 V | - | 125 | |
| 11 | F _{max(IO)out} | Maximum frequency ⁽³⁾ | C _L = 30 pF, V _{DD} = 2.7 V to 3.6 V | - | 50 | MHz |
| | | | C _L = 50 pF, V _{DD} = 1.65 V to 2.7 V | - | 8 | |
| | t _{f(IO)out} t _{r(IO)out} | Output rise and fall time | C _L = 30 pF, V _{DD} = 2.7 V to 3.6 V | - | 5 | ns |
| | | | C _L = 50 pF, V _{DD} = 1.65 V to 2.7 V | - | 30 | |
| - | t _{EXTIpw} | Pulse width of external signals detected by the EXTI controller | - | 8 | - | ns |

1. The I/O speed is configured using the OSPEEDRx[1:0] bits. Refer to the STM32L151xx, STM32L152xx and STM32L162xx reference manual for a description of GPIO Port configuration register.
2. Guaranteed by design.
3. The maximum frequency is defined in [Figure 14](#).



Figure 14. I/O AC characteristics definition

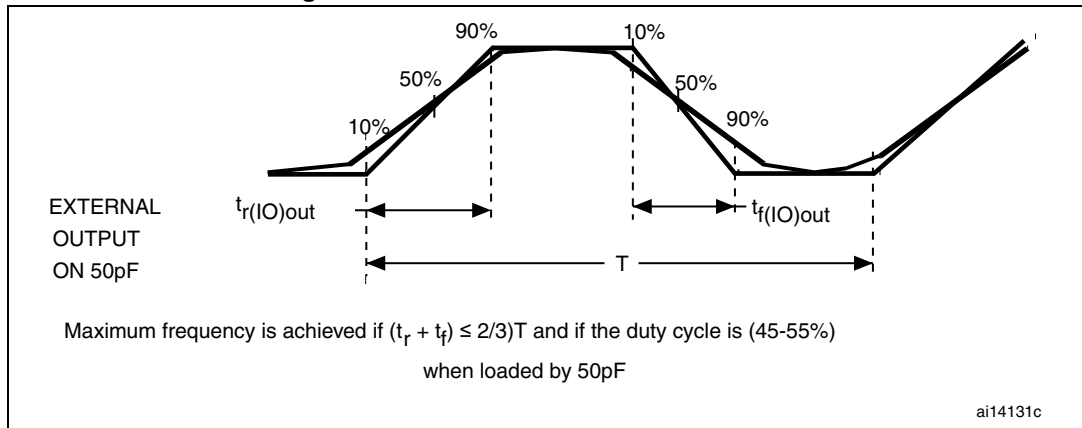

6.3.14 NRST pin characteristics

The NRST pin input driver uses CMOS technology. It is connected to a permanent pull-up resistor, R_{PU} (see [Table 44](#))

Unless otherwise specified, the parameters given in [Table 44](#) are derived from tests performed under the conditions summarized in [Table 12](#).

Table 44. NRST pin characteristics

| Symbol | Parameter | Conditions | Min | Typ | Max | Unit |
|-----------------------|---|--|-------------------|--------------------|--------------|------------|
| $V_{IL(NRST)}^{(1)}$ | NRST input low level voltage | - | - | - | $0.3 V_{DD}$ | V |
| $V_{IH(NRST)}^{(1)}$ | NRST input high level voltage | - | $0.39V_{DD}+0.59$ | - | - | |
| $V_{OL(NRST)}^{(1)}$ | NRST output low level voltage | $I_{OL} = 2 \text{ mA}$ $2.7 \text{ V} < V_{DD} < 3.6 \text{ V}$ | - | - | 0.4 | |
| | | $I_{OL} = 1.5 \text{ mA}$ $1.65 \text{ V} < V_{DD} < 2.7 \text{ V}$ | - | - | | |
| $V_{hys(NRST)}^{(1)}$ | NRST Schmitt trigger voltage hysteresis | - | - | $10\%V_{DD}^{(2)}$ | - | mV |
| R_{PU} | Weak pull-up equivalent resistor ⁽³⁾ | $V_{IN} = V_{SS}$ | 25 | 45 | 65 | k Ω |
| $V_{F(NRST)}^{(1)}$ | NRST input filtered pulse | - | - | - | 50 | ns |
| $V_{NF(NRST)}^{(3)}$ | NRST input not filtered pulse | - | 350 | - | - | ns |

1. Guaranteed by design.
2. With a minimum of 200 mV.
3. The pull-up is designed with a true resistance in series with a switchable PMOS. This PMOS contribution to the series resistance is around 10%.

Figure 15. Recommended NRST pin protection

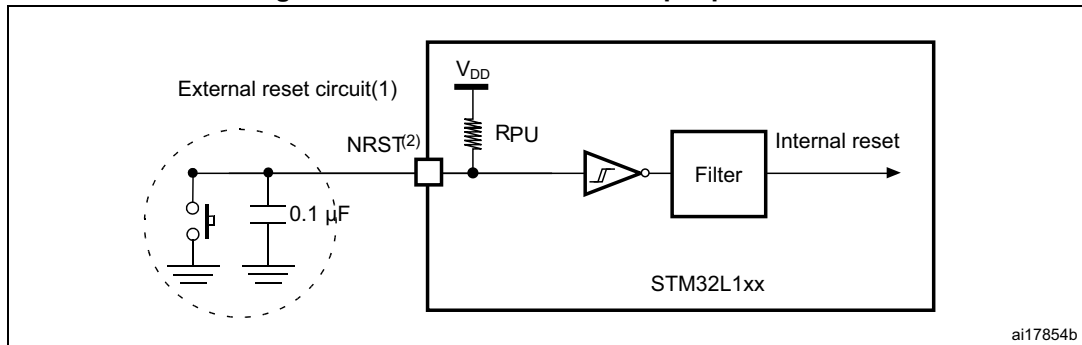

1. The reset network protects the device against parasitic resets. 0.1 uF capacitor must be placed as close as possible to the chip.
2. The user must ensure that the level on the NRST pin can go below the $V_{IL(NRST)}$ max level specified in [Table 44](#). Otherwise the reset will not be taken into account by the device.

6.3.15 TIM timer characteristics

The parameters given in the [Table 45](#) are guaranteed by design.

Refer to [Section 6.3.13: I/O port characteristics](#) for details on the input/output ction characteristics (output compare, input capture, external clock, PWM output).

Table 45. TIMx⁽¹⁾ characteristics

| Symbol | Parameter | Conditions | Min | Max | Unit |
|------------------|--|--------------------------------|--------|----------------------|---------------|
| $t_{res(TIM)}$ | Timer resolution time | - | 1 | - | $t_{TIMxCLK}$ |
| | | $f_{TIMxCLK} = 32 \text{ MHz}$ | 31.25 | - | ns |
| f_{EXT} | Timer external clock frequency on CH1 to CH4 | - | 0 | $f_{TIMxCLK}/2$ | MHz |
| | | $f_{TIMxCLK} = 32 \text{ MHz}$ | 0 | 16 | MHz |
| Res_{TIM} | Timer resolution | - | - | 16 | bit |
| $t_{COUNTER}$ | 16-bit counter clock period when internal clock is selected (timer's prescaler disabled) | - | 1 | 65536 | $t_{TIMxCLK}$ |
| | | $f_{TIMxCLK} = 32 \text{ MHz}$ | 0.0312 | 2048 | μs |
| t_{MAX_COUNT} | Maximum possible count | - | - | 65536×65536 | $t_{TIMxCLK}$ |
| | | $f_{TIMxCLK} = 32 \text{ MHz}$ | - | 134.2 | s |

1. TIMx is used as a general term to refer to the TIM2, TIM3 and TIM4 timers.

6.3.16 Communications interfaces

I²C interface characteristics

The device I²C interface meets the requirements of the standard I²C communication protocol with the following restrictions: SDA and SCL are not “true” open-drain I/O pins. When configured as open-drain, the PMOS connected between the I/O pin and V_{DD} is disabled, but is still present.

The I²C characteristics are described in [Table 46](#). Refer also to [Section 6.3.13: I/O port characteristics](#) for more details on the input/output ction characteristics (SDA and SCL).

Table 46. I²C characteristics

| Symbol | Parameter | Standard mode I ² C ⁽¹⁾⁽²⁾ | | Fast mode I ² C ⁽¹⁾⁽²⁾ | | Unit |
|--|--|--|---------------------|--|--------------------|------|
| | | Min | Max | Min | Max | |
| t _{w(SCLL)} | SCL clock low time | 4.7 | - | 1.3 | - | μs |
| t _{w(SCLH)} | SCL clock high time | 4.0 | - | 0.6 | - | |
| t _{su(SDA)} | SDA setup time | 250 | - | 100 | - | ns |
| t _{h(SDA)} | SDA data hold time | - | 3450 ⁽³⁾ | - | 900 ⁽³⁾ | |
| t _{r(SDA)} t _{r(SCL)} | SDA and SCL rise time | - | 1000 | - | 300 | |
| t _{f(SDA)} t _{f(SCL)} | SDA and SCL fall time | - | 300 | - | 300 | |
| t _{h(STA)} | Start condition hold time | 4.0 | - | 0.6 | - | μs |
| t _{su(STA)} | Repeated Start condition setup time | 4.7 | - | 0.6 | - | |
| t _{su(STO)} | Stop condition setup time | 4.0 | - | 0.6 | - | μs |
| t _{w(STO:STA)} | Stop to Start condition time (bus free) | 4.7 | - | 1.3 | - | μs |
| C _b | Capacitive load for each bus line | - | 400 | - | 400 | pF |
| t _{SP} | Pulse width of spikes that are suppressed by the analog filter | 0 | 50 ⁽⁴⁾ | 0 | 50 ⁽⁴⁾ | ns |

1. Guaranteed by design.
2. f_{PCLK1} must be at least 2 MHz to achieve standard mode I²C frequencies. It must be at least 4 MHz to achieve fast mode I²C frequencies. It must be a multiple of 10 MHz to reach the 400 kHz maximum I²C fast mode clock.
3. The maximum Data hold time has only to be met if the interface does not stretch the low period of SCL signal.
4. The minimum width of the spikes filtered by the analog filter is above t_{SP(max)}.

Figure 16. I²C bus AC waveforms and measurement circuit

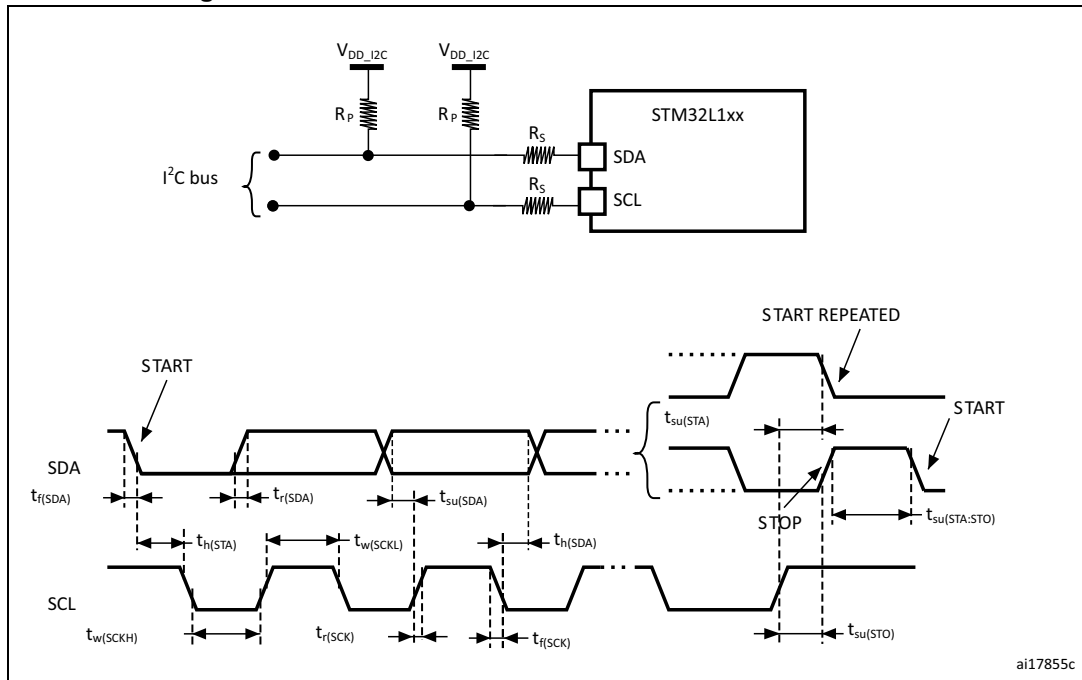

1. R_S = series protection resistor.
2. R_P = external pull-up resistor.
3. V_{DD_I2C} is the I2C bus power supply.
4. Measurement points are done at CMOS levels: $0.3V_{DD}$ and $0.7V_{DD}$.

Table 47. SCL frequency ($f_{PCLK1} = 32\text{ MHz}$, $V_{DD} = V_{DD_I2C} = 3.3\text{ V}$)⁽¹⁾⁽²⁾

| f_{SCL} (kHz) | I2C_CCR value |
|-----------------|----------------------------|
| | $R_P = 4.7\text{ k}\Omega$ |
| 400 | 0x801B |
| 300 | 0x8024 |
| 200 | 0x8035 |
| 100 | 0x00A0 |
| 50 | 0x0140 |
| 20 | 0x0320 |

1. R_P = External pull-up resistance, $f_{SCL} = I^2C$ speed.
2. For speeds around 200 kHz, the tolerance on the achieved speed is of $\pm 5\%$. For other speed ranges, the tolerance on the achieved speed is $\pm 2\%$. These variations depend on the accuracy of the external components used to design the application.

SPI characteristics

Unless otherwise specified, the parameters given in the following table are derived from tests performed under the conditions summarized in [Table 12](#).

Refer to [Section 6.3.12: I/O current injection characteristics](#) for more details on the input/output alternate function characteristics (NSS, SCK, MOSI, MISO).

Table 48. SPI characteristics⁽¹⁾

| Symbol | Parameter | Conditions | Min | Max ⁽²⁾ | Unit |
|--|----------------------------------|----------------------------|-------------------------|-------------------------|------|
| f _{SCK} 1/t _{c(SCK)} | SPI clock frequency | Master mode | - | 16 | MHz |
| | | Slave mode | - | 16 | |
| | | Slave transmitter | - | 12 ⁽³⁾ | |
| t _{r(SCK)} ⁽²⁾ t _{f(SCK)} ⁽²⁾ | SPI clock rise and fall time | Capacitive load: C = 30 pF | - | 6 | ns |
| DuCy(SCK) | SPI slave input clock duty cycle | Slave mode | 30 | 70 | % |
| t _{su(NSS)} | NSS setup time | Slave mode | 4t _{HCLK} | - | ns |
| t _{h(NSS)} | NSS hold time | Slave mode | 2t _{HCLK} | - | |
| t _{w(SCKH)} ⁽²⁾ t _{w(SCKL)} ⁽²⁾ | SCK high and low time | Master mode | t _{SCK} /2 - 5 | t _{SCK} /2 + 3 | |
| t _{su(MI)} ⁽²⁾ | Data input setup time | Master mode | 5 | - | |
| t _{su(SI)} ⁽²⁾ | | Slave mode | 6 | - | |
| t _{h(MI)} ⁽²⁾ | Data input hold time | Master mode | 5 | - | |
| t _{h(SI)} ⁽²⁾ | | Slave mode | 5 | - | |
| t _{a(SO)} ⁽⁴⁾ | Data output access time | Slave mode | 0 | 3t _{HCLK} | |
| t _{v(SO)} ⁽²⁾ | Data output valid time | Slave mode | - | 33 | |
| t _{v(MO)} ⁽²⁾ | Data output valid time | Master mode | - | 6.5 | |
| t _{h(SO)} ⁽²⁾ | Data output hold time | Slave mode | 17 | - | |
| t _{h(MO)} ⁽²⁾ | | Master mode | 0.5 | - | |

1. The characteristics above are given for voltage range 1.
2. Guaranteed by characterization results.
3. The maximum SPI clock frequency in slave transmitter mode is given for an SPI slave input clock duty cycle (DuCy(SCK)) ranging between 40 to 60%.
4. Min time is for the minimum time to drive the output and max time is for the maximum time to validate the data.

Figure 17. SPI timing diagram - slave mode and CPHA = 0

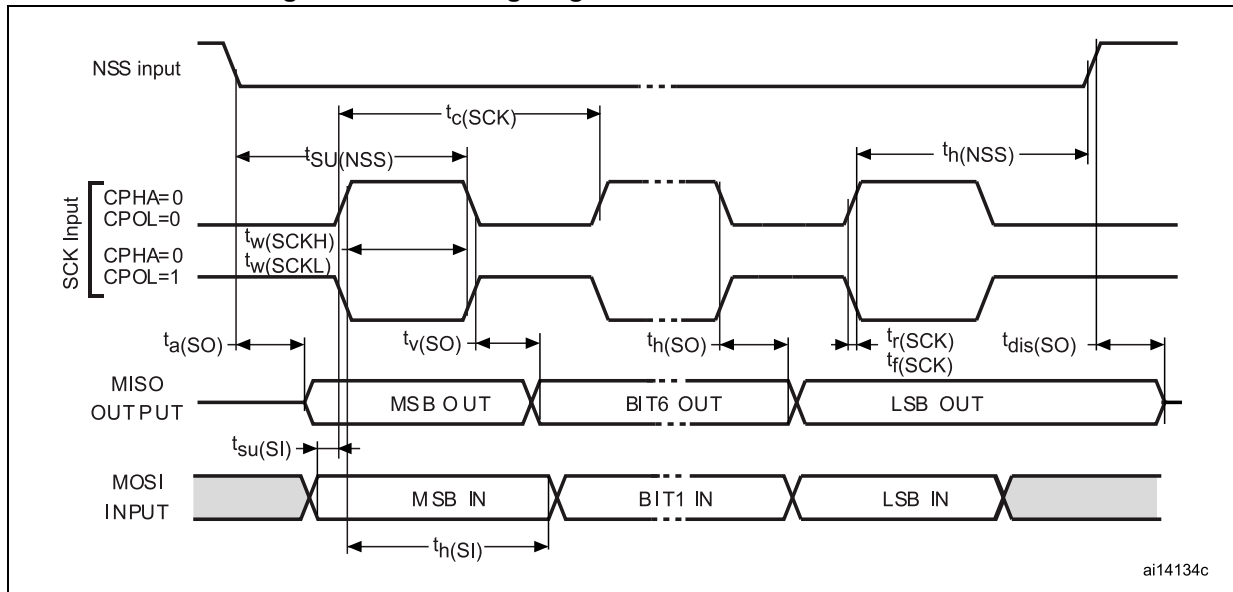
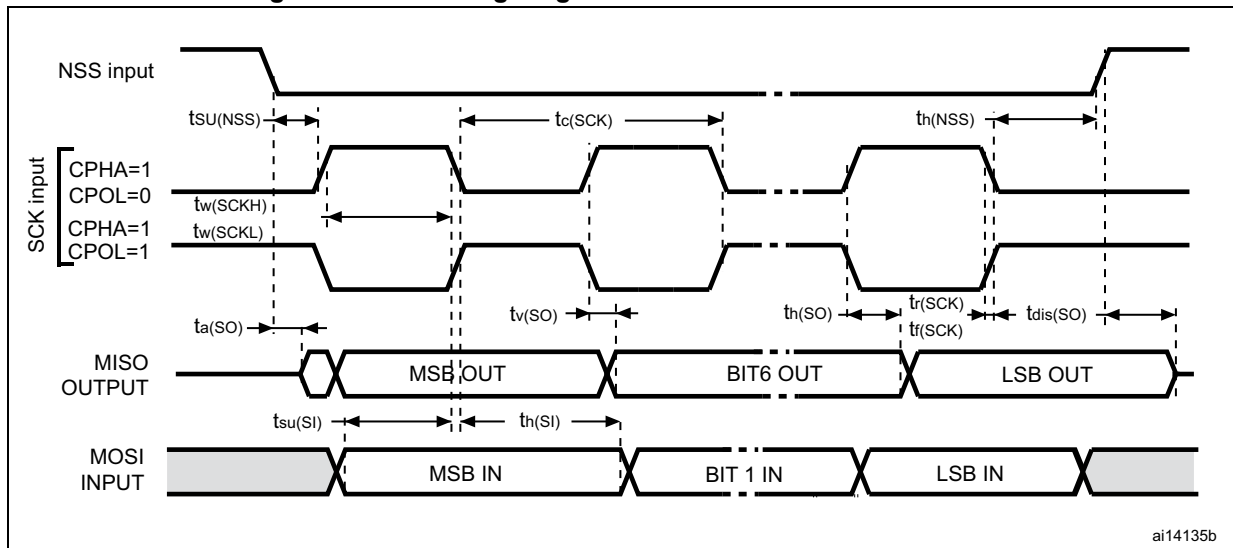
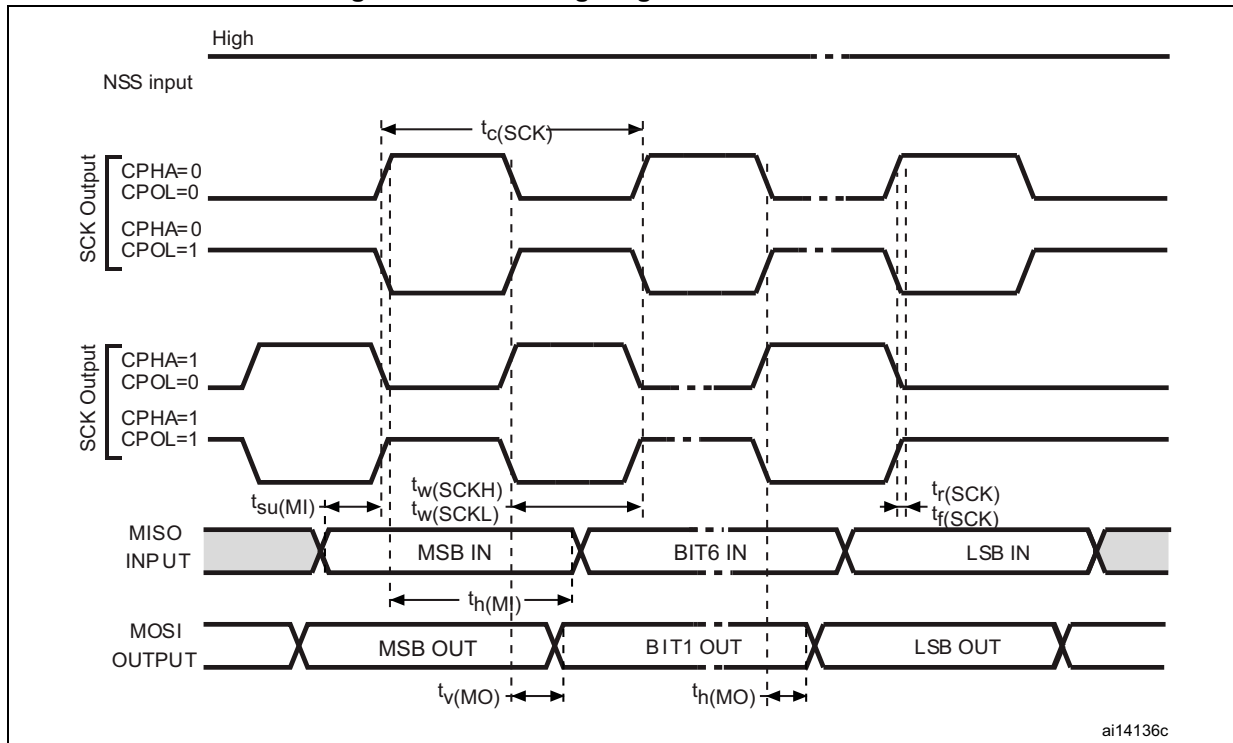

Figure 18. SPI timing diagram - slave mode and CPHA = 1⁽¹⁾



1. Measurement points are done at CMOS levels: 0.3V_{DD} and 0.7V_{DD}.

Figure 19. SPI timing diagram - master mode⁽¹⁾



1. Measurement points are done at CMOS levels: $0.3V_{DD}$ and $0.7V_{DD}$.

USB characteristics

The USB interface is USB-IF certified (full speed).

Table 49. USB startup time

| Symbol | Parameter | Max | Unit |
|---------------------|------------------------------|-----|---------|
| $t_{STARTUP}^{(1)}$ | USB transceiver startup time | 1 | μs |

1. Guaranteed by design.

Table 50. USB DC electrical characteristics

| Symbol | Parameter | Conditions | Min. ⁽¹⁾ | Max. ⁽¹⁾ | Unit |
|----------------------|---------------------------------|---|---------------------|---------------------|------|
| Input levels | | | | | |
| V_{DD} | USB operating voltage | - | 3.0 | 3.6 | V |
| $V_{DI}^{(2)}$ | Differential input sensitivity | I(USB_DP, USB_DM) | 0.2 | - | V |
| $V_{CM}^{(2)}$ | Differential common mode range | Includes V_{DI} range | 0.8 | 2.5 | |
| $V_{SE}^{(2)}$ | Single ended receiver threshold | - | 1.3 | 2.0 | |
| Output levels | | | | | |
| $V_{OL}^{(3)}$ | Static output level low | R_L of 1.5 k Ω to 3.6 V ⁽⁴⁾ | - | 0.3 | V |
| $V_{OH}^{(3)}$ | Static output level high | R_L of 15 k Ω to $V_{SS}^{(4)}$ | 2.8 | 3.6 | |

1. All the voltages are measured from the local ground potential.
2. Guaranteed by characterization results.
3. Guaranteed by test in production.
4. R_L is the load connected on the USB drivers.

Figure 20. USB timings: definition of data signal rise and fall time

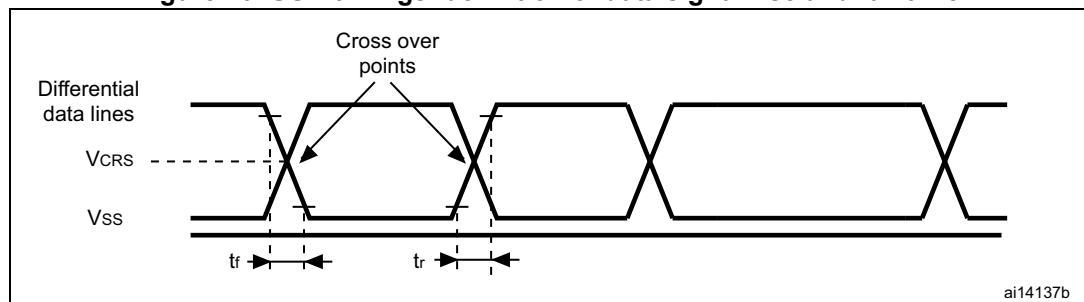

Table 51. USB: full speed electrical characteristics

| Driver characteristics ⁽¹⁾ | | | | | |
|---------------------------------------|---------------------------------|---------------|-----|-----|------|
| Symbol | Parameter | Conditions | Min | Max | Unit |
| t_r | Rise time ⁽²⁾ | $C_L = 50$ pF | 4 | 20 | ns |
| t_f | Fall Time ⁽²⁾ | $C_L = 50$ pF | 4 | 20 | ns |
| t_{rfm} | Rise/ fall time matching | t_r/t_f | 90 | 110 | % |
| V_{CRS} | Output signal crossover voltage | | 1.3 | 2.0 | V |

1. Guaranteed by design.
2. Measured from 10% to 90% of the data signal. For more detailed informations, please refer to USB Specification - Chapter 7 (version 2.0).

I2S characteristics

Table 52. I2S characteristics

| Symbol | Parameter | Conditions | Min | Max | Unit |
|------------------------|--------------------------------|--|----------|-----------------------|------|
| f _{MCK} | I2S Main Clock Output | | 256 x 8K | 256xFs ⁽¹⁾ | MHz |
| f _{CK} | I2S clock frequency | Master data: 32 bits | - | 64xFs | MHz |
| | | Slave data: 32 bits | - | 64xFs | |
| D _{CK} | I2S clock frequency duty cycle | Slave receiver, 48KHz | 30 | 70 | % |
| t _{r(CK)} | I2S clock rise time | Capacitive load CL=30pF | - | 8 | ns |
| t _{f(CK)} | I2S clock fall time | | | 8 | |
| t _{v(WS)} | WS valid time | Master mode | 4 | 24 | |
| t _{h(WS)} | WS hold time | Master mode | 0 | - | |
| t _{su(WS)} | WS setup time | Slave mode | 15 | - | |
| t _{h(WS)} | WS hold time | Slave mode | 0 | - | |
| t _{su(SD_MR)} | Data input setup time | Master receiver | 8 | - | |
| t _{su(SD_SR)} | Data input setup time | Slave receiver | 9 | - | |
| t _{h(SD_MR)} | Data input hold time | Master receiver | 5 | - | |
| t _{h(SD_SR)} | | Slave receiver | 4 | - | |
| t _{v(SD_ST)} | Data output valid time | Slave transmitter (after enable edge) | - | 64 | |
| t _{h(SD_ST)} | Data output hold time | Slave transmitter (after enable edge) | 22 | - | |
| t _{v(SD_MT)} | Data output valid time | Master transmitter (after enable edge) | - | 12 | |
| t _{h(SD_MT)} | Data output hold time | Master transmitter (after enable edge) | 8 | - | |

1. The maximum for 256xFs is 8 MHz

Note: Refer to the I2S section of the product reference manual for more details about the sampling frequency (Fs), f_{MCK}, f_{CK} and D_{CK} values. These values reflect only the digital peripheral behavior, source clock precision might slightly change them. D_{CK} depends mainly on the ODD bit value, digital contribution leads to a min of (I2SDIV/(2*I2SDIV+ODD)) and a max of (I2SDIV+ODD)/(2*I2SDIV+ODD). Fs max is supported for each mode/condition.

Figure 21. I²S slave timing diagram (Philips protocol)⁽¹⁾

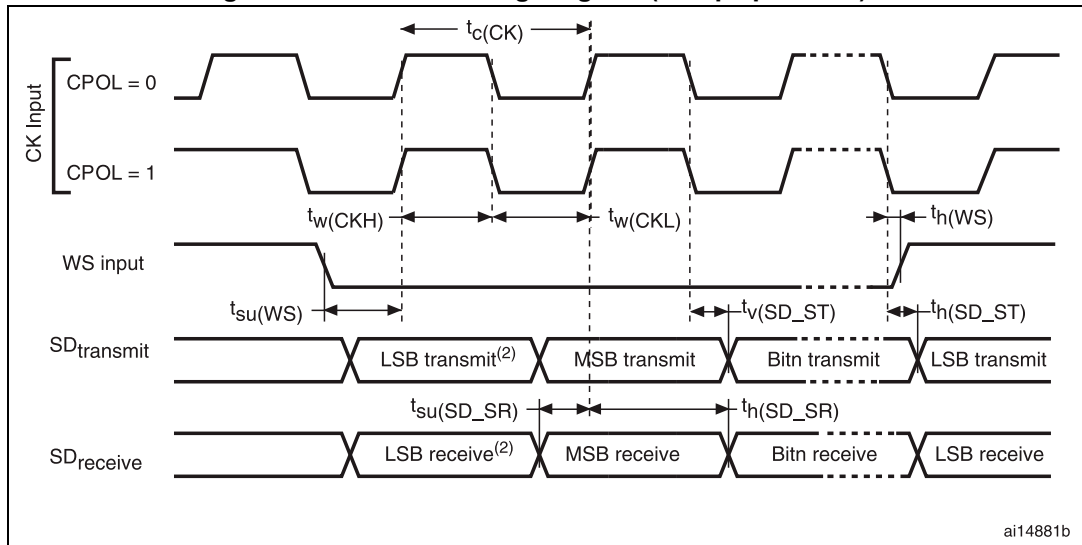

1. Measurement points are done at CMOS levels: $0.3 \times V_{DD}$ and $0.7 \times V_{DD}$.
2. LSB transmit/receive of the previously transmitted byte. No LSB transmit/receive is sent before the first byte.

Figure 22. I²S master timing diagram (Philips protocol)⁽¹⁾

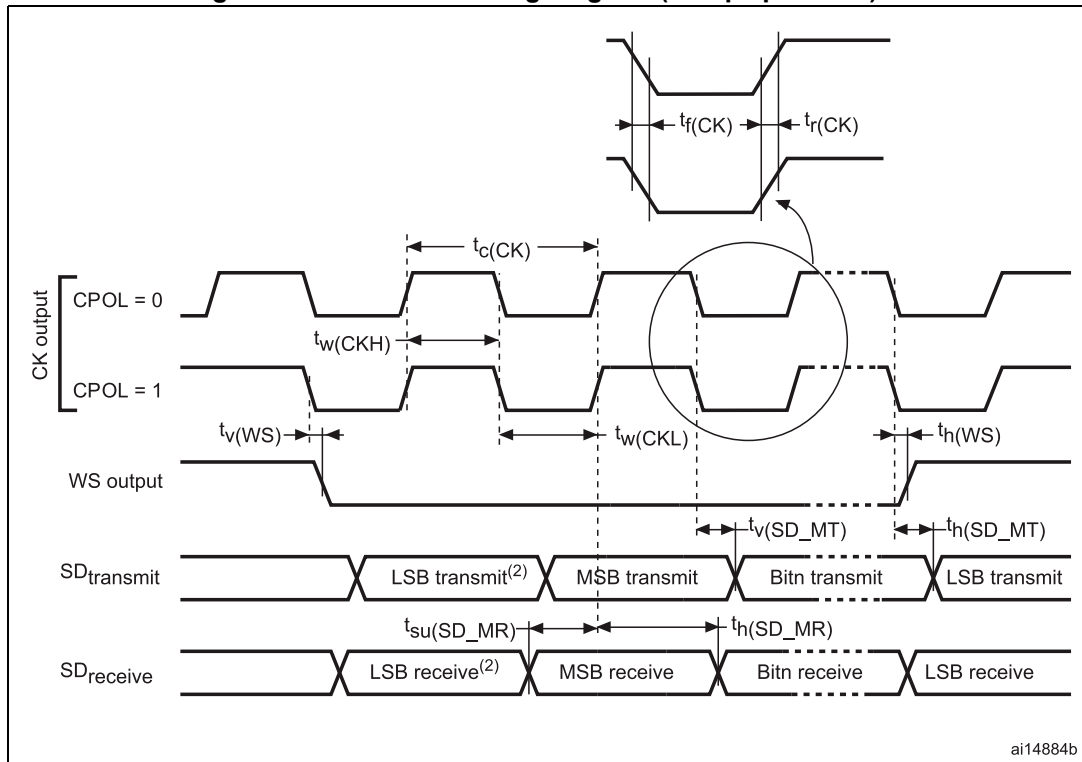

1. Guaranteed by characterization results.
2. LSB transmit/receive of the previously transmitted byte. No LSB transmit/receive is sent before the first byte.

6.3.17 12-bit ADC characteristics

Unless otherwise specified, the parameters given in Table 54 are guaranteed by design.

Table 53. ADC clock frequency

| Symbol | Parameter | Conditions | | Min | Max | Unit |
|------------------|---------------------|---------------------|----------------------------------|---|-----|------|
| f _{ADC} | ADC clock frequency | Voltage range 1 & 2 | 2.4 V ≤ V _{DDA} ≤ 3.6 V | V _{REF+} = V _{DDA} | 16 | MHz |
| | | | | V _{REF+} < V _{DDA} V _{REF+} > 2.4 V | 8 | |
| | | | | V _{REF+} < V _{DDA} V _{REF+} ≤ 2.4 V | 4 | |
| | | Voltage range 3 | 1.8 V ≤ V _{DDA} ≤ 2.4 V | V _{REF+} = V _{DDA} | 8 | |
| | | | | V _{REF+} < V _{DDA} | 4 | |
| | | | | | 4 | |

Table 54. ADC characteristics

| Symbol | Parameter | Conditions | Min | Typ | Max | Unit |
|----------------------------------|---|----------------------|--------------------|------------------|-------------------|------|
| V _{DDA} | Power supply | - | 1.8 | - | 3.6 | V |
| V _{REF+} | Positive reference voltage | - | 1.8 ⁽¹⁾ | - | V _{DDA} | |
| V _{REF-} | Negative reference voltage | - | - | V _{SSA} | - | |
| I _{VDDA} | Current on the V _{DDA} input pin | - | - | 1000 | 1450 | μA |
| I _{VREF} ⁽²⁾ | Current on the V _{REF} input pin | Peak | - | 400 | 700 | |
| | | Average | | | 450 | |
| V _{AIN} | Conversion voltage range ⁽³⁾ | - | 0 ⁽⁴⁾ | - | V _{REF+} | V |
| f _s | 12-bit sampling rate | Direct channels | - | - | 1 | MSPS |
| | | Multiplexed channels | - | - | 0.76 | |
| | 10-bit sampling rate | Direct channels | - | - | 1.07 | MSPS |
| | | Multiplexed channels | - | - | 0.8 | |
| | 8-bit sampling rate | Direct channels | - | - | 1.23 | MSPS |
| | | Multiplexed channels | - | - | 0.89 | |
| 6-bit sampling rate | Direct channels | - | - | 1.45 | MSPS | |
| | Multiplexed channels | - | - | 1 | | |

Table 54. ADC characteristics (continued)

| Symbol | Parameter | Conditions | Min | Typ | Max | Unit |
|---------------------------------|--|--|--|-----|---------|--------------------|
| t _S ⁽⁵⁾ | Sampling time | Direct channels 2.4 V ≤ V _{DDA} ≤ 3.6 V | 0.25 | - | - | μs |
| | | Multiplexed channels 2.4 V ≤ V _{DDA} ≤ 3.6 V | 0.56 | - | - | |
| | | Direct channels 1.8 V ≤ V _{DDA} ≤ 2.4 V | 0.56 | - | - | |
| | | Multiplexed channels 1.8 V ≤ V _{DDA} ≤ 2.4 V | 1 | - | - | |
| | | - | 4 | - | 384 | 1/f _{ADC} |
| t _{CONV} | Total conversion time (including sampling time) | f _{ADC} = 16 MHz | 1 | - | 24.75 | μs |
| | | - | 4 to 384 (sampling phase) + 12 (successive approximation) | | | 1/f _{ADC} |
| C _{ADC} | Internal sample and hold capacitor | Direct channels | - | 16 | - | pF |
| | | Multiplexed channels | - | | - | |
| f _{TRIG} | External trigger frequency Regular sequencer | 12-bit conversions | - | - | Tconv+1 | 1/f _{ADC} |
| | | 6/8/10-bit conversions | - | - | Tconv | 1/f _{ADC} |
| f _{TRIG} | External trigger frequency Injected sequencer | 12-bit conversions | - | - | Tconv+2 | 1/f _{ADC} |
| | | 6/8/10-bit conversions | - | - | Tconv+1 | 1/f _{ADC} |
| R _{AIN} ⁽⁶⁾ | Signal source impedance | - | - | - | 50 | kΩ |
| t _{lat} | Injection trigger conversion latency | f _{ADC} = 16 MHz | 219 | - | 281 | ns |
| | | - | 3.5 | - | 4.5 | 1/f _{ADC} |
| t _{latr} | Regular trigger conversion latency | f _{ADC} = 16 MHz | 156 | - | 219 | ns |
| | | - | 2.5 | - | 3.5 | 1/f _{ADC} |
| t _{STAB} | Power-up time | - | - | - | 3.5 | μs |

- The Vref+ input can be grounded if neither the ADC nor the DAC are used (this allows to shut down an external voltage reference).
- The current consumption through VREF is composed of two parameters:
 - one constant (max 300 μA)
 - one variable (max 400 μA), only during sampling time + 2 first conversion pulses
 So, peak consumption is 300+400 = 700 μA and average consumption is 300 + [(4 sampling + 2) / 16] x 400 = 450 μA at 1Msps
- V_{REF+} can be internally connected to V_{DDA} and V_{REF-} can be internally connected to V_{SSA}, depending on the package. Refer to [Section 4: Pin descriptions](#) for further details.
- V_{SSA} or V_{REF-} must be tied to ground.
- Minimum sampling time is reached for an external input impedance limited to a value as defined in [Table 56: Maximum source impedance RAIN max](#).
- External impedance has another high value limitation when using short sampling time as defined in [Table 56: Maximum source impedance RAIN max](#).

Table 55. ADC accuracy⁽¹⁾⁽²⁾

| Symbol | Parameter | Test conditions | Min ⁽³⁾ | Typ | Max ⁽³⁾ | Unit |
|--------|--------------------------------------|--|--------------------|-----|--------------------|------|
| ET | Total unadjusted error | $2.4\text{ V} \leq V_{DDA} \leq 3.6\text{ V}$ $2.4\text{ V} \leq V_{REF+} \leq 3.6\text{ V}$ $f_{ADC} = 8\text{ MHz}$, $R_{AIN} = 50\ \Omega$ $T_A = -40\text{ to }105\text{ }^\circ\text{C}$ | - | | 4 | LSB |
| EO | Offset error | | - | 1 | 2 | |
| EG | Gain error | | - | 1.5 | 3.5 | |
| ED | Differential linearity error | | - | 1 | 2 | |
| EL | Integral linearity error | | - | | 3 | |
| ENOB | Effective number of bits | $2.4\text{ V} \leq V_{DDA} \leq 3.6\text{ V}$ | 9.2 | 10 | - | bits |
| SINAD | Signal-to-noise and distortion ratio | $V_{DDA} = V_{REF+}$ $f_{ADC} = 16\text{ MHz}$, $R_{AIN} = 50\ \Omega$ $T_A = -40\text{ to }105\text{ }^\circ\text{C}$ $F_{input} = 10\text{ kHz}$ | 57.5 | 62 | - | dB |
| SNR | Signal-to-noise ratio | | 57.5 | 62 | - | |
| THD | Total harmonic distortion | | - | -70 | -65 | |
| ENOB | Effective number of bits | | 9.2 | 10 | - | |
| SINAD | Signal-to-noise and distortion ratio | $1.8\text{ V} \leq V_{DDA} \leq 2.4\text{ V}$ $V_{DDA} = V_{REF+}$ $f_{ADC} = 8\text{ MHz or }4\text{ MHz}$, $R_{AIN} = 50\ \Omega$ $T_A = -40\text{ to }105\text{ }^\circ\text{C}$ $F_{input} = 10\text{ kHz}$ | 57.5 | 62 | - | dB |
| SNR | Signal-to-noise ratio | | 57.5 | 62 | - | |
| THD | Total harmonic distortion | | - | -70 | -65 | |
| ENOB | Effective number of bits | | 9.2 | 10 | - | |
| ET | Total unadjusted error | $2.4\text{ V} \leq V_{DDA} \leq 3.6\text{ V}$ $1.8\text{ V} \leq V_{REF+} \leq 2.4\text{ V}$ $f_{ADC} = 4\text{ MHz}$, $R_{AIN} = 50\ \Omega$ $T_A = -40\text{ to }105\text{ }^\circ\text{C}$ | - | 4 | 6.5 | LSB |
| EO | Offset error | | - | 2 | 4 | |
| EG | Gain error | | - | 4 | 6 | |
| ED | Differential linearity error | | - | 1 | 2 | |
| EL | Integral linearity error | | - | 1.5 | 3 | |
| ET | Total unadjusted error | $1.8\text{ V} \leq V_{DDA} \leq 2.4\text{ V}$ $1.8\text{ V} \leq V_{REF+} \leq 2.4\text{ V}$ $f_{ADC} = 4\text{ MHz}$, $R_{AIN} = 50\ \Omega$ $T_A = -40\text{ to }105\text{ }^\circ\text{C}$ | - | 2 | 3 | LSB |
| EO | Offset error | | - | 1 | 1.5 | |
| EG | Gain error | | - | 1.5 | 2 | |
| ED | Differential linearity error | | - | 1 | 2 | |
| EL | Integral linearity error | | - | 1 | 1.5 | |

1. ADC DC accuracy values are measured after internal calibration.
2. ADC accuracy vs. negative injection current: Injecting a negative current on any analog input pins should be avoided as this significantly reduces the accuracy of the conversion being performed on another analog input. It is recommended to add a Schottky diode (pin to ground) to analog pins which may potentially inject negative currents. Any positive injection current within the limits specified for $I_{INJ(PIN)}$ and $\Sigma I_{INJ(PIN)}$ in [Section 6.3.12](#) does not affect the ADC accuracy.
3. Guaranteed by characterization results.

Figure 23. ADC accuracy characteristics

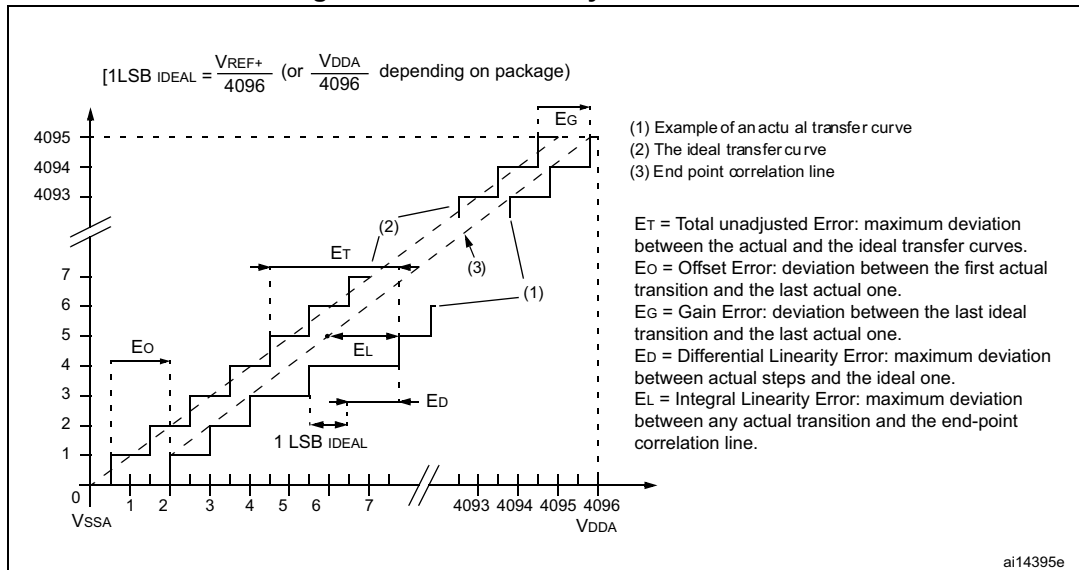
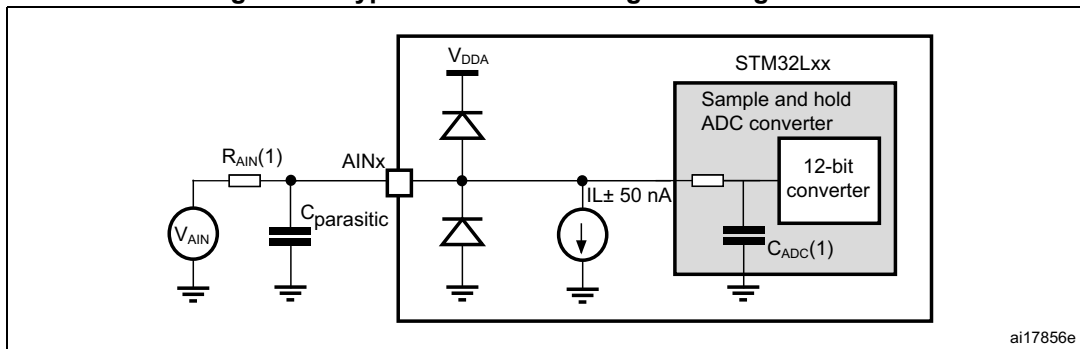

Figure 24. Typical connection diagram using the ADC



1. Refer to [Table 56: Maximum source impedance RAIN max](#) for the value of RAIN and [Table 54: ADC characteristics](#) for the value of CADC.
2. Cparasitic represents the capacitance of the PCB (dependent on soldering and PCB layout quality) plus the pad capacitance (roughly 7 pF). A high Cparasitic value will downgrade conversion accuracy. To remedy this, fADC should be reduced.

Figure 25. Maximum dynamic current consumption on V_{REF+} supply pin during ADC conversion

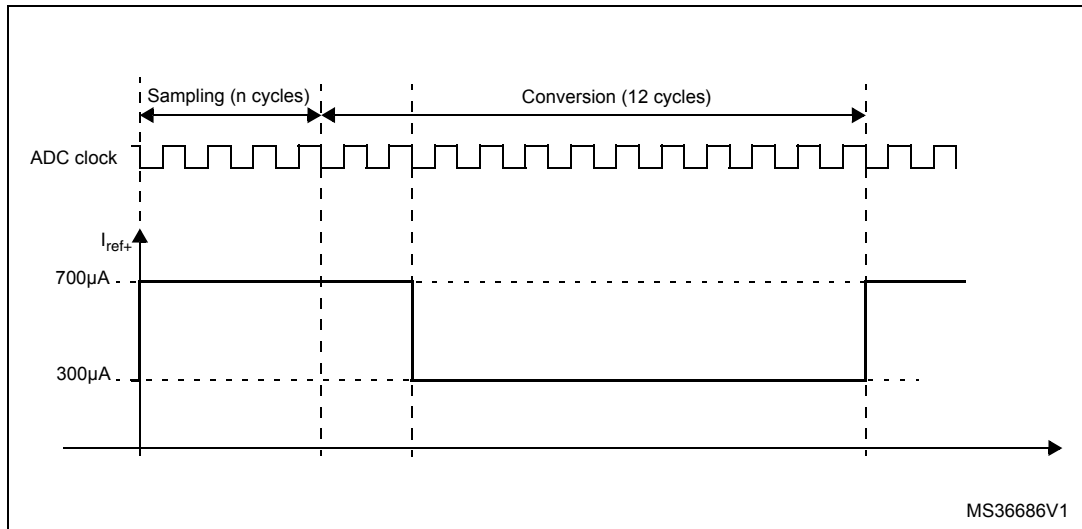

Table 56. Maximum source impedance R_{AIN} max⁽¹⁾

| Ts (µs) | R _{AIN} max (kΩ) | | | | Ts (cycles) f _{ADC} =16 MHz ⁽²⁾ |
|---------|----------------------------------|----------------------------------|----------------------------------|----------------------------------|--|
| | Multiplexed channels | | Direct channels | | |
| | 2.4 V < V _{DDA} < 3.6 V | 1.8 V < V _{DDA} < 2.4 V | 2.4 V < V _{DDA} < 3.6 V | 1.8 V < V _{DDA} < 2.4 V | |
| 0.25 | Not allowed | Not allowed | 0.7 | Not allowed | 4 |
| 0.5625 | 0.8 | Not allowed | 2.0 | 1.0 | 9 |
| 1 | 2.0 | 0.8 | 4.0 | 3.0 | 16 |
| 1.5 | 3.0 | 1.8 | 6.0 | 4.5 | 24 |
| 3 | 6.8 | 4.0 | 15.0 | 10.0 | 48 |
| 6 | 15.0 | 10.0 | 30.0 | 20.0 | 96 |
| 12 | 32.0 | 25.0 | 50.0 | 40.0 | 192 |
| 24 | 50.0 | 50.0 | 50.0 | 50.0 | 384 |

1. Guaranteed by design.
2. Number of samples calculated for f_{ADC} = 16 MHz. For f_{ADC} = 8 and 4 MHz the number of sampling cycles can be reduced with respect to the minimum sampling time Ts (µs),

General PCB design guidelines

Power supply decoupling should be performed as shown in [Figure 7](#). The applicable procedure depends on whether V_{REF+} is connected to V_{DDA} or not. The 100 nF capacitors should be ceramic (good quality). They should be placed as close as possible to the chip.

6.3.18 DAC electrical specifications

Data guaranteed by design, unless otherwise specified.

Table 57. DAC characteristics

| Symbol | Parameter | Conditions | Min | Typ | Max | Unit |
|------------------------|---|---|-----------|-----------|--------------------------|---------------|
| V_{DDA} | Analog supply voltage | - | 1.8 | - | 3.6 | V |
| V_{REF+} | Reference supply voltage | V_{REF+} must always be below V_{DDA} | 1.8 | - | 3.6 | |
| V_{REF-} | Lower reference voltage | - | V_{SSA} | | | |
| $I_{DDVREF+}^{(1)}$ | Current consumption on V_{REF+} supply $V_{REF+} = 3.3\text{ V}$ | No load, middle code (0x800) | - | 130 | 220 | μA |
| | | No load, worst code (0x000) | - | 220 | 350 | |
| $I_{DDA}^{(1)}$ | Current consumption on V_{DDA} supply $V_{DDA} = 3.3\text{ V}$ | No load, middle code (0x800) | - | 210 | 320 | |
| | | No load, worst code (0xF1C) | - | 320 | 520 | |
| R_L | Resistive load | DAC output buffer ON Connected to V_{SSA} | 5 | - | - | k Ω |
| | | DAC output buffer ON Connected to V_{DDA} | 25 | - | - | |
| $C_L^{(2)}$ | Capacitive load | DAC output buffer ON | - | - | 50 | pF |
| R_O | Output impedance | DAC output buffer OFF | 12 | 16 | 20 | k Ω |
| V_{DAC_OUT} | Voltage on DAC_OUT output | DAC output buffer ON | 0.2 | - | $V_{DDA} - 0.2$ | V |
| | | DAC output buffer OFF | 0.5 | - | $V_{REF+} - 1\text{LSB}$ | mV |
| $DNL^{(1)}$ | Differential non linearity ⁽³⁾ | $C_L \leq 50\text{ pF}$, $R_L \geq 5\text{ k}\Omega$ DAC output buffer ON | - | 1.5 | 3 | LSB |
| | | No R_L , $C_L \leq 50\text{ pF}$ DAC output buffer OFF | - | 1.5 | 3 | |
| $INL^{(1)}$ | Integral non linearity ⁽⁴⁾ | $C_L \leq 50\text{ pF}$, $R_L \geq 5\text{ k}\Omega$ DAC output buffer ON | - | 2 | 4 | |
| | | No R_L , $C_L \leq 50\text{ pF}$ DAC output buffer OFF | - | 2 | 4 | |
| Offset ⁽¹⁾ | Offset error at code 0x800 ⁽⁵⁾ | $C_L \leq 50\text{ pF}$, $R_L \geq 5\text{ k}\Omega$ DAC output buffer ON | - | ± 10 | ± 25 | |
| | | No R_L , $C_L \leq 50\text{ pF}$ DAC output buffer OFF | - | ± 5 | ± 8 | |
| Offset1 ⁽¹⁾ | Offset error at code 0x001 ⁽⁶⁾ | No R_L , $C_L \leq 50\text{ pF}$ DAC output buffer OFF | - | ± 1.5 | ± 5 | |



Table 57. DAC characteristics (continued)

| Symbol | Parameter | Conditions | Min | Typ | Max | Unit |
|---------------------------|--|---|-----|--------------|--------------|-------|
| dOffset/dT ⁽¹⁾ | Offset error temperature coefficient (code 0x800) | V _{DDA} = 3.3V V _{REF+} = 3.0V T _A = 0 to 50 °C DAC output buffer OFF | -20 | -10 | 0 | μV/°C |
| | | V _{DDA} = 3.3V V _{REF+} = 3.0V T _A = 0 to 50 °C DAC output buffer ON | 0 | 20 | 50 | |
| Gain ⁽¹⁾ | Gain error ⁽⁷⁾ | C _L ≤ 50 pF, R _L ≥ 5 kΩ DAC output buffer ON | - | +0.1 / -0.2% | +0.2 / -0.5% | % |
| | | No R _L , C _L ≤ 50 pF DAC output buffer OFF | - | +0 / -0.2% | +0 / -0.4% | |
| dGain/dT ⁽¹⁾ | Gain error temperature coefficient | V _{DDA} = 3.3V V _{REF+} = 3.0V T _A = 0 to 50 °C DAC output buffer OFF | -10 | -2 | 0 | μV/°C |
| | | V _{DDA} = 3.3V V _{REF+} = 3.0V T _A = 0 to 50 °C DAC output buffer ON | -40 | -8 | 0 | |
| TUE ⁽¹⁾ | Total unadjusted error | C _L ≤ 50 pF, R _L ≥ 5 kΩ DAC output buffer ON | - | 12 | 30 | LSB |
| | | No R _L , C _L ≤ 50 pF DAC output buffer OFF | - | 8 | 12 | |
| t _{SETTLING} | Settling time (full scale: for a 12-bit code transition between the lowest and the highest input codes till DAC_OUT reaches final value ±1LSB) | C _L ≤ 50 pF, R _L ≥ 5 kΩ | - | 7 | 12 | μs |
| Update rate | Max frequency for a correct DAC_OUT change (95% of final value) with 1 LSB variation in the input code | C _L ≤ 50 pF, R _L ≥ 5 kΩ | - | - | 1 | Msp/s |
| t _{WAKEUP} | Wakeup time from off state (setting the ENx bit in the DAC Control register) ⁽⁸⁾ | C _L ≤ 50 pF, R _L ≥ 5 kΩ | - | 9 | 15 | μs |
| PSRR+ | V _{DDA} supply rejection ratio (static DC measurement) | C _L ≤ 50 pF, R _L ≥ 5 kΩ | - | -60 | -35 | dB |

1. Data based on characterization results.
2. Connected between DAC_OUT and VSSA.
3. Difference between two consecutive codes - 1 LSB.



4. Difference between measured value at Code i and the value at Code i on a line drawn between Code 0 and last Code 4095.
5. Difference between the value measured at Code (0x800) and the ideal value = $V_{REF+}/2$.
6. Difference between the value measured at Code (0x001) and the ideal value.
7. Difference between ideal slope of the transfer function and measured slope computed from code 0x000 and 0xFFFF when buffer is OFF, and from code giving 0.2 V and $(V_{DDA} - 0.2)$ V when buffer is ON.
8. In buffered mode, the output can overshoot above the final value for low input code (starting from min value).

Figure 26. 12-bit buffered /non-buffered DAC

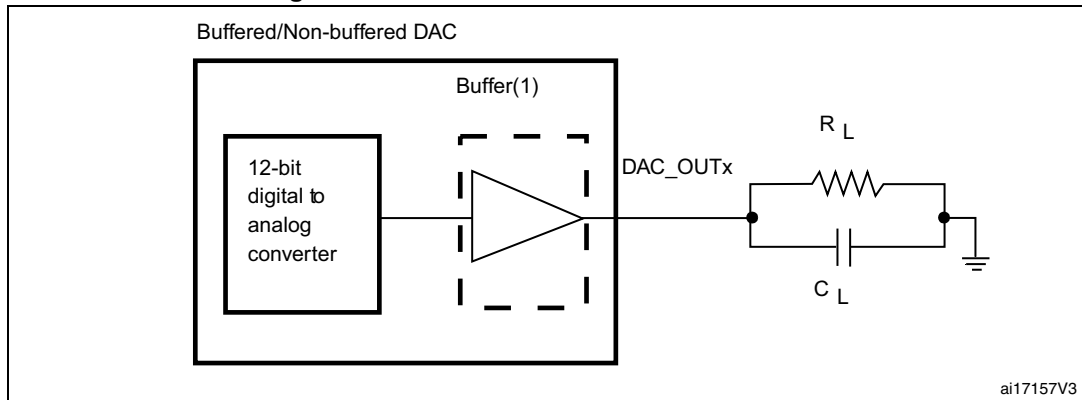

1. The DAC integrates an output buffer that can be used to reduce the output impedance and to drive external loads directly without the use of an external operational amplifier. The buffer can be bypassed by configuring the BOFFx bit in the DAC_CR register.

6.3.19 Operational amplifier characteristics

Table 58. Operational amplifier characteristics

| Symbol | Parameter | | Condition ⁽¹⁾ | Min ⁽²⁾ | Typ | Max ⁽²⁾ | Unit |
|------------------------|------------------------------|---------------------------|--------------------------|--------------------|-----|--------------------|-------------------|
| CMIR | Common mode input range | | - | 0 | - | V_{DD} | |
| V_{I_OFFSET} | Input offset voltage | Maximum calibration range | - | - | - | ± 15 | mV |
| | | After offset calibration | - | - | - | ± 1.5 | |
| ΔV_{I_OFFSET} | Input offset voltage drift | Normal mode | - | - | - | ± 40 | $\mu V/^{\circ}C$ |
| | | Low-power mode | - | - | - | ± 80 | |
| I_{IB} | Input current bias | Dedicated input | 75 °C | - | - | 1 | nA |
| | | General purpose input | | - | - | 10 | |
| I_{LOAD} | Drive current | Normal mode | - | - | - | 500 | μA |
| | | Low-power mode | - | - | - | 100 | |
| I_{DD} | Consumption | Normal mode | No load, quiescent mode | - | 100 | 220 | μA |
| | | Low-power mode | | - | 30 | 60 | |
| CMRR | Common mode rejection ration | Normal mode | - | - | -85 | - | dB |
| | | Low-power mode | - | - | -90 | - | |

Table 58. Operational amplifier characteristics (continued)

| Symbol | Parameter | | Condition ⁽¹⁾ | Min ⁽²⁾ | Typ | Max ⁽²⁾ | Unit | | |
|--------------------|---|----------------|---|-------------------------|------|--------------------|---------------|---|----------|
| PSRR | Power supply rejection ratio | Normal mode | DC | - | -85 | - | dB | | |
| | | Low-power mode | | - | -90 | - | | | |
| GBW | Bandwidth | Normal mode | $V_{DD} > 2.4\text{ V}$ | 400 | 1000 | 3000 | kHz | | |
| | | Low-power mode | | 150 | 300 | 800 | | | |
| | | Normal mode | $V_{DD} < 2.4\text{ V}$ | 200 | 500 | 2200 | | | |
| | | Low-power mode | | 70 | 150 | 800 | | | |
| SR | Slew rate | Normal mode | $V_{DD} > 2.4\text{ V}$ (between 0.1 V and $V_{DD}-0.1\text{ V}$) | - | 700 | - | V/ms | | |
| | | Low-power mode | | $V_{DD} > 2.4\text{ V}$ | - | 100 | | - | |
| | | Normal mode | $V_{DD} < 2.4\text{ V}$ | - | 300 | - | | | |
| | | Low-power mode | | - | 50 | - | | | |
| AO | Open loop gain | Normal mode | | 55 | 100 | - | dB | | |
| | | Low-power mode | | 65 | 110 | - | | | |
| R_L | Resistive load | Normal mode | $V_{DD} < 2.4\text{ V}$ | 4 | - | - | k Ω | | |
| | | Low-power mode | | 20 | - | - | | | |
| C_L | Capacitive load | | - | - | - | 50 | pF | | |
| $V_{OH\text{SAT}}$ | High saturation voltage | Normal mode | $I_{LOAD} = \text{max or } R_L = \text{min}$ | $V_{DD}-100$ | - | - | mV | | |
| | | Low-power mode | | $V_{DD}-50$ | - | - | | | |
| $V_{OL\text{SAT}}$ | Low saturation voltage | Normal mode | | - | - | 100 | | | |
| | | Low-power mode | | - | - | 50 | | | |
| ϕ_m | Phase margin | | | - | - | 60 | | - | $^\circ$ |
| GM | Gain margin | | | - | - | -12 | | - | dB |
| $t_{OFFTRIM}$ | Offset trim time: during calibration, minimum time needed between two steps to have 1 mV accuracy | | - | - | 1 | - | ms | | |
| t_{WAKEUP} | Wakeup time | Normal mode | $C_L \leq 50\text{ pf}, R_L \geq 4\text{ k}\Omega$ | - | 10 | - | μs | | |
| | | Low-power mode | $C_L \leq 50\text{ pf}, R_L \geq 20\text{ k}\Omega$ | - | 30 | - | | | |

1. Operating conditions are limited to junction temperature (0 °C to 105 °C) when V_{DD} is below 2 V. Otherwise to the full ambient temperature range (-40 °C to 85 °C, -40 °C to 105 °C).
2. Guaranteed by characterization results.

6.3.20 Comparator

Table 59. Comparator 1 characteristics

| Symbol | Parameter | Conditions | Min ⁽¹⁾ | Typ | Max ⁽¹⁾ | Unit |
|-------------------------|--|--|--------------------|-----|--------------------|-----------|
| V _{DDA} | Analog supply voltage | - | 1.65 | | 3.6 | V |
| R _{400K} | R _{400K} value | - | - | 400 | - | kΩ |
| R _{10K} | R _{10K} value | - | - | 10 | - | |
| V _{IN} | Comparator 1 input voltage range | - | 0.6 | - | V _{DDA} | V |
| t _{START} | Comparator startup time | - | - | 7 | 10 | μs |
| t _d | Propagation delay ⁽²⁾ | - | - | 3 | 10 | |
| V _{offset} | Comparator offset | - | - | ±3 | ±10 | mV |
| d _{Voffset/dt} | Comparator offset variation in worst voltage stress conditions | V _{DDA} = 3.6 V V _{IN+} = 0 V V _{IN-} = V _{REFINT} T _A = 25 °C | 0 | 1.5 | 10 | mV/1000 h |
| I _{COMP1} | Current consumption ⁽³⁾ | - | - | 160 | 260 | nA |

1. Guaranteed by characterization results.
2. The delay is characterized for 100 mV input step with 10 mV overdrive on the inverting input, the non-inverting input set to the reference.
3. Comparator consumption only. Internal reference voltage not included.

Table 60. Comparator 2 characteristics

| Symbol | Parameter | Conditions | Min | Typ | Max ⁽¹⁾ | Unit |
|---------------------------|---|---|------|-----|--------------------|---------|
| V _{DDA} | Analog supply voltage | - | 1.65 | - | 3.6 | V |
| V _{IN} | Comparator 2 input voltage range | - | 0 | - | V _{DDA} | V |
| t _{START} | Comparator startup time | Fast mode | - | 15 | 20 | μs |
| | | Slow mode | - | 20 | 25 | |
| t _{d slow} | Propagation delay ⁽²⁾ in slow mode | 1.65 V ≤ V _{DDA} ≤ 2.7 V | - | 1.8 | 3.5 | |
| | | 2.7 V ≤ V _{DDA} ≤ 3.6 V | - | 2.5 | 6 | |
| t _{d fast} | Propagation delay ⁽²⁾ in fast mode | 1.65 V ≤ V _{DDA} ≤ 2.7 V | - | 0.8 | 2 | |
| | | 2.7 V ≤ V _{DDA} ≤ 3.6 V | - | 1.2 | 4 | |
| V _{offset} | Comparator offset error | | - | ±4 | ±20 | mV |
| d _{Threshold/dt} | Threshold voltage temperature coefficient | V _{DDA} = 3.3V T _A = 0 to 50 °C V ₋ = V _{REFINT} , 3/4 V _{REFINT} , 1/2 V _{REFINT} , 1/4 V _{REFINT} . | - | 15 | 100 | ppm /°C |
| I _{COMP2} | Current consumption ⁽³⁾ | Fast mode | - | 3.5 | 5 | μA |
| | | Slow mode | - | 0.5 | 2 | |

1. Guaranteed by characterization results.



2. The delay is characterized for 100 mV input step with 10 mV overdrive on the inverting input, the non-inverting input set to the reference.
3. Comparator consumption only. Internal reference voltage (necessary for comparator operation) is not included.

6.3.21 LCD controller

The device embeds a built-in step-up converter to provide a constant LCD reference voltage independently from the V_{DD} voltage. An external capacitor C_{ext} must be connected to the V_{LCD} pin to decouple this converter.

Table 61. LCD controller characteristics

| Symbol | Parameter | Min | Typ | Max | Unit |
|-----------------------|--|------|---------------|-----------|-----------|
| V_{LCD} | LCD external voltage | - | - | 3.6 | V |
| V_{LCD0} | LCD internal reference voltage 0 | - | 2.6 | - | |
| V_{LCD1} | LCD internal reference voltage 1 | - | 2.73 | - | |
| V_{LCD2} | LCD internal reference voltage 2 | - | 2.86 | - | |
| V_{LCD3} | LCD internal reference voltage 3 | - | 2.98 | - | |
| V_{LCD4} | LCD internal reference voltage 4 | - | 3.12 | - | |
| V_{LCD5} | LCD internal reference voltage 5 | - | 3.26 | - | |
| V_{LCD6} | LCD internal reference voltage 6 | - | 3.4 | - | |
| V_{LCD7} | LCD internal reference voltage 7 | - | 3.55 | - | |
| C_{ext} | V_{LCD} external capacitance | 0.1 | - | 2 | μF |
| $I_{LCD}^{(1)}$ | Supply current at $V_{DD} = 2.2 V$ | - | 3.3 | - | μA |
| | Supply current at $V_{DD} = 3.0 V$ | - | 3.1 | - | |
| $R_{Htot}^{(2)}$ | Low drive resistive network overall value | 5.28 | 6.6 | 7.92 | $M\Omega$ |
| $R_L^{(2)}$ | High drive resistive network total value | 192 | 240 | 288 | $k\Omega$ |
| V_{44} | Segment/Common highest level voltage | - | - | V_{LCD} | V |
| V_{34} | Segment/Common 3/4 level voltage | - | $3/4 V_{LCD}$ | - | V |
| V_{23} | Segment/Common 2/3 level voltage | - | $2/3 V_{LCD}$ | - | |
| V_{12} | Segment/Common 1/2 level voltage | - | $1/2 V_{LCD}$ | - | |
| V_{13} | Segment/Common 1/3 level voltage | - | $1/3 V_{LCD}$ | - | |
| V_{14} | Segment/Common 1/4 level voltage | - | $1/4 V_{LCD}$ | - | |
| V_0 | Segment/Common lowest level voltage | 0 | - | - | |
| $\Delta V_{xx}^{(3)}$ | Segment/Common level voltage error $T_A = -40$ to $105^\circ C$ | - | - | ± 50 | mV |

1. LCD enabled with 3 V internal step-up active, 1/8 duty, 1/4 bias, division ratio= 64, all pixels active, no LCD connected.
2. Guaranteed by design.
3. Guaranteed by characterization results.

7 Package information

In order to meet environmental requirements, ST offers this device in different grades of ECOPACK® packages, depending on their level of environmental compliance. ECOPACK® specifications, grade definitions and product status are available at: www.st.com. ECOPACK® is an ST trademark.

7.1 LQFP64, 10 x 10 mm, 64-pin low-profile quad flat package information

Figure 27. LQFP64, 10 x 10 mm, 64-pin low-profile quad flat package outline

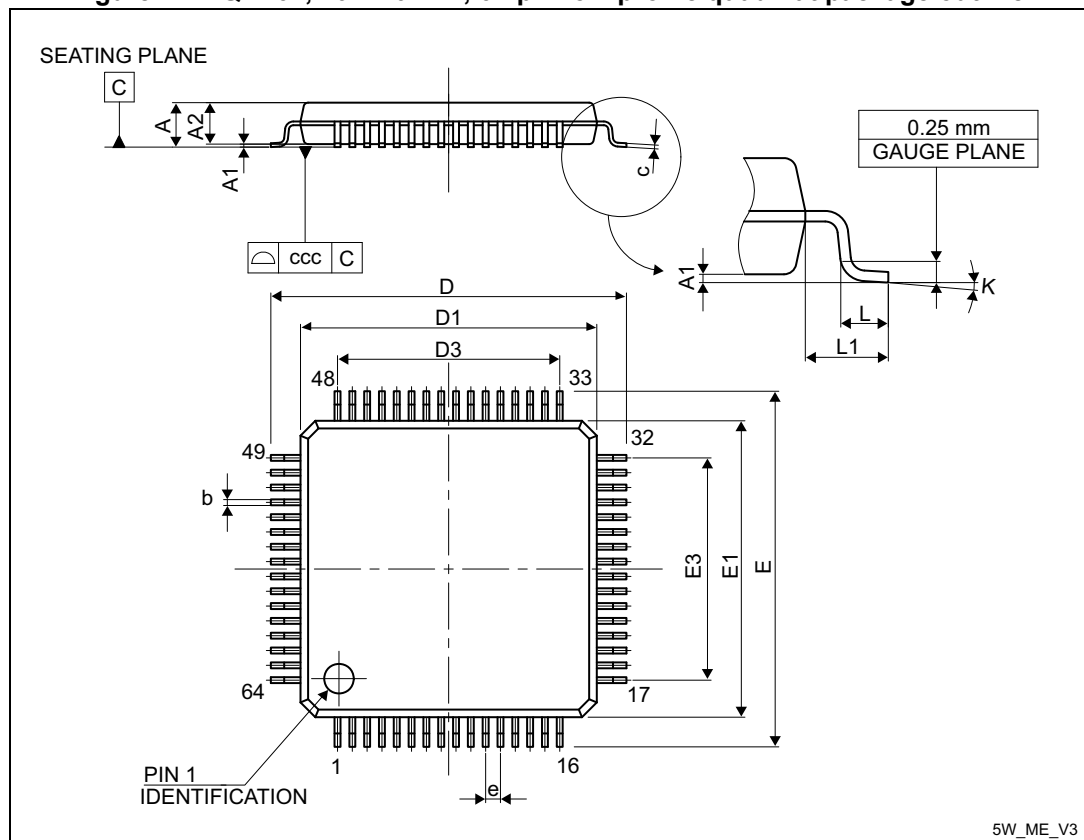

1. Drawing is not to scale.

Table 62. LQFP64, 10 x 10 mm 64-pin low-profile quad flat package mechanical data

| Symbol | millimeters | | | inches ⁽¹⁾ | | |
|--------|-------------|--------|--------|-----------------------|--------|--------|
| | Min | Typ | Max | Min | Typ | Max |
| A | - | - | 1.600 | - | - | 0.0630 |
| A1 | 0.050 | - | 0.150 | 0.0020 | - | 0.0059 |
| A2 | 1.350 | 1.400 | 1.450 | 0.0531 | 0.0551 | 0.0571 |
| b | 0.170 | 0.220 | 0.270 | 0.0067 | 0.0087 | 0.0106 |
| c | 0.090 | - | 0.200 | 0.0035 | - | 0.0079 |
| D | 11.800 | 12.000 | 12.200 | 0.4646 | 0.4724 | 0.4803 |
| D1 | 9.800 | 10.000 | 10.200 | 0.3858 | 0.3937 | 0.4016 |
| D3 | - | 7.500 | - | - | 0.2953 | - |
| E | 11.800 | 12.000 | 12.200 | 0.4646 | 0.4724 | 0.4803 |
| E1 | 9.800 | 10.000 | 10.200 | 0.3858 | 0.3937 | 0.4016 |
| E3 | - | 7.500 | - | - | 0.2953 | - |
| e | - | 0.500 | - | - | 0.0197 | - |
| L | 0.450 | 0.600 | 0.750 | 0.0177 | 0.0236 | 0.0295 |
| L1 | - | 1.000 | - | - | 0.0394 | - |
| ccc | - | - | 0.080 | - | - | 0.0031 |
| K | 0.0 | 3.5 | 7.0 | 0.0 | 3.5 | 7.0 |

1. Values in inches are converted from mm and rounded to 4 decimal digits.

Figure 28. LQFP64 Recommended footprint

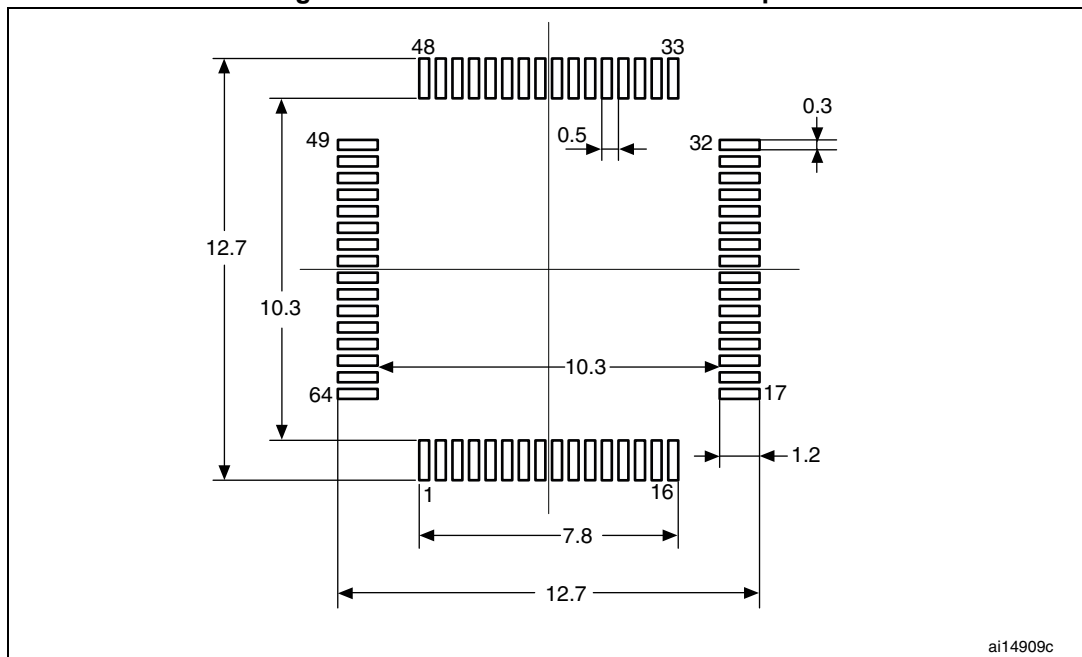

1. Dimensions are in millimeters.

LQFP64 device marking

The following figure gives an example of topside marking orientation versus pin 1 identifier location.

Other optional marking or inset/upset marks, which identify the parts throughout supply chain operations, are not indicated below.

Figure 29. LQFP64 device marking example

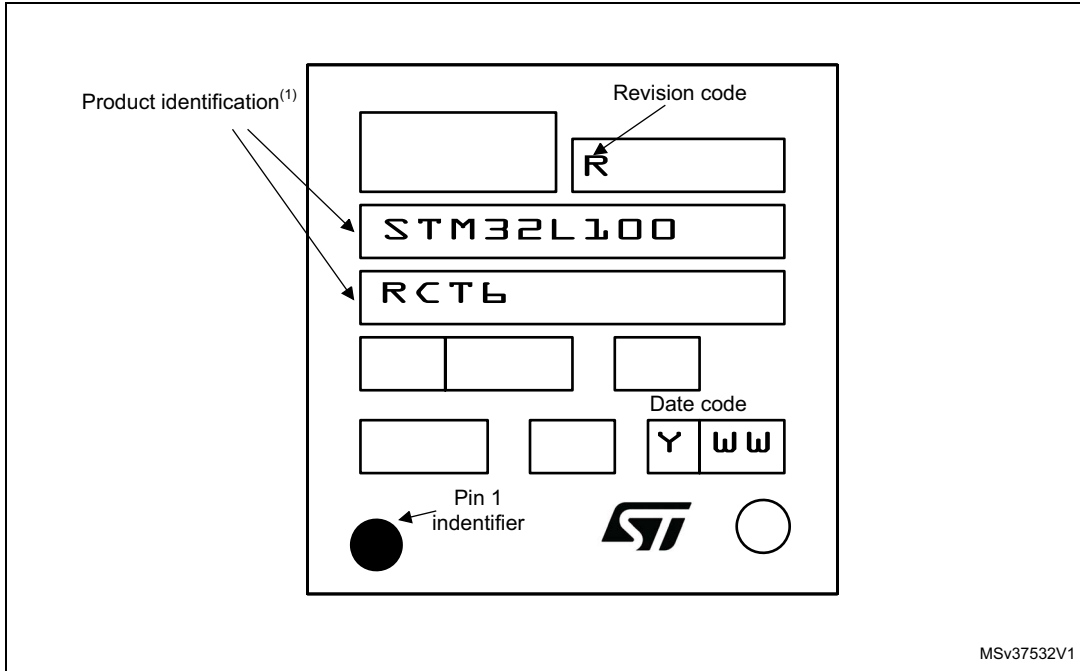

1. Parts marked as ES or E or accompanied by an engineering sample notification letter are not yet qualified and therefore not approved for use in production. ST is not responsible for any consequences resulting from such use. In no event will ST be liable for the customer using any of these engineering samples in production. ST's Quality department must be contacted prior to any decision to use these engineering samples to run a qualification activity.

7.2 Thermal characteristics

The maximum chip-junction temperature, $T_J \text{ max}$, in degrees Celsius, may be calculated using the following equation:

$$T_J \text{ max} = T_A \text{ max} + (P_D \text{ max} \times \Theta_{JA})$$

Where:

- $T_A \text{ max}$ is the maximum ambient temperature in °C,
- Θ_{JA} is the package junction-to-ambient thermal resistance, in °C/W,
- $P_D \text{ max}$ is the sum of $P_{INT \text{ max}}$ and $P_{I/O \text{ max}}$ ($P_D \text{ max} = P_{INT \text{ max}} + P_{I/O \text{ max}}$),
- $P_{INT \text{ max}}$ is the product of I_{DD} and V_{DD} , expressed in Watts. This is the maximum chip internal power.

$P_{I/O \text{ max}}$ represents the maximum power dissipation on output pins where:

$$P_{I/O \text{ max}} = \sum (V_{OL} \times I_{OL}) + \sum ((V_{DD} - V_{OH}) \times I_{OH}),$$

taking into account the actual V_{OL} / I_{OL} and V_{OH} / I_{OH} of the I/Os at low and high level in the application.

Table 63. Thermal characteristics

| Symbol | Parameter | Value | Unit |
|---------------|---|-------|------|
| Θ_{JA} | Thermal resistance junction-ambient LQFP64 - 10 x 10 mm / 0.5 mm pitch | 46 | °C/W |

Figure 30. Thermal resistance suffix 6

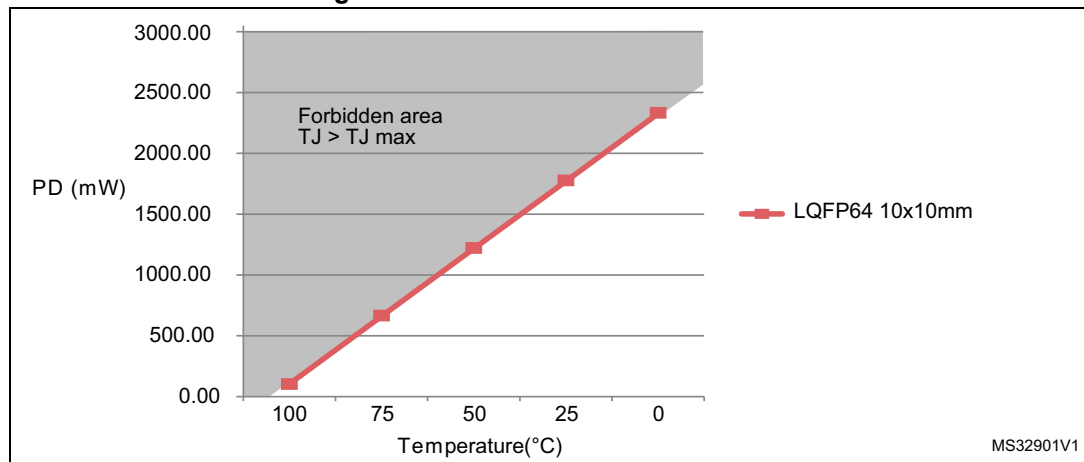
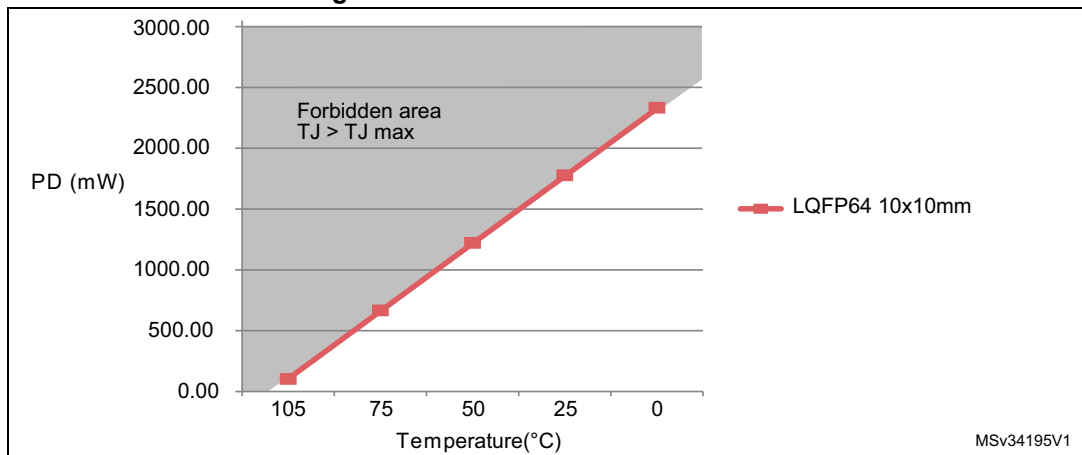

Figure 31. Thermal resistance suffix 7



7.2.1 Reference document

JESD51-2 Integrated Circuits Thermal Test Method Environment Conditions - Natural Convection (Still Air). Available from www.jedec.org.

8 Ordering information

Table 64. STM32L100RC ordering information scheme

| Example: | STM32 | L | 100 | R | C | T | 6 | TR |
|--|-------|---|-----|---|---|---|---|----|
| Device family | | | | | | | | |
| STM32 = ARM-based 32-bit microcontroller | | | | | | | | |
| Product type | | | | | | | | |
| L = Low power | | | | | | | | |
| Device subfamily | | | | | | | | |
| 100: Device with LCD | | | | | | | | |
| Pin count | | | | | | | | |
| R = 64 pins | | | | | | | | |
| Flash memory size | | | | | | | | |
| C = 256 Kbytes of Flash memory | | | | | | | | |
| Package | | | | | | | | |
| T = LQFP | | | | | | | | |
| Temperature range | | | | | | | | |
| 6 = Industrial temperature range, -40 to 85 °C | | | | | | | | |
| 7 = Industrial temperature range, -40 to 105°C | | | | | | | | |
| Packing | | | | | | | | |
| TR = tape and reel | | | | | | | | |
| No character = tray or tube | | | | | | | | |

For a list of available options (speed, package, etc.) or for further information on any aspect of this device, please contact your nearest ST sales office.

9 Revision history

Table 65. Document revision history

| Date | Revision | Changes |
|-------------|----------|---|
| 25-Jul-2013 | 1 | Initial release. |
| 25-Jun-2014 | 2 | Updated electrical characteristics Updated the conditions in Table 24: Low-power mode wakeup timings . Removed ambiguity of “ambient temperature” in the electrical characteristics description. |
| 12-Sep-2014 | 3 | Updated communication interfaces section including I2S characteristics. Updated DMIPS features in cover page and description section. Updated Table 7: STM32L100RC pin definitions with additional functions column. Updated Table 18: Current consumption in Sleep mode Flash ON, OFF mode. Updated table: ADC Maximum source impedance, RAIN max. |
| 09-Mar-2015 | 4 | Updated Section 7: Package information with new package device marking. Updated Figure 4: Memory map . |

Table 65. Document revision history (continued)

| Date | Revision | Changes |
|-------------|----------|--|
| 28-Aug-2017 | 5 | <p>Updated Table 41: I/O static characteristics pull-up and pull-down values.</p> <p>Updated Table 44: NRST pin characteristics pull-up values.</p> <p>Updated Section 7: Package information adding information about other optional marking or inset/upset marks.</p> <p>Updated note 1 below all the package device marking figures.</p> <p>Updated Section 7: Package information replacing “Marking of engineering samples” by “device marking”.</p> <p>Updated all the notes, removing ‘not tested in production’.</p> <p>Updated Nested vectored interrupt controller (NVIC) in Section 3.2: ARM® Cortex®-M3 core with MPU about process state automatically saved.</p> <p>Updated Table 2: Functionalities depending on the operating power supply range removing I/O operation column and adding note about GPIO speed.</p> <p>Updated Table 40: I/O current injection susceptibility note by ‘injection is not possible’.</p> <p>Updated Figure 15: Recommended NRST pin protection note about the 0.1uF capacitor.</p> <p>Updated cover page putting eight SPIs in the peripheral communication interface list.</p> <p>Updated Table 4: Functionalities depending on the working mode (from Run/active down to standby) LSI and LSE functionalities putting “Y” in Standby mode.</p> <p>Removed note 1 below Figure 2: Clock tree.</p> <p>Updated Table 9: Voltage characteristics adding note about VREF- pin.</p> <p>Updated Table 38: ESD absolute maximum ratings CDM class.</p> <p>Updated Table 57: DAC characteristics resistive load.</p> <p>Updated Section 3.1: Low-power modes Low-power run mode (MSI) RC oscillator clock.</p> <p>Updated Table 4: Functionalities depending on the working mode (from Run/active down to standby) disabling I2C functionality in Low-power Run and Low-power Sleep modes.</p> |

IMPORTANT NOTICE – PLEASE READ CAREFULLY

STMicroelectronics NV and its subsidiaries ("ST") reserve the right to make changes, corrections, enhancements, modifications, and improvements to ST products and/or to this document at any time without notice. Purchasers should obtain the latest relevant information on ST products before placing orders. ST products are sold pursuant to ST's terms and conditions of sale in place at the time of order acknowledgement.

Purchasers are solely responsible for the choice, selection, and use of ST products and ST assumes no liability for application assistance or the design of Purchasers' products.

No license, express or implied, to any intellectual property right is granted by ST herein.

Resale of ST products with provisions different from the information set forth herein shall void any warranty granted by ST for such product.

ST and the ST logo are trademarks of ST. All other product or service names are the property of their respective owners.

Information in this document supersedes and replaces information previously supplied in any prior versions of this document.

© 2017 STMicroelectronics – All rights reserved

单击下面可查看定价，库存，交付和生命周期等信息

[>>STMicroelectronics\(意法半导体\)](#)