

## Features

- Senses Bus Voltages From 0V to 36V
- High-Side or Low-Side Sensing
- Reports Current, Voltage, and Power
- High Accuracy
- Configurable Averaging Options
- 16 Programmable Addresses
- Operates from 2.7-V to 5.5-V Power Supply
- 10-Pin, MSOP Package

## Description

The TPA620 is a current and power monitor, with I2C or SMBUS-compatible interface. The device monitors both a shunt voltage drop and bus supply voltage.

The TPA620 common mode input voltage can vary from 0V to 36V.

The TPA620 features up to 16 programmable addresses on the I2C-compatible interface.

## Applications

- Power management
- Servers
- Telecom Equipment
- Computing
- Test Equipment

## Function block diagram

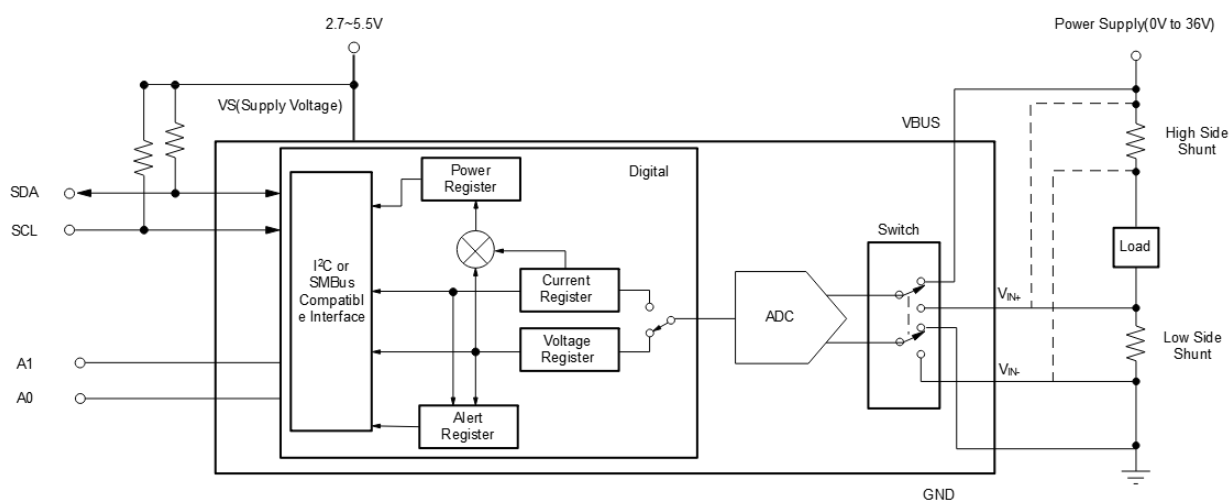

**Figure 1** Function block diagram

## Table of Contents

<b>Features</b> .....	<b>1</b>
<b>Applications</b> .....	<b>1</b>
<b>Description</b> .....	<b>1</b>
<b>Function block diagram</b> .....	<b>1</b>
<b>Table of Contents</b> .....	<b>2</b>
<b>Revision History</b> .....	<b>3</b>
<b>Pin Configuration and Functions</b> .....	<b>4</b>
Pin Functions .....	4
<b>Order Information</b> .....	<b>4</b>
<b>Specifications</b> .....	<b>5</b>
Absolute Maximum Ratings .....	5
ESD, Electrostatic Discharge Protection .....	5
Thermal Information .....	5
Electrical Characteristics .....	6
Typical Performance Characteristics .....	8
<b>Detail description</b> .....	<b>10</b>
Overview .....	10
Serial Bus Interface .....	10
Register Maps .....	11
Feature Description .....	11
<b>Package Information</b> .....	<b>17</b>

## Revision History

Date	Revision	Notes
2020-6-10	Rev.A.01	1.0 Version.
2021-5-25	Rev.A.02	Update diagram.
2021-11-10	Rev.A.03	Update I2C address table, add note of configuration register.
2021-11-16	Rev.A.04	Correct typo of package name.
2022-12-15	Rev.A.05	Update block diagram.
2022-12-30	Rev.A.06	Correct typo of power unit from mA to $\mu$ A.

## Pin Configuration and Functions

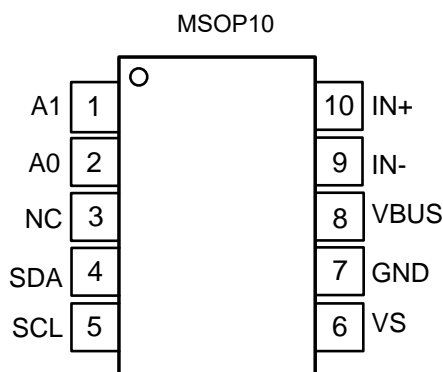

**Figure 2 Pin Map**

## Pin Functions

Pin		I/O	Description
2	A0	Digital input	Address pin. Connect to GND, SCL, SDA, or VS.
1	A1	Digital input	Address pin. Connect to GND, SCL, SDA, or VS.
3	NC	NA	NC
7	GND	Analog	Ground.
10	IN+	Analog input	Connect to supply side of shunt resistor.
9	IN-	Analog input	Connect to load side of shunt resistor.
5	SCL	Digital input	Serial bus clock line, open-drain input.
4	SDA	Digital I/O	Serial bus data line, open-drain input/output.
8	VBUS	Analog input	Bus voltage input.
6	V <sub>s</sub>	Analog	Power supply, 2.7 V to 5.5 V.

## Order Information

Order Number	Package	Marking Information	MSL	Transport Media, Quantity
TPA620-VR-S	MSOP10	TPA620	1	Tape and Reel, 3000

## Specifications

### Absolute Maximum Ratings

over operating free-air temperature range (unless otherwise noted) <sup>(1)</sup>

Parameters		Value	Unit
$V_S$	Supply voltage	6.0	V
Analog Inputs, IN+, IN-	Differential ( $V_{IN+} - V_{IN-}$ ) <sup>(2)</sup>	-40 to 40	V
	Common-Mode ( $(V_{IN+} + V_{IN-}) / 2$ )	-0.3 to 40	V
$V_{VBUS}$		-0.3 to 40	V
$V_{SDA}$		GND - 0.3 to 6	V
$V_{SCL}$		GND - 0.3 to $V_{VS} + 0.3$	V
$I_{IN}$	Input current into any pin	5	mA
$I_{OUT}$	Open-drain digital output current	10	mA
$T_J$	Junction Temperature	150	°C
$T_{STG}$	Storage Temperature Range	-65 to 150	°C

(1) Stresses beyond those listed under Absolute Maximum Ratings may cause permanent damage to the device. These are stress ratings only, which do not imply functional operation of the device at these or any other conditions beyond those indicated under Recommended Operating Conditions. Exposure to absolute-maximum-rated conditions for extended periods may affect device reliability.

(2) IN+ and IN- may have a differential voltage between -40 V and 40 V. However, the voltage at these pins must not exceed the range -0.3 V to 40 V.

### ESD, Electrostatic Discharge Protection

Parameter		Condition	Minimum Level	Unit
HBM	Human Body Model ESD	ANSI/ESDA/JEDEC JS-001	±2	kV
CDM	Charged Device Model ESD	ANSI/ESDA/JEDEC JS-002	±1	kV

### Thermal Information

Package Type	$\theta_{JA}$	$\theta_{JC}$	Unit
MSOP10	171	42.9	°C/W

## Electrical Characteristics

$T_A = 25^\circ\text{C}$ ,  $V_{VS} = 3.3\text{ V}$ ,  $V_{IN+} = 12\text{ V}$ ,  $V_{SHUNT} = (V_{IN+} - V_{IN-}) = 32\text{ mV}$ ,  $V_{VBUS} = 12\text{ V}$ ,  $\text{PGA} = /1$ , and  $\text{BRNG}^{(1)} = 1$ , unless otherwise noted.

Parameter		Conditions	Min.	Typ.	Max.	Unit
<b>Input</b>						
Shunt voltage input range		PGA=/1	-40		40	mV
		PGA=/2	-80		80	mV
		PGA=/4	-160		160	mV
		PGA=/8	-320		320	mV
Bus voltage input range <sup>(1)</sup>		BRNG = 1	0		32	V
		BRNG = 0	0		16	
CMRR	Common-mode rejection	$0\text{ V} \leq V_{IN+} \leq 36\text{ V}$	110			dB
VOS Shunt offset voltage, RTI <sup>(2)</sup>		PGA=/1		±2.5	±50	μV
		PGA=/2				
		PGA=/4		±2.5	±75	μV
		PGA=/8				
Shunt offset voltage, RTI <sup>(2)</sup> vs temperature		$-40^\circ\text{C} \leq T_A \leq 125^\circ\text{C}$		0.15		μV/°C
Shunt offset voltage, RTI <sup>(2)</sup> vs Power supply		$2.7\text{ V} \leq V_S \leq 5.5\text{ V}$		5		μV/V
VOS Bus offset voltage, RTI <sup>(2)</sup>				±1.25	±30	mV
Bus offset voltage, RTI <sup>(2)</sup> vs temperature		$-40^\circ\text{C} \leq T_A \leq 125^\circ\text{C}$		30		μV/°C
Bus offset voltage, RTI <sup>(2)</sup> vs power				2		mV/V
IB Input bias current				10		μA
VBUS input impedance				325		kΩ
Input leakage (3)		(IN+ pin) + (IN- pin), Power-down mode		1		μA
<b>DC Accuracy</b>						
ADC native resolution				12		Bits
1 LSB step size		Shunt voltage		10		μV
		Bus voltage		4		mV
Shunt voltage gain error				0.02%	0.40%	
Shunt voltage gain error vs temperature		$-40^\circ\text{C} \leq T_A \leq 125^\circ\text{C}$		50		ppm/°C
Bus voltage gain error				0.02%	0.40%	
Bus voltage gain error vs temperature		$-40^\circ\text{C} \leq T_A \leq 125^\circ\text{C}$		50		ppm/°C
$t_{CT}$	ADC conversion time	12 bit		542		μs
		11 bit		269		μs
		10 bit		134		μs
		9 bit		66		μs

**Electrical Characteristics (continued)**
 $T_A = 25^\circ\text{C}$ ,  $V_{VS} = 3.3\text{ V}$ ,  $V_{IN+} = 12\text{ V}$ ,  $V_{SHUNT} = (V_{IN+} - V_{IN-}) = 32\text{ mV}$ ,  $V_{VBUS} = 12\text{ V}$ ,  $PGA = /1$ , and  $BRNG^{(1)} = 1$ , unless otherwise noted.

Parameter	Conditions	Min.	Typ.	Max.	Unit
<b>SMBus</b>					
SMBus timeout <sup>(4)</sup>			28		ms

Parameter	Conditions	Min.	Typ.	Max.	Unit
Input capacitance			3		
Leakage input current	$0\text{ V} \leq V_{SCL} \leq V_{VS}$ $0\text{ V} \leq V_{SDA} \leq V_{VS}$ $0\text{ V} \leq V_{Alert} \leq V_{VS}$ $0\text{ V} \leq V_{A0} \leq V_{VS}$ $0\text{ V} \leq V_{A1} \leq V_{VS}$		0.1		$\mu\text{A}$
$V_{IH}$	High-level input voltage		$0.7 \times V_{VS}$	$0.3 \times V_{VS}$	V
$V_{IL}$	Low-level input voltage			0.4	V
$V_{OL}$	Low-level output voltage, SDA, Alert	$I_{OL} = 3\text{ mA}$	0	0.4	V
Hysteresis			150		mV
Operating supply range		2.7		5.5	V
$I_Q$	Quiescent current		1100		$\mu\text{A}$
	Quiescent current, power-down (shutdown) mode		8		$\mu\text{A}$
$V_{POR}$	Power-on reset threshold		2.2		V

(1) This parameter only expresses the full-scale range of the ADC scaling.

(2) RTI = Referred-to-input.

(3) Input leakage is positive (current flowing into the pin) for the conditions shown at the top of this table. Negative leakage currents can occur under different input conditions.

(4) SMBus timeout in the TPA620 resets the interface any time SCL is low for more than 28ms.

Typical Performance Characteristics

$T_A = 25^\circ\text{C}$ ,  $V_{VS} = 3.3\text{ V}$ ,  $V_{IN+} = 12\text{ V}$ ,  $V_{SHUNT} = (V_{IN+} - V_{IN-}) = 32\text{ mV}$ ,  $V_{VBUS} = 12\text{ V}$ ,  $PGA = /1$ , and  $BRNG^{(1)} = 1$ , unless otherwise noted.

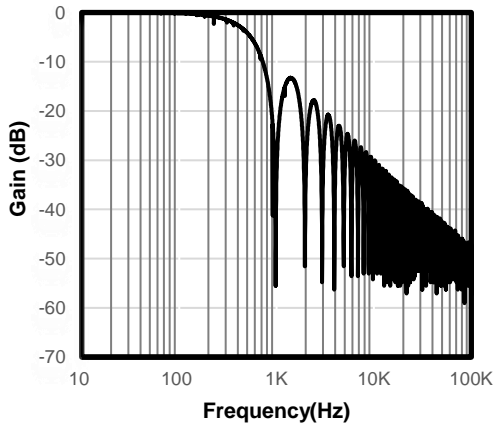

Figure 3

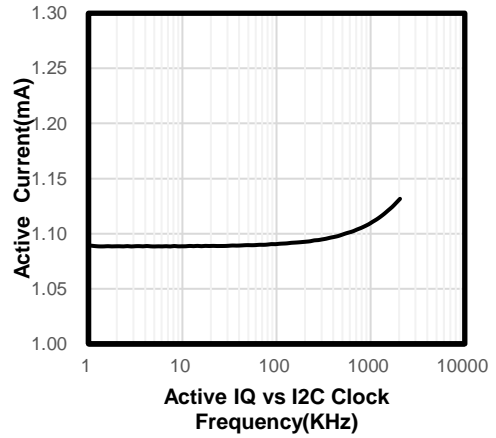

Figure 4

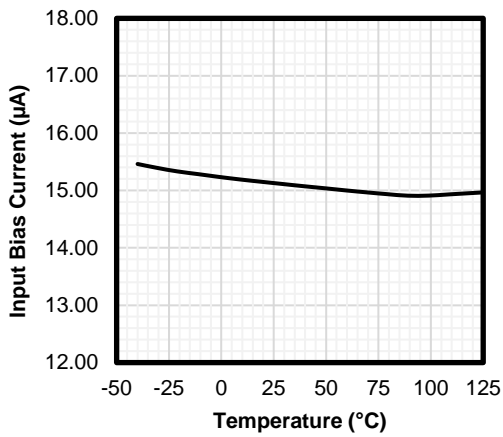

Figure 5

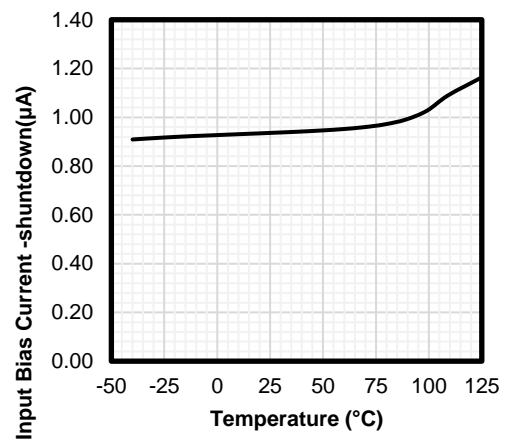

Figure 6

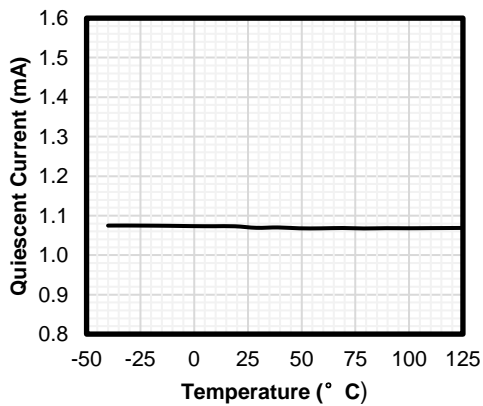

Figure 7

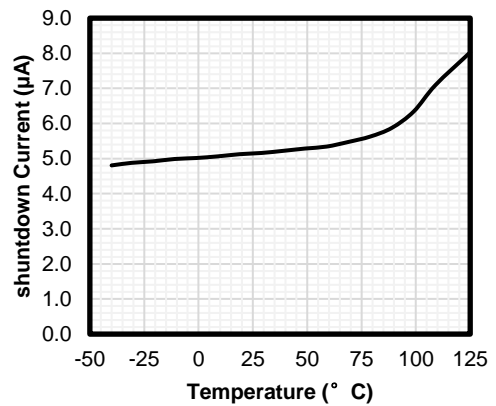

Figure 8



Typical Performance Characteristics (continued)

$T_A = 25^\circ\text{C}$ ,  $V_{VS} = 3.3\text{ V}$ ,  $V_{IN+} = 12\text{ V}$ ,  $V_{SHUNT} = (V_{IN+} - V_{IN-}) = 32\text{ mV}$ ,  $V_{VBUS} = 12\text{ V}$ ,  $PGA = /1$ , and  $BRNG^{(1)} = 1$ , unless otherwise noted.

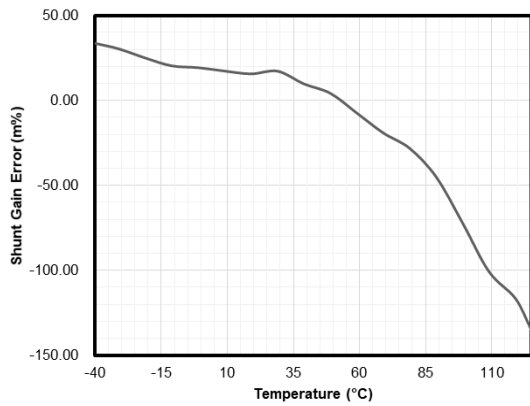

Figure 9

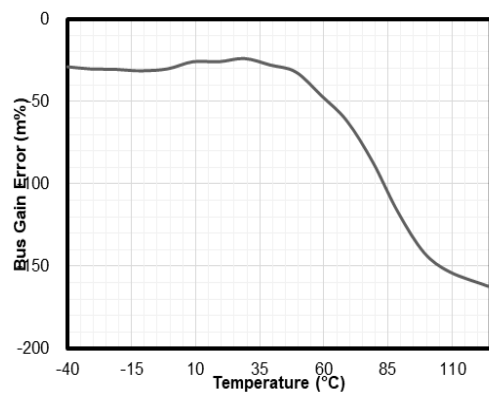

Figure 10

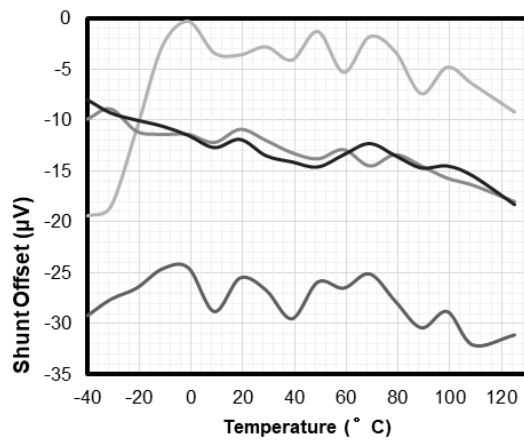

Figure 11

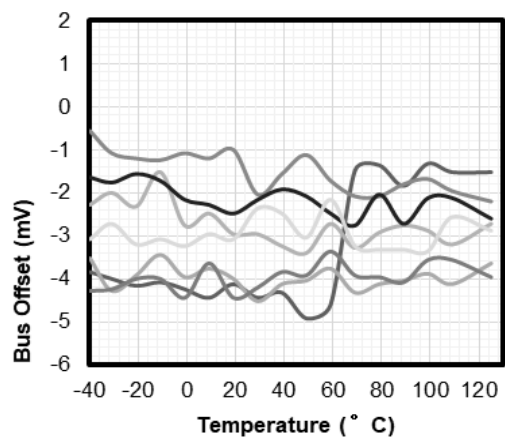

Figure 12

## Detail description

### Overview

The TPA620 is a digital current sense amplifier with an I2C- and SMBus-compatible interface. It performs two measurements on the power-supply bus: The differential shunt voltage created by load current flowing through a shunt resistor is measured at the IN+ and IN- pins. And the power supply bus voltage is measured at the VBUS pin.

### Serial Bus Interface

TPA620 has two I2C address pins, A0 and A1. 16 addresses are available by connecting A0 and A1 to different logic levels. At beginning of I2C communication, the states of A0 and A1 are sampled by the chip to set the I2C address. Following is the address table

*Table 1 I2C Address Table*

A1	A0	SLAVE ADDRESS
GND	GND	1000000
GND	V <sub>S</sub>	1000001
GND	SDA	1000010
GND	SCL	1000011
V <sub>S</sub>	GND	1000100
V <sub>S</sub>	V <sub>S</sub>	1000101
V <sub>S</sub>	SDA	1000110
V <sub>S</sub>	SCL	1000111
SDA	GND	1001000
SDA	V <sub>S</sub>	1001001
SDA	SDA	1001010
SDA	SCL	1001011
SCL	GND	1001100
SCL	V <sub>S</sub>	1001101
SCL	SDA	1001110
SCL	SCL	1001111

## Register Maps

**Table 2 Register Map**

Pointer Address	Register Name	Function	Power On Reset		Type <sup>(1)</sup>
			Binary	Hex	
00	Configuration	All-register reset, settings for bus voltage range, PGA gain, ADC resolution/averaging.	00111001 10011111	399F	R/W
01	Shunt voltage	Shunt voltage measurement data.	Shunt voltage	—	R
02	Bus voltage	Bus voltage measurement data.	Bus voltage	—	R
03	Power <sup>(2)</sup>	Power measurement data.	00000000 00000000	0000	R
04	Current <sup>(2)</sup>	Contains the value of the current flowing through the shunt resistor.	00000000 00000000	0000	R
05	Calibration	Sets full-scale range and LSB of current and power measurements. Overall system calibration.	00000000 00000000	0000	R/W

(1) Values based on a statistical analysis of a one-time sample of devices. Minimum and maximum values are not ensured and not production tested. Condition: A0=A1=0.

Type: R = Read only, R/W = Read/Write.

(2) The Power register and Current register default to 0 because the Calibration register defaults to 0, yielding a zero current value until the Calibration register is programmed.

## Feature Description

All TPA620 registers 16-bit registers are actually two 8-bit bytes through the I<sup>2</sup>C- or SMBUS-compatible interface.

### Configuration Register (address = 00h) [reset = 399Fh]

**Table 3 Configuration Register**

15	14	13	12	11	10	9	8	7	6	5	4	3	2	1	0
RST	—	BRN G	PG1	PG0	BADC 4	BADC 3	BADC 2	BADC 1	SADC 4	SADC 3	SADC 2	SADC 1	MODE 3	MODE 2	MODE 1
R/W -0	R/W -0	R/W- 1	R/W -1	R/W -1	R/W-0	R/W-0	R/W-1	R/W-1	R/W-0	R/W-0	R/W-1	R/W-1	R/W-1	R/W-1	R/W-1

Note1: R/W = Read/Write; R = Read only; -n = value after reset.

Note2: When a ADC measurement process is running, writing to this register will interrupt the current process and restart ADC measurement with the latest register configuration.

#### RST: Reset Bit

Bit 15 Setting this bit to 1 generates a system reset that is the same as power-on reset. Resets all registers to default values; this bit self-clears.

#### BRNG: Bus Voltage Range

Bit 13 0 = 16-V FSR

1 = 32-V FSR (default value)

#### PG: PGA (Shunt Voltage Only)

Bits 11, 12 Sets PGA gain and range. Note that the PGA defaults to +8 (320-mV range). Table 3 shows the gain and range for the various product gain settings.

**Table 4 PG Bit Settings [12:11] <sup>(1)</sup>**

PG1	PG0	GAIN	RANGE
0	0	1	±40 mV
0	1	/2	±80 mV
1	0	/4	±160 mV
1	1	/8	±320 mV

(1) Shaded values are default.

**BADC: BADC Bus ADC Resolution/Averaging**

Bits 7–10: These bits adjust the Bus ADC resolution (9-, 10-, 11-, or 12-bit) or set the number of samples used when averaging results for the Bus Voltage Register (02h).

**SADC: SADC Shunt ADC Resolution/Averaging**

Bits 3–6: These bits adjust the Shunt ADC resolution (9-, 10-, 11-, or 12-bit) or set the number of samples used when averaging results for the Shunt Voltage Register (01h).

BADC (Bus) and SADC (Shunt) ADC resolution/averaging and conversion time settings are shown in Table 4.

**Table 5 ADC Settings (SADC [6:3], BADC [10:7])<sup>(1)</sup>**

ADC4	ADC3	ADC2	ADC1	Mode/Samples	Conversion Time
0	X <sup>(2)</sup>	0	0	9-bit	66µs
0	X <sup>(2)</sup>	0	1	10-bit	134µs
0	X <sup>(2)</sup>	1	0	11-bit	269µs
0	X <sup>(2)</sup>	1	1	12-bit	542µs
1	0	0	0	12-bit	542 µs
1	0	0	1	2	1.08 mS
1	0	1	0	4	2.17 mS
1	0	1	1	8	4.34 mS
1	1	0	0	16	8.67 mS
1	1	0	1	32	17.3 mS
1	1	1	0	64	34.7 mS
1	1	1	1	128	69.4 mS

(1) Shaded values are default.

(2) X = Don't care

**MODE: Operating Mode**

Bits 0-2: Selects continuous, triggered, or power-down mode of operation. These bits default to continuous shunt and bus measurement mode. The mode settings are shown in Table 5.

**Table 6 Mode Settings [2:0] <sup>(1)</sup>**

MODE3	MODE2	MODE1	MODE
0	0	0	Power-down
0	0	1	Shunt voltage, triggered
0	1	0	Bus voltage, triggered
0	1	1	Shunt and bus, triggered
1	0	0	ADC off (disabled)
1	0	1	Shunt voltage, continuous
1	1	0	Bus voltage, continuous
1	1	1	Shunt and bus, continuous

(1) Shaded values are default.

## Data Output Registers

### Shunt Voltage Register (address = 01h)

The Shunt Voltage register stores the current shunt voltage reading,  $V_{SHUNT}$ . Shunt Voltage register bits are shifted according to the PGA setting selected in the Configuration register (00h). When multiple sign bits are present, they are all the same value. Negative numbers are represented in 2's complement format. Generate the 2's complement of a negative number by complementing the absolute value binary number and adding 1. Extend the sign, denoting a negative number by setting the MSB = 1. Extend the sign to any additional sign bits to form the 16-bit word.

**Table 7 Shunt Voltage Register at PGA = /8**

At PGA = /8, full-scale range =  $\pm 320$  mV (decimal = 32000). For  $V_{SHUNT} = +320$  mV, Value = 7D00h; For  $V_{SHUNT} = -320$  mV, Value = 8300h; and LSB = 10  $\mu$ V.

15	14	13	12	11	10	9	8	7	6	5	4	3	2	1	0
SIG	SD14	SD13	SD12	SD11	SD1	SD9	SD8	SD7	SD6	SD5	SD4	SD3	SD2	SD1	SD0
N	_8	_8	_8	_8	0_8	_8	_8	_8	_8	_8	_8	_8	_8	_8	_8

**Table 8 Shunt Voltage Register at PGA = /4**

At PGA = /4, full-scale range =  $\pm 160$  mV (decimal = 16000). For  $V_{SHUNT} = +160$  mV, Value = 3E80h; For  $V_{SHUNT} = -160$  mV, Value = C180h; and LSB = 10  $\mu$ V.

15	14	13	12	11	10	9	8	7	6	5	4	3	2	1	0
SIG	SIGN	SD13_	SD12_	SD11_	SD10_	SD9_4	SD8	SD7	SD6_4	SD5	SD4	SD3_4	SD2_4	SD1_4	SD0_
N		4	4	4	4		_4	_4		_4	_4				4

**Table 9 Shunt Voltage Register at PGA = /2**

At PGA = /2, full-scale range =  $\pm 80$  mV (decimal = 8000). For  $V_{SHUNT} = +80$  mV, Value = 1F40h; For  $V_{SHUNT} = -80$  mV, Value = E0C0h; and LSB = 10  $\mu$ V.

15	14	13	12	11	10	9	8	7	6	5	4	3	2	1	0
SIG	SIG	SIGN	SD12_	SD11_	SD10_	SD9_2	SD8	SD7	SD6_2	SD5	SD4	SD3_2	SD2_2	SD1_2	SD0_
N	N		2	2	2		_2	_2		_2	_2				2

**Table 10 Shunt Voltage Register at PGA = /1**

At PGA = /1, full-scale range =  $\pm 40$  mV (decimal = 4000). For  $V_{SHUNT} = +40$  mV, Value = 0FA0h; For  $V_{SHUNT} = -40$  mV, Value = F060h; and LSB = 10  $\mu$ V.

15	14	13	12	11	10	9	8	7	6	5	4	3	2	1	0
SIGN	SIGN	SIGN	SIGN	SD11_1	SD10_1	SD9_1	SD8_1	SD7_1	SD6_1	SD5_1	SD4_1	SD3_1	SD2_1	SD1_1	SD0_1

**Table 11 Shunt Voltage Register Format <sup>(1)</sup>**

$V_{SHUNT}$ Reading (mV)	Decimal Value	PGA = /8 (D15:D0)	PGA = /4 (D15:D0)	PGA = /2 (D15:D0)	PGA = /1 (D15:D0)
320.02	32002	0111 1101 0000 0000	0011 1110 1000 0000	0001 1111 0100 0000	0000 1111 1010 0000
320.01	32001	0111 1101 0000 0000	0011 1110 1000 0000	0001 1111 0100 0000	0000 1111 1010 0000
320.00	32000	0111 1101 0000 0000	0011 1110 1000 0000	0001 1111 0100 0000	0000 1111 1010 0000
319.99	31999	0111 1100 1111 1111	0011 1110 1000 0000	0001 1111 0100 0000	0000 1111 1010 0000
319.98	31998	0111 1100 1111 1110	0011 1110 1000 0000	0001 1111 0100 0000	0000 1111 1010 0000
⋮	⋮	⋮	⋮	⋮	⋮
160.02	16002	0011 1110 1000 0010	0011 1110 1000 0000	0001 1111 0100 0000	0000 1111 1010 0000
160.01	16001	0011 1110 1000 0001	0011 1110 1000 0000	0001 1111 0100 0000	0000 1111 1010 0000
160.00	16000	0011 1110 1000 0000	0011 1110 1000 0000	0001 1111 0100 0000	0000 1111 1010 0000
159.99	15999	0011 1110 0111 1111	0011 1110 0111 1111	0001 1111 0100 0000	0000 1111 1010 0000
159.98	15998	0011 1110 0111 1110	0011 1110 0111 1110	0001 1111 0100 0000	0000 1111 1010 0000
⋮	⋮	⋮	⋮	⋮	⋮
80.02	8002	0001 1111 0100 0010	0001 1111 0100 0010	0001 1111 0100 0000	0000 1111 1010 0000
80.01	8001	0001 1111 0100 0001	0001 1111 0100 0001	0001 1111 0100 0000	0000 1111 1010 0000
80.00	8000	0001 1111 0100 0000	0001 1111 0100 0000	0001 1111 0100 0000	0000 1111 1010 0000
79.99	7999	0001 1111 0011 1111	0001 1111 0011 1111	0001 1111 0011 1111	0000 1111 1010 0000
79.98	7998	0001 1111 0011 1110	0001 1111 0011 1110	0001 1111 0011 1110	0000 1111 1010 0000
⋮	⋮	⋮	⋮	⋮	⋮
40.02	4002	0000 1111 1010 0010	0000 1111 1010 0010	0000 1111 1010 0010	0000 1111 1010 0000
40.01	4001	0000 1111 1010 0001	0000 1111 1010 0001	0000 1111 1010 0001	0000 1111 1010 0000
40.00	4000	0000 1111 1010 0000	0000 1111 1010 0000	0000 1111 1010 0000	0000 1111 1010 0000
39.99	3999	0000 1111 1001 1111	0000 1111 1001 1111	0000 1111 1001 1111	0000 1111 1001 1111
39.98	3998	0000 1111 1001 1110	0000 1111 1001 1110	0000 1111 1001 1110	0000 1111 1001 1110
⋮	⋮	⋮	⋮	⋮	⋮
0.02	2	0000 0000 0000 0010	0000 0000 0000 0010	0000 0000 0000 0010	0000 0000 0000 0010
0.01	1	0000 0000 0000 0001	0000 0000 0000 0001	0000 0000 0000 0001	0000 0000 0000 0001
0	0	0000 0000 0000 0000	0000 0000 0000 0000	0000 0000 0000 0000	0000 0000 0000 0000
-0.01	-1	1111 1111 1111 1111	1111 1111 1111 1111	1111 1111 1111 1111	1111 1111 1111 1111
-0.02	-2	1111 1111 1111 1110	1111 1111 1111 1110	1111 1111 1111 1110	1111 1111 1111 1110
⋮	⋮	⋮	⋮	⋮	⋮

V <sub>SHUNT</sub> Reading (mV)	Decimal Value	PGA = /8 (D15:D0)	PGA = /4 (D15:D0)	PGA = /2 (D15:D0)	PGA = /1 (D15:D0)
-39.98	-3998	1111 0000 0110 0010	1111 0000 0110 0010	1111 0000 0110 0010	1111 0000 0110 0010
-39.99	-3999	1111 0000 0110 0001	1111 0000 0110 0001	1111 0000 0110 0001	1111 0000 0110 0001
-40.00	-4000	1111 0000 0110 0000	1111 0000 0110 0000	1111 0000 0110 0000	1111 0000 0110 0000
-40.01	-4001	1111 0000 0101 1111	1111 0000 0101 1111	1111 0000 0101 1111	1111 0000 0110 0000
-40.02	-4002	1111 0000 0101 1110	1111 0000 0101 1110	1111 0000 0101 1110	1111 0000 0110 0000
⋮	⋮	⋮	⋮	⋮	⋮
-79.98	-7998	1110 0000 1100 0010	1110 0000 1100 0010	1110 0000 1100 0010	1111 0000 0110 0000
-79.99	-7999	1110 0000 1100 0001	1110 0000 1100 0001	1110 0000 1100 0001	1111 0000 0110 0000
-80.00	-8000	1110 0000 1100 0000	1110 0000 1100 0000	1110 0000 1100 0000	1111 0000 0110 0000
-80.01	-8001	1110 0000 1011 1111	1110 0000 1011 1111	1110 0000 1100 0000	1111 0000 0110 0000
-80.02	-8002	1110 0000 1011 1110	1110 0000 1011 1110	1110 0000 1100 0000	1111 0000 0110 0000
⋮	⋮	⋮	⋮	⋮	⋮
-159.98	-15998	1100 0001 1000 0010	1100 0001 1000 0010	1110 0000 1100 0000	1111 0000 0110 0000
-159.99	-15999	1100 0001 1000 0001	1100 0001 1000 0001	1110 0000 1100 0000	1111 0000 0110 0000
-160.00	-16000	1100 0001 1000 0000	1100 0001 1000 0000	1110 0000 1100 0000	1111 0000 0110 0000
-160.01	-16001	1100 0001 0111 1111	1100 0001 1000 0000	1110 0000 1100 0000	1111 0000 0110 0000
-160.02	-16002	1100 0001 0111 1110	1100 0001 1000 0000	1110 0000 1100 0000	1111 0000 0110 0000
⋮	⋮	⋮	⋮	⋮	⋮
-319.98	-31998	1000 0011 0000 0010	1100 0001 1000 0000	1110 0000 1100 0000	1111 0000 0110 0000
-319.99	-31999	1000 0011 0000 0001	1100 0001 1000 0000	1110 0000 1100 0000	1111 0000 0110 0000
-320.00	-32000	1000 0011 0000 0000	1100 0001 1000 0000	1110 0000 1100 0000	1111 0000 0110 0000
-320.01	-32001	1000 0011 0000 0000	1100 0001 1000 0000	1110 0000 1100 0000	1111 0000 0110 0000
-320.02	-32002	1000 0011 0000 0000	1100 0001 1000 0000	1110 0000 1100 0000	1111 0000 0110 0000

(1) Out-of-range values are shown in gray shading.

### Bus Voltage Register (address = 02h)

The Bus Voltage register stores the most recent bus voltage reading, VBUS.

**Table 12 Bus Voltage Register (BRNG = 1)**

At full-scale range = 32 V (decimal = 8000, hex = 1F40), and LSB = 4 mV.

15	14	13	12	11	10	9	8	7	6	5	4	3	2	1	0
BD12	BD11	BD10	BD9	BD8	BD7	BD6	BD5	BD4	BD3	BD2	BD1	BD0	—	CNVR	OVF

**Table 13 Bus Voltage Register (BRNG = 0)**

At full-scale range = 16 V (decimal = 4000, hex = 0FA0), and LSB = 4 mV.

15	14	13	12	11	10	9	8	7	6	5	4	3	2	1	0
0	BD11	BD10	BD9	BD8	BD7	BD6	BD5	BD4	BD3	BD2	BD1	BD0	—	CNVR	OVF

**CNVR: Conversion Ready**

Bit 1 Although the data from the last conversion can be read at any time, the TPA620 Conversion Ready bit (CNVR) indicates when data from a conversion is available in the data output registers. The CNVR bit is set after all conversions, averaging, and multiplications are

complete. CNVR will clear under the following conditions:

- 1.) Writing a new mode into the Operating Mode bits in the Configuration Register (except for Power-Down or Disable)
- 2.) Reading the Bus Voltage Register

**OVF: Math Overflow Flag**

Bit 0 The Math Overflow Flag (OVF) is set when the Power or Current calculations are out of range. It indicates that current and power data may be meaningless.

**Power Register (address = 03h) [reset = 00h]**

Full-scale range and LSB are set by the Calibration register. The Power register records power in watts by multiplying the values of the current with the value of the bus voltage.

*Table 14 Power Register*

15	14	13	12	11	10	9	8	7	6	5	4	3	2	1	0
PD15	PD14	PD13	PD12	PD11	PD10	PD9	PD8	PD7	PD6	PD5	PD4	PD3	PD2	PD1	PD0
R-0	R-0	R-0	R-0	R-0	R-0	R-0	R-0	R-0	R-0	R-0	R-0	R-0	R-0	R-0	R-0

LEGEND: R/W = Read/Write; R = Read only; -n = value after reset

**Current Register (address = 04h) [reset = 00h]**

Full-scale range and LSB depend on the value entered in the Calibration register. Negative values are stored in 2's complement format.

*Table 15 Current Register*

15	14	13	12	11	10	9	8	7	6	5	4	3	2	1	0
CSIGN	CD14	CD13	CD12	CD11	CD10	CD9	CD8	CD7	CD6	CD5	CD4	CD3	CD2	CD1	CD0
R-0	R-0	R-0	R-0	R-0	R-0	R-0	R-0	R-0	R-0	R-0	R-0	R-0	R-0	R-0	R-0

LEGEND: R/W = Read/Write; R = Read only; -n = value after reset

**Calibration Register**

The value of the Current register is calculated by multiplying the value in the Shunt Voltage register with the value in the Calibration register.

**Calibration Register (address = 05h) [reset = 00h]**

Current and power calibration are set by bits FS15 to FS1 of the Calibration register. Note that bit FS0 is not used in the calculation. This register sets the current that corresponds to a full-scale drop across the shunt. Full-scale range and the LSB of the current and power measurement depend on the value entered in this register. This register is suitable for use in overall system calibration. Note that the 0 POR values are all default.

*Table 16 Calibration Register<sup>(1)</sup>*

15	14	13	12	11	10	9	8	7	6	5	4	3	2	1	0
FS15	FS14	FS13	FS12	FS11	FS10	FS9	FS8	FS7	FS6	FS5	FS4	FS3	FS2	FS1	FS0
R/W-0	R/W-0	R/W-0	R/W-0	R/W-0	R/W-0	R/W-0	R/W-0	R/W-0	R/W-0	R/W-0	R/W-0	R/W-0	R/W-0	R/W-0	R/W-0
						0	0	0	0	0	0				

LEGEND: R/W = Read/Write; R = Read only; -n = value after reset

**Note1:** FS0 is a void bit and will always be 0. It is not possible to write a 1 to FS0. CALIBRATION is the value stored in FS15:FS1.



Package Information

MSOP10

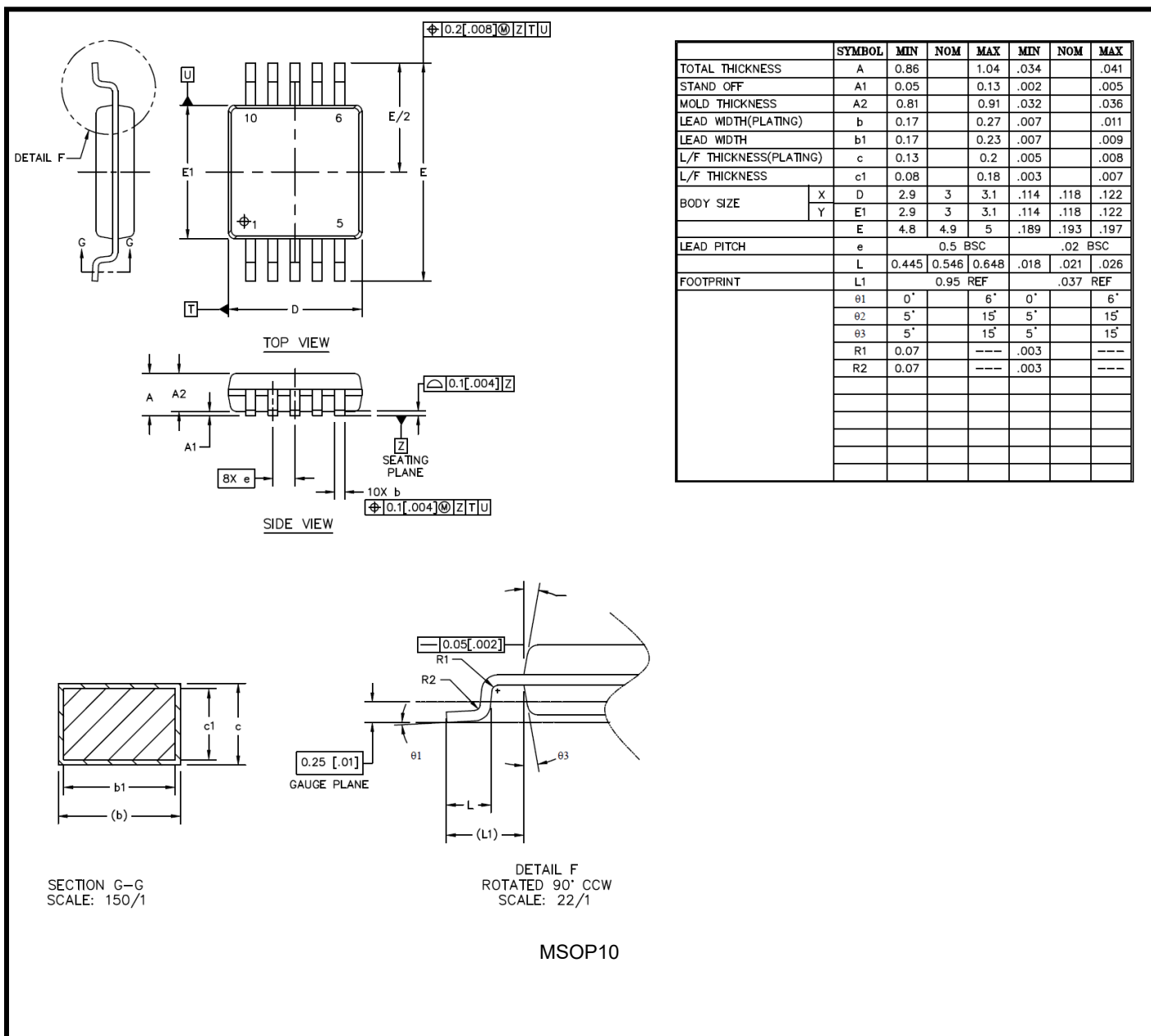

MSOP10

3PEAK and the 3PEAK logo are registered trademarks of 3PEAK INCORPORATED. All other trademarks are the property of their respective owners.

单击下面可查看定价，库存，交付和生命周期等信息

[>>3PEAK\(思瑞浦\)](#)