

36-V Input, 2-A Synchronous Step-Down Voltage Regulator

Features

- Wide Supply Voltage: 4.5 V to 36 V
- Internal Power FET: 180 mΩ and 90 mΩ
- 0.6-V Reference Voltage with 2% Accuracy
- High-Efficiency Synchronous-Mode Operation
- Fixed Switching Frequency
 - 500 kHz (TPP362080/2)
 - 2.2 MHz (TPP362081/3)
- Low 2-μA Shutdown, 70-μA Quiescent Current
- Internal Light Load Power-Save Mode for High Efficiency at Light Load (TPP362080/1)
- Forced-PWM Mode for Low-Output Ripple (TPP362082/3)
- Internal 2-ms Soft-Start Timer
- Internal Loop Compensation
- Over-Current Protection with Hiccup Mode
- Output over Voltage Protection
- Thermal Shutdown
- Small Outline Package TSOT23-6
- -40°C to 125°C Operation Ambient Temperature Range

Applications

- 12-V, 24-V Distributed Power Supply
- Industrial Applications
- General Purpose

Description

The TPP36208x series is a simple, easy-to-use, 2-A output, synchronous, step-down, and switch-mode converter with internal power MOSFETs.

The TPP36208x series integrates low- $R_{DS(ON)}$ power transistors in the TSOT23-6 package with internal soft-start, compensation, and protection features. The TPP36208x offers a very compact solution to achieve a 2-A continuous output current over a wide input supply range, with excellent load and line regulation.

The TPP36208x series has different versions of switching frequencies at 500-kHz and 2.2-MHz, and also supports light load PSM to save quiescent current and forced-PWM mode to maintain the fixed switching frequency.

The device is available in the 6-pin TSOT23-6 package with the support of a wide operation ambient temperature range from -40 °C to 125 °C.

Typical Application Circuit

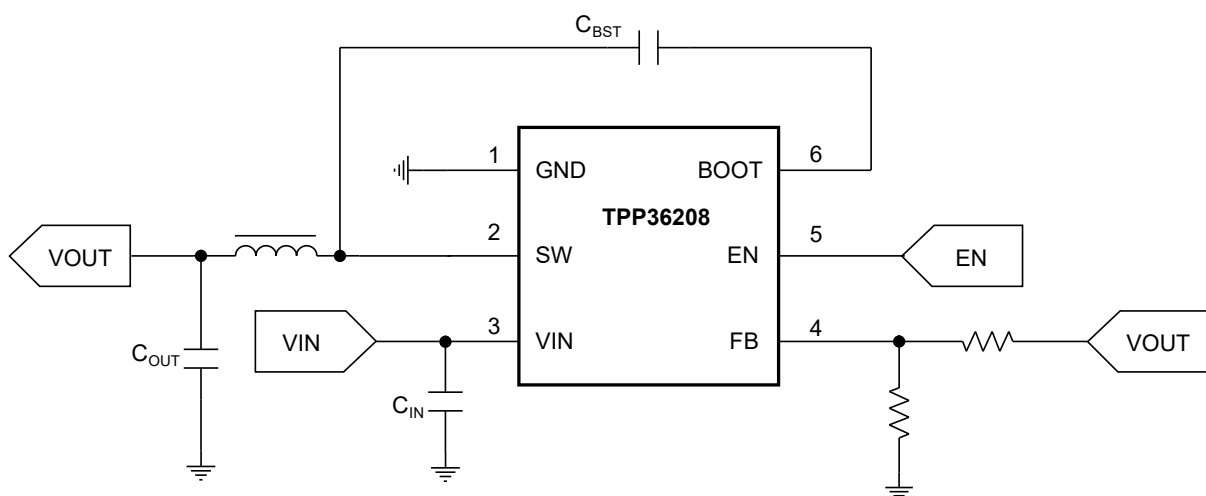

36-V Input, 2-A Synchronous Step-Down Voltage Regulator**Table of Contents**

Features	1
Applications	1
Description	1
Typical Application Circuit	1
Revision History	3
Pin Configuration and Functions	4
Specifications	5
Absolute Maximum Ratings ⁽¹⁾	5
ESD, Electrostatic Discharge Protection.....	5
Recommended Operating Conditions.....	6
Thermal Information.....	6
Electrical Characteristics.....	7
Typical Performance Characteristics.....	8
Detailed Description	12
Overview.....	12
Functional Block Diagram.....	12
Feature Description.....	13
Application and Implementation	14
Application Information	14
Typical Application.....	14
Layout	16
Layout Guideline.....	16
Layout Recommendations.....	16
Tape and Reel Information	17
Package Outline Dimensions	18
TSOT23-6.....	18
Order Information	19

36-V Input, 2-A Synchronous Step-Down Voltage Regulator**Revision History**

Date	Revision	Notes
2022-03-15	Rev A.0	Initial release.
2022-07-11	Rev A.1	Minor correction. Updated description of EN pin function to internally weak pulled up.
2022-07-31	Rev A.2	Updated order information, automotive grade devices, electrical table rising/ falling timing and block diagrams.
2022-12-28	Rev A.3	Updated information in Typical Performance Characteristics.

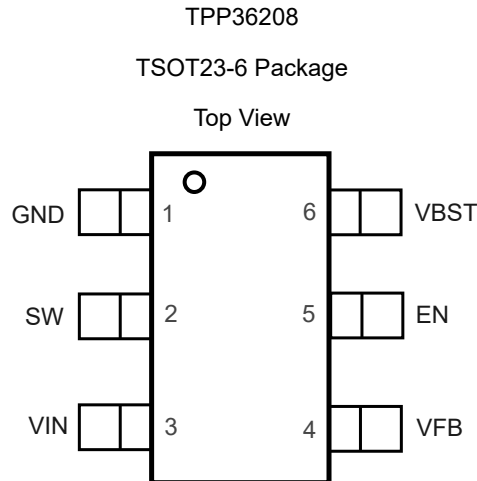
36-V Input, 2-A Synchronous Step-Down Voltage Regulator
Pin Configuration and Functions

Table 1. Pin Functions: TPP36208x

Pin	Name	I/O	Description
1	GND	G	Ground pin. Power and controller circuit ground. Use star connection to GND pin with good contact.
2	SW	O	Switching node pin. Voltage switching between high-side FET and low-side FET.
3	VIN	P	Supply input pin. Connect decoupling $2 \times 10\text{-}\mu\text{F}$ and $1 \times 0.1\text{-}\mu\text{F}$ capacitors between VIN and GND pins.
4	VFB	I	Voltage feedback pin. Connect to output voltage with a feedback resistor divider.
5	EN	I	Enable input. Active high. Internally weak pulled up.
6	VBST	O	High-side MOSFET gate supply pin. Connect $0.1\text{-}\mu\text{F}$ between VBST and SW pins.

36-V Input, 2-A Synchronous Step-Down Voltage Regulator
Specifications
Absolute Maximum Ratings ⁽¹⁾

Parameter		Min	Max	Unit
V _{IN}	Supply Voltage	-0.3	42	V
SW	Switching Node Voltage	-0.3	V _{IN} + 0.3	V
	Switching Node Voltage (50 ns)	-3	42	V
	Switching Node Voltage (20 ns)	-5	42	V
VBST-SW	Bootstrap Voltage	-0.3	6	V
FB	Feedback Voltage	-0.3	6	V
EN	Enable Input	-0.3	42	V
T _J	Maximum Junction Temperature	-40	150	°C
T _A	Operating Temperature Range	-40	125	°C
T _{STG}	Storage Temperature Range	-65	150	°C
T _L	Lead Temperature (Soldering 10 sec)		260	°C

- (1) Stresses beyond those listed under Absolute Maximum Ratings may cause permanent damage to the device. Exposure to any Absolute Maximum Rating condition for extended periods may affect device reliability and lifetime.
- (2) The inputs are protected by ESD protection diodes to each power supply. If the input extends more than 300 mV beyond the power supply, the input current should be limited to less than 10 mA.
- (3) A heat sink may be required to keep the junction temperature below the absolute maximum. This depends on the power supply voltage and how many amplifiers are shorted. Thermal resistance varies with the amount of PC board metal connected to the package. The specified values are for short traces connected to the leads.

ESD, Electrostatic Discharge Protection

Parameter		Condition	Minimum Level	Unit
HBM	Human Body Model ESD	ANSI/ESDA/JEDEC JS-001 ⁽¹⁾	2	kV
CDM	Charged Device Model ESD	ANSI/ESDA/JEDEC JS-002 ⁽²⁾	1.5	kV

- (1) JEDEC document JEP155 states that 500-V HBM allows safe manufacturing with a standard ESD control process.
- (2) JEDEC document JEP157 states that 250-V CDM allows safe manufacturing with a standard ESD control process.

36-V Input, 2-A Synchronous Step-Down Voltage Regulator**Recommended Operating Conditions**

Parameter		Min	Typ	Max	Unit
VIN	Supply Input Voltage Range	4.5		36	V
EN	EN Input Voltage Range	0		5.5	V
FB	FB Input Voltage Range	0		5.5	V
BOOT – SW	BOOT Voltage Range	0		5.5	V
SW	FB Input Voltage Range	0		VIN	V
T _J	Operating Junction Temperature	–40		150	°C

Thermal Information

Package Type	θ_{JA}	θ_{JC}	Unit
TSOT23-6	100	67	°C/W

36-V Input, 2-A Synchronous Step-Down Voltage Regulator
Electrical Characteristics

All test condition is at $V_{IN} = 12\text{ V}$, $T_A = -40^\circ\text{C}$ to $+125^\circ\text{C}$, unless otherwise noted.

Parameter	Conditions	Min	Typ	Max	Unit		
Power Supply							
V_{IN}	Supply Voltage Range	4.5		36	V		
I_Q	Operating Supply Current	Non-switching, $EN = 5\text{ V}$, $V_{FB} = 1\text{ V}$		70	μA		
I_{QSD}	Shut Down Supply Current	$EN = \text{GND}$		2	μA		
V_{UVLO_rising}	UVLO Rising Threshold	3.9	4.3	4.5	V		
$V_{UVLO_falling}$	UVLO Falling Threshold	3.7	3.9	4.1	V		
Enable							
V_{ENH}	EN Input Rising Threshold		1.28	1.35	V		
V_{ENL}	EN Input Falling Threshold	1	1.17		V		
Feedback and Power Stage							
V_{FB}	V_{FB} Feedback Voltage	588	600	612	mV		
$R_{ds(on)_HSD}$	High-side FET On-Resistance	$I_{SW} = 1\text{ A}$		180	$\text{m}\Omega$		
$R_{ds(on)_LSD}$	Low-side FET On-Resistance	$I_{SW} = 1\text{ A}$		90	$\text{m}\Omega$		
f_{SW}	Switching Frequency	TPP362080/2		390	500	590	kHz
		TPP362081/3			2.2		MHz
t_{SS}	Soft-Start Time		2		ms		
I_{skip}	Pulse-Skip Mode Peak Inductor Current Threshold	$V_{IN} = 12\text{ V}$, $V_{OUT} = 5\text{ V}$, $L = 15\text{ }\mu\text{H}$		300		mA	
Current Limit							
I_{Limit_HS}	High-side Current Limit	Inductor peak current		2.5	3.2	3.9	A
I_{Limit_LS}	Low-side Current Limit	Inductor valley current			2.5		A
$I_{Limit_LS_neg}$	Negative Low-side Current Limit		0.9			A	
Diagnostics and Protection							
$V_{FB_UVP_rising}$	FB Hiccup Protection Rising Ratio		33		%		
$V_{FB_UVP_falling}$	FB Hiccup Protection Falling Ratio		40		%		
$V_{FB_OVP_rising}$	FB Over-Voltage Protection Rising Ratio		108		%		
$V_{FB_OVP_falling}$	FB Over-Voltage Protection Falling Ratio		107		%		
t_{HIC_wait}	Hiccup Protection Wait Time		128		Cycles		
$t_{HIC_restart}$	Hiccup Protection Restart Time		60		ms		
Thermal Shutdown							
T_{SD}	Thermal Shut Down Temperature		160		$^\circ\text{C}$		
T_{SD_hys}	Thermal Hysteresis		10		$^\circ\text{C}$		

36-V Input, 2-A Synchronous Step-Down Voltage Regulator

Typical Performance Characteristics

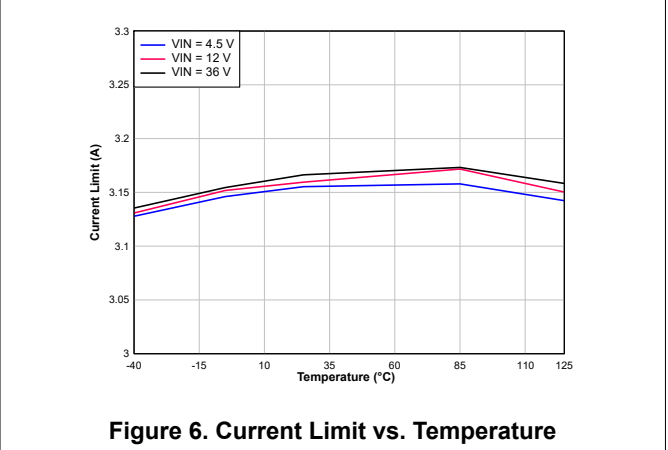
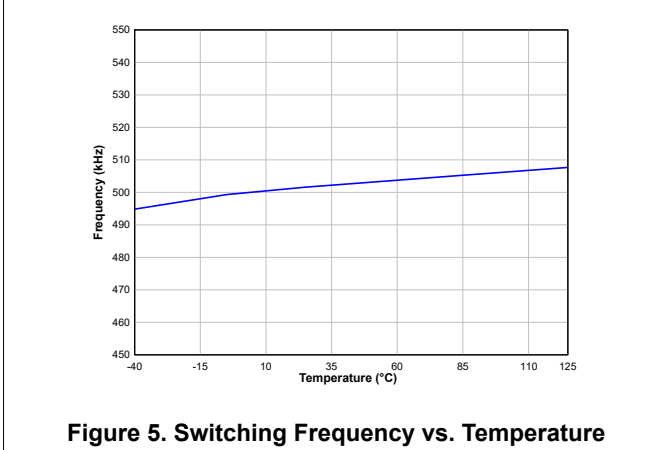
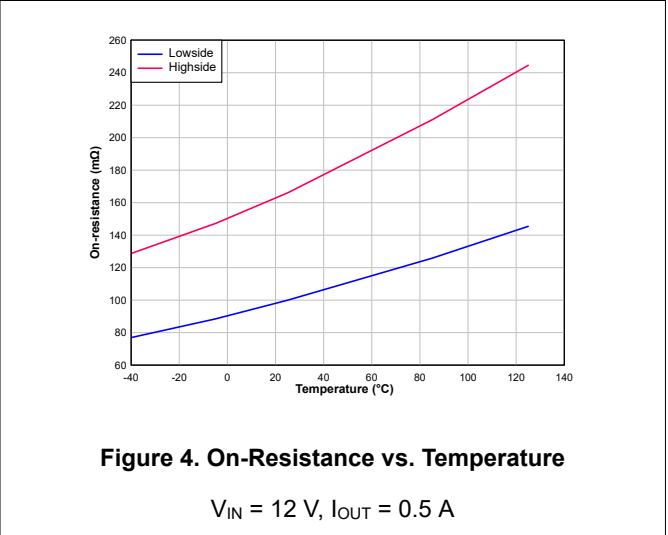
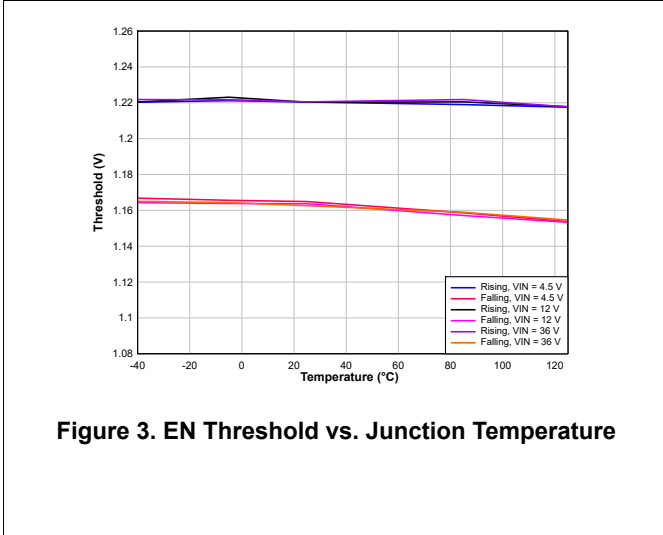
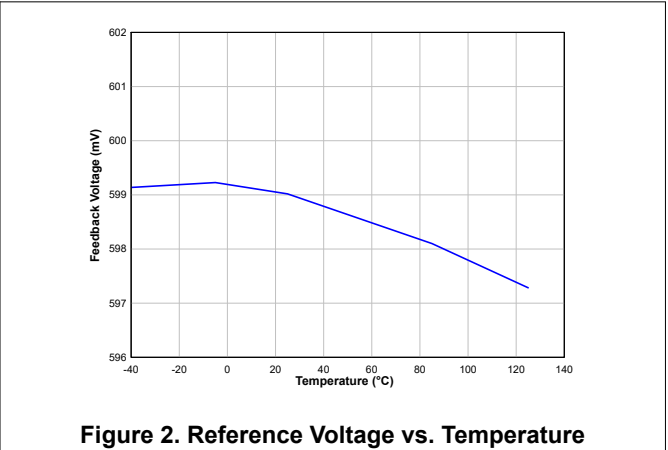
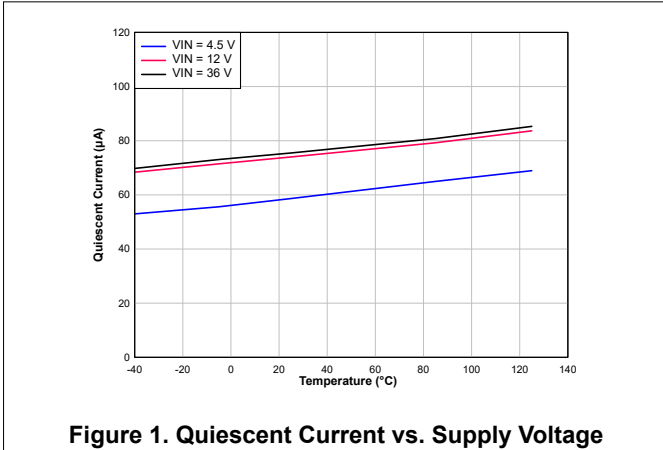

36-V Input, 2-A Synchronous Step-Down Voltage Regulator

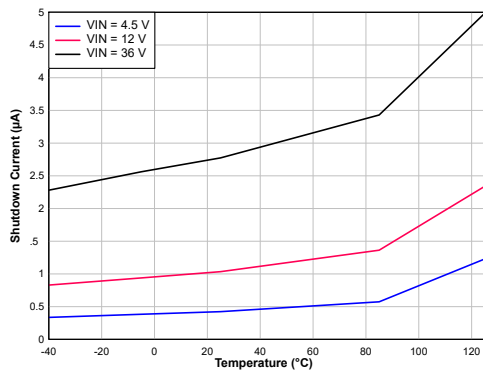

Figure 7. Shutdown Current vs. Junction Temperature

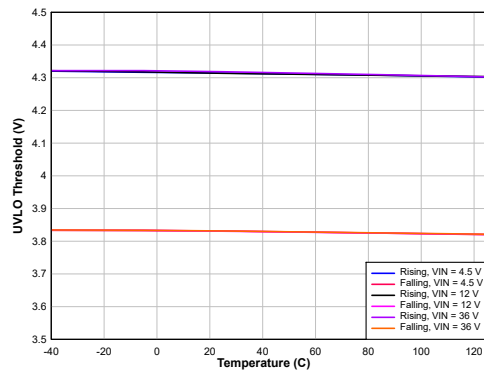

Figure 8. UVLO Threshold vs. Temperature

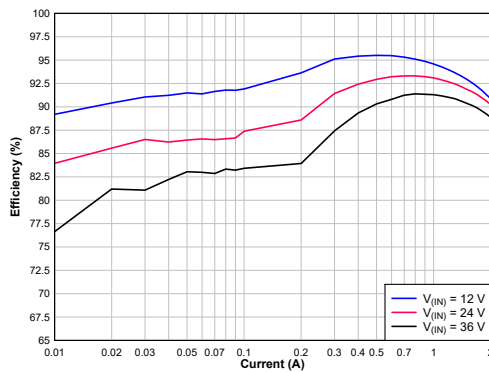

Figure 9. Efficiency vs. Output Current

$V_{OUT} = 5\text{ V}$, $L = 2.2\ \mu\text{H}$, 500kHz, TPP362080 with Pulse Skip Mode

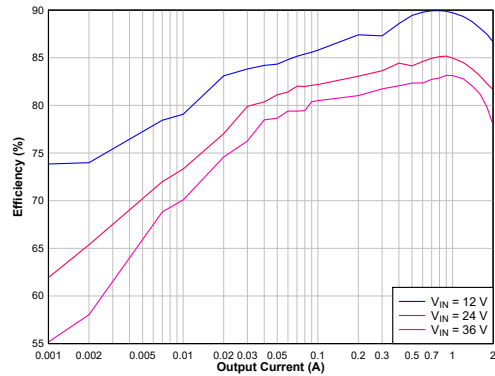

Figure 10. Efficiency vs. Output Current

$V_{OUT} = 5\text{ V}$, $L = 2.2\ \mu\text{H}$, 2.2MHz, TPP362081 with Pulse Skip Mode

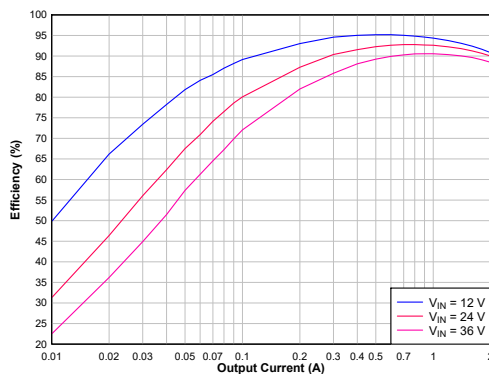

Figure 11. Efficiency vs. Output Current

$V_{OUT} = 5\text{ V}$, $L = 2.2\ \mu\text{H}$, 500kHz, TPP362082 with Forced-PWM Mode

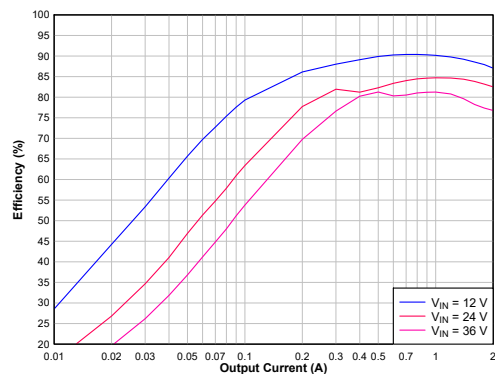
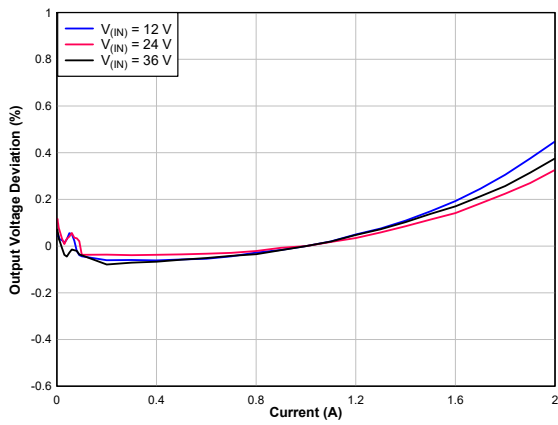
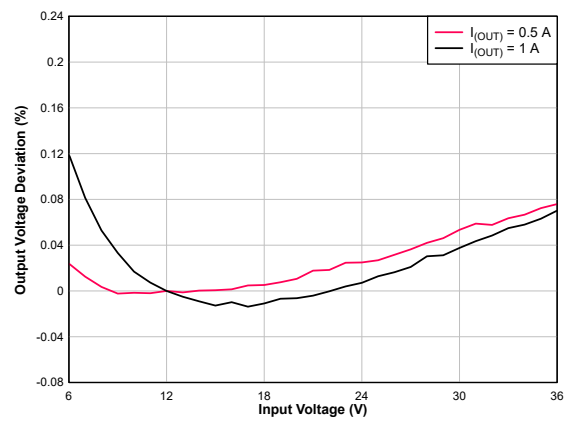
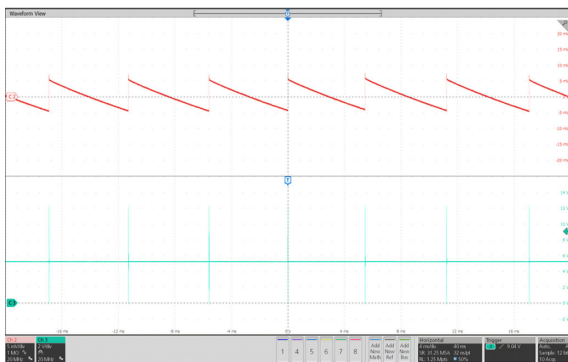
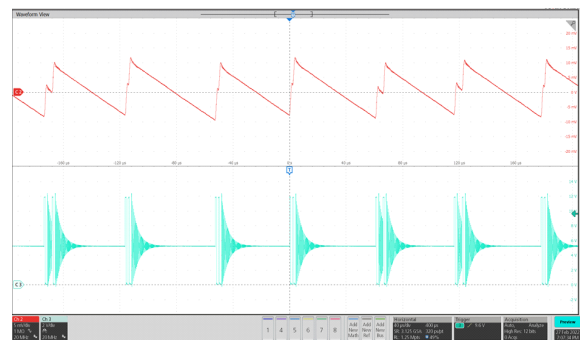

Figure 12. Efficiency vs. Output Current

$V_{OUT} = 5\text{ V}$, $L = 2.2\ \mu\text{H}$, 2.2MHz, TPP362083 with Forced-PWM Mode

36-V Input, 2-A Synchronous Step-Down Voltage Regulator

Figure 13. Load Regulation
 $V_{OUT} = 5\text{ V}$

Figure 14. Line Regulation
 $V_{OUT} = 5\text{ V}$

Figure 15. Pulse Skip Mode Output Voltage Ripple

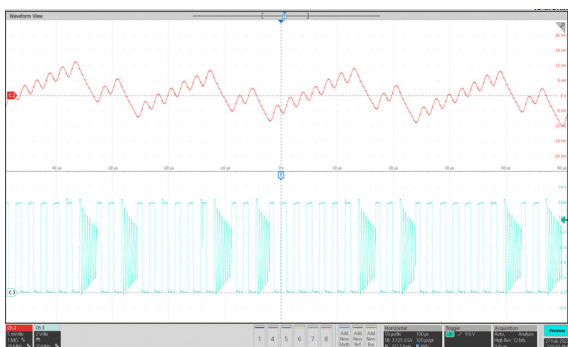
 CH2: SW, CH3: V_{OUT} Ripple

 $V_{IN} = 12\text{ V}, V_{OUT} = 5\text{ V}, I_L = 0\text{ A}$

Figure 16. Pulse Skip Mode Output Voltage Ripple

 CH2: V_{OUT} Ripple, CH3: SW

 $V_{IN} = 12\text{ V}, V_{OUT} = 5\text{ V}, I_L = 10\text{ mA}$

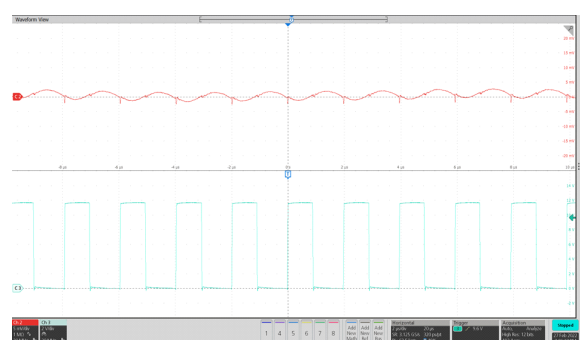
Figure 17. Pulse Skip Mode Output Voltage Ripple

 CH2: V_{OUT} , CH3: SW

 $V_{IN} = 12\text{ V}, V_{OUT} = 5\text{ V}, I_L = 0.1\text{ A}$

Figure 18. Output Voltage Ripple

 CH2: V_{OUT} , CH3: SW

 $V_{IN} = 12\text{ V}, V_{OUT} = 5\text{ V}, I_L = 1\text{ A}$

36-V Input, 2-A Synchronous Step-Down Voltage Regulator

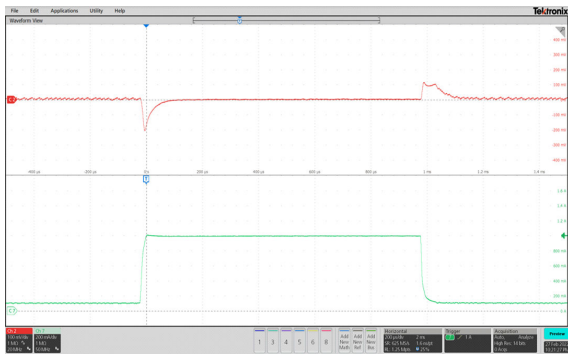

Figure 19. Load Transient

CH2: V_{OUT} , CH4: Load Current

$V_{IN} = 12\text{ V}$, $V_{OUT} = 5\text{ V}$, $I_L = 0.1\text{ A}$ to 1 A

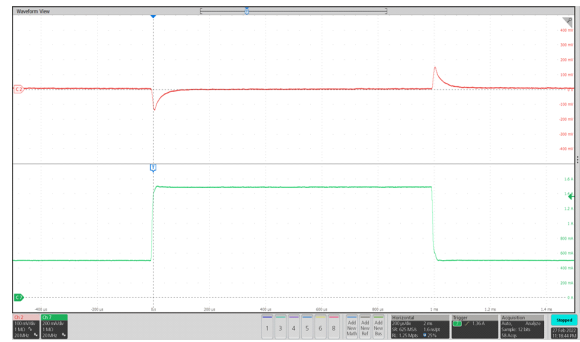

Figure 20. Load Transient

CH2: V_{OUT} , CH4: Load Current

$V_{IN} = 12\text{ V}$, $V_{OUT} = 5\text{ V}$, $I_L = 0.5\text{ A}$ to 1.5 A

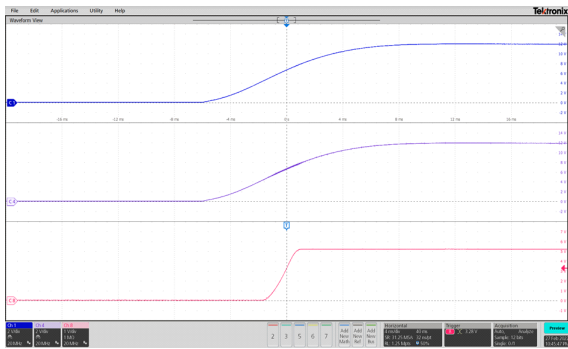

Figure 21. Start Up by VIN

CH1: V_{IN} , CH4: EN, CH8: V_{OUT}

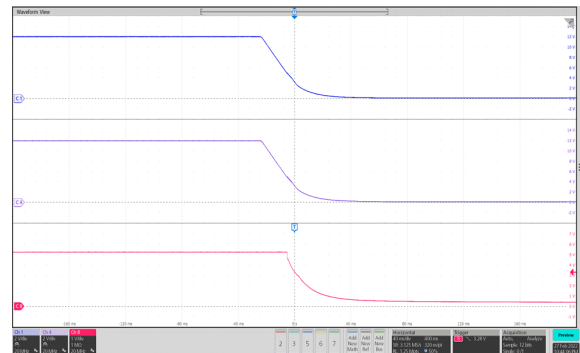

Figure 22. Power-Down by VIN

CH1: V_{IN} , CH4: EN, CH8: V_{OUT}

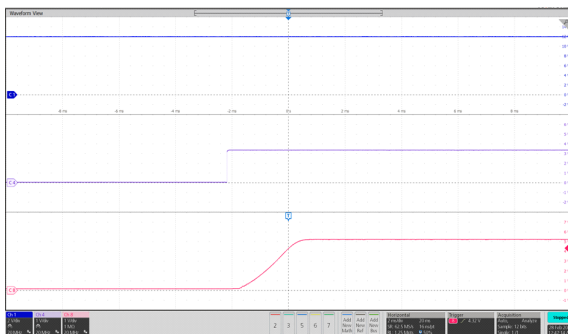

Figure 23. Start Up by EN

CH1: V_{IN} , CH4: EN, CH8: V_{OUT}

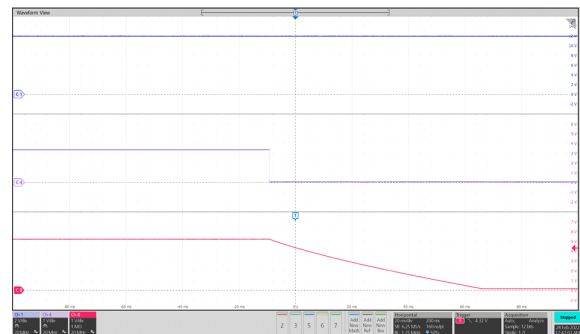

Figure 24. Power-Down by EN

CH1: V_{IN} , CH4: EN, CH8: V_{OUT}

36-V Input, 2-A Synchronous Step-Down Voltage Regulator

Detailed Description

Overview

The TPP36208x is a 2-A synchronous step-down converter. The current mode control topology provides a fast transient response and supports low ESR output capacitors, such as specialty polymer capacitors and multi-layer ceramic capacitors, without extra compensation circuitry.

Device	Frequency	Low Output Current Mode
TPP362080-T6TR	500 kHz	Pulse-Skip Mode
TPP362081-T6TR	2.2 MHz	Pulse-Skip Mode
TPP362082-T6TR	500 kHz	Forced-PWM Mode
TPP362083-T6TR	2.2 MHz	Forced-PWM Mode

Functional Block Diagram

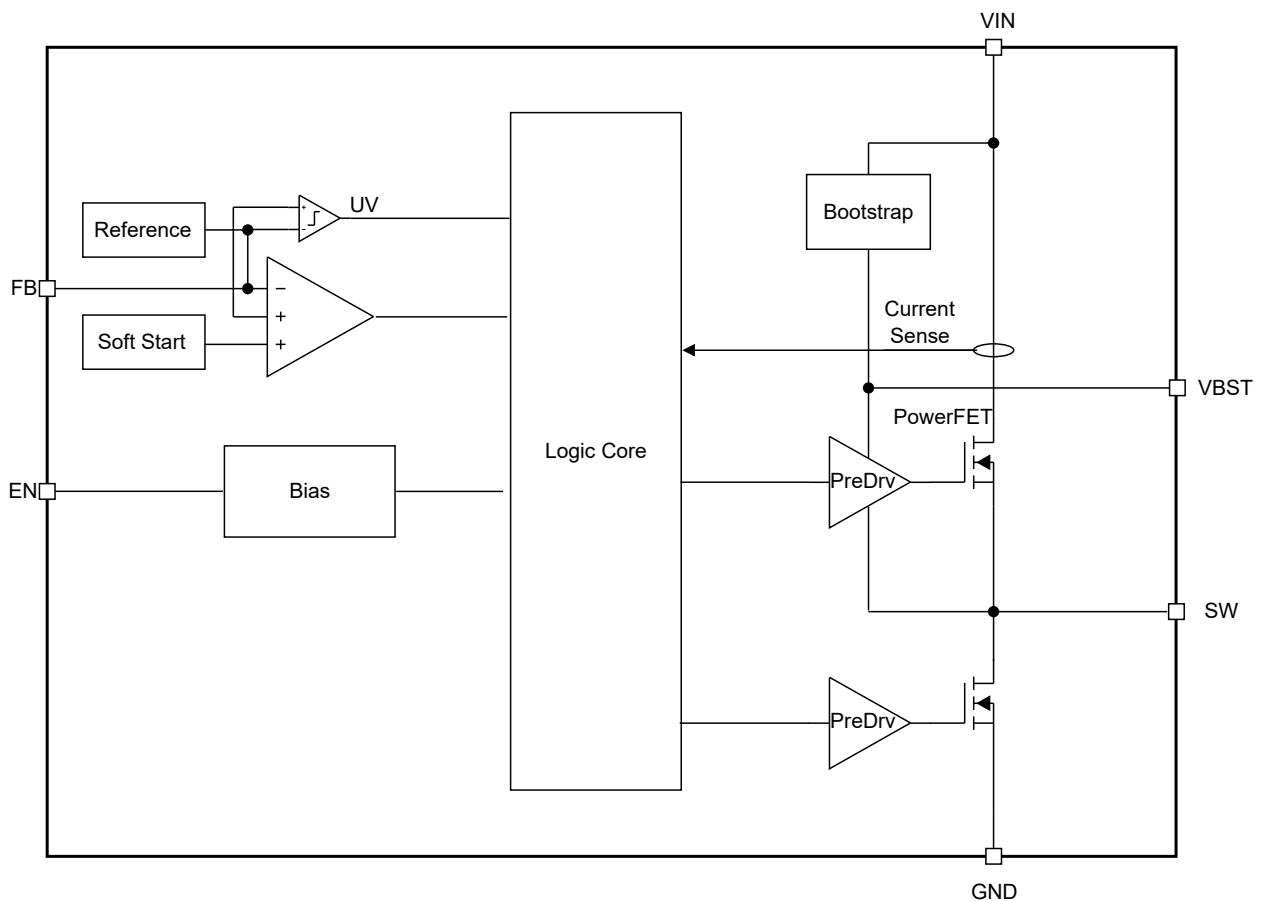

Figure 25. Functional Block Diagram

36-V Input, 2-A Synchronous Step-Down Voltage Regulator

Feature Description

Current Mode Control

The TPP36208x uses the current mode control topology. The current mode topology supports fixed frequency operation thus optimizing ripple performance. With integrated low $R_{ds(on)}$, the device can achieve high efficiency in a small physical footprint.

Switching Frequency

TPP36208x supports both 500-kHz(TPP362080/TPP362082) and 2.2-MHz switching frequency(TPP362081/TPP362083). 500-kHz has better efficiency due to less switching loss, while 2.2-MHz supports high frequency inductor with small form factor. 3PEAK recommends to evaluate thermal performance in 2.2-MHz scenarios especially at high temperature conditions.

Pulse-Skip Mode

To improve light-load efficiency, the TPP362080/1 will automatically enter improved light-load mode when the inductor ripple valley current reaches zero. The controller keeps the on-time of the high-side switch unchanged. With a light load, the decay of voltage takes a longer time and lowers the switching frequency accordingly.

Forced-PWM Mode

The TPP362082/3 has forced-PWM mode to support low-noise applications. When the inductor ripple valley current reaches zero, the device will automatically enter the forced-PWM mode with a fixed switching frequency. In this mode, the negative current limit of low-side FET is enabled.

Soft-Start with Pre-Biased Capability

Once EN becomes high, the device ramps up its internal reference voltage with a fixed 2-ms rise time. When the output capacitor is pre-charged, the soft-start ramp will only enable output switching after the internal reference ramps above the FB voltage.

Over Current Protection

The device has a cycle-by-cycle current limit. During the OFF state, once overcurrent is detected at ripple current valley by measuring the low-side FET current, the device keeps the low-side FET OFF until the current falls below the over-current protection (OCP) threshold. The device has negative current and can block reverse current when reverse inductor current is higher than threshold.

Output Undervoltage Hiccup Protection

When the device output voltage falls below the hiccup voltage threshold, the device turns into the hiccup mode by turning off the device and restarts after the hiccup timer (typically 60 ms) expires.

Undervoltage Lockout (UVLO) Protection

Once the input voltage falls below the UVLO threshold, the device is shut off. Once the device recovers above the UVLO threshold, the device returns to normal operation.

Over-Temperature Shutdown

Once the junction temperature rises above the internal over-temperature shutdown threshold, the device shuts off and recovers when the temperature falls below the threshold with hysteresis.

36-V Input, 2-A Synchronous Step-Down Voltage Regulator

Application and Implementation

Note

Information in the following application sections is not part of the 3PEAK's component specification and 3PEAK does not warrant its accuracy or completeness. 3PEAK's customers are responsible for determining suitability of components for their purposes. Customers should validate and test their design implementation to confirm system functionality.

Application Information

As an easy-to-use step-down voltage regulator, also known as a buck regulator, the TPP36208x usually covers a higher input voltage to the desired output voltage set by the VFB resistor divider. The maximum output current is 2 A. The below section depicts a simplified design flow of circuitry for the TPP36208x.

Typical Application

In most 12-V systems, lower voltage rail such as 5 V/3.3 V is a typical need for microcontrollers, I/Os, and other low voltage components. The below application lists the typical schematic for a 5-V buck regulator.

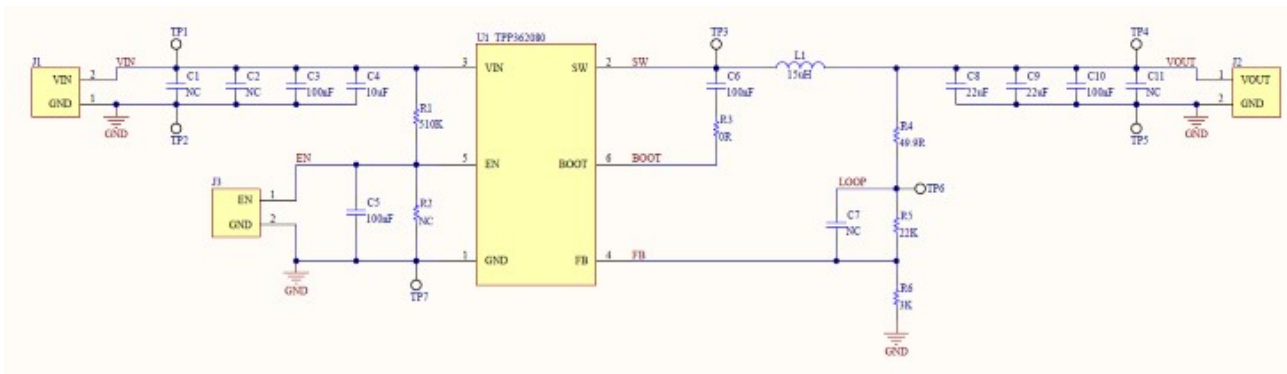

Figure 26. Typical Application Circuit

Component Selection

EVM: $F_{sw} = 500 \text{ kHz}$, MODE = Pulse-Skip, $I_{out} = 2 \text{ A}$, $t_{ss} = 2 \text{ ms}$, $V_{out} = 5 \text{ V}$						
Designator	Value	Quantity	Part No.	Package	Manufacturer	Description
U1	TPP362080	1	TPP362080-T6TR	SOT23-6	3PEAK	Buck Converter, 36 V, 2 A, 500 kHz, PFM
C1	NC	0				
C2	NC	0				
C3	100 nF	1	GGD21BR71H10 4KA02	0805	muRata	Capacitor, 100 nF, 50VDC, X7R, $\pm 15\%$
C4	10 μF	1	GCM32EC71H10 6MA03L	1210	muRata	Capacitor, 10 μF , 50VDC, X7S, $\pm 22\%$
R1	510 K	1	ARG03FTC5103	0603	Viking	Resistor, 510 K, $\pm 1\%$, 0.1 W
C5	NC	0				

36-V Input, 2-A Synchronous Step-Down Voltage Regulator

EVM: $F_{sw} = 500 \text{ kHz}$, MODE = Pulse-Skip, $I_{out} = 2 \text{ A}$, $t_{ss} = 2 \text{ ms}$, $V_{out} = 5 \text{ V}$						
Designator	Value	Quantity	Part No.	Package	Manufacturer	Description
R2	100 K	1	ARG03FTC1003	0603	Viking	Resistor, 100 K, $\pm 1\%$, 0.1 W
C6	100 nF	1	GRM188R71C104KA01D	0603	muRata	Capacitor, 100 nF, 16VDC, X7R, $\pm 15\%$
C7	NC	0				
R3	0 R	1	ERJ-3GEY0R00V	0603	Panasonic	Resistor, 0 Ω , 5%, 0.1 W
L1	15 μH	1	7447714150	10mm \times 5mm \times 10mm	Wurth Elektronik eiSos	Inductor, 15 μH , 3.5 A, 36ohm, $\pm 20\%$
C8	22 μF	1	GRM32ER71E226ME15L	1210	muRata	Capacitor, 22 μF , 25VDC, X7R, $\pm 15\%$
C9	22 μF	1	GRM32ER71E226ME15L	1210	muRata	Capacitor, 22 μF , 25VDC, X7R, $\pm 15\%$
C10	100 nF	1	GGD21BR71H104KA02	0805	muRata	Capacitor, 100 nF, 50VDC, X7R, $\pm 15\%$
C11	NC	0				
R4	49.9 R	1	ARG03FTC49R9	0603	Viking	Resistor, 49.9 Ω , $\pm 1\%$, 0.1 W
R5	22 K	1	ARG03FTC2202	0603	Viking	Resistor, 22 K, $\pm 1\%$, 0.1 W
R6	3 K	1	ARG03FTC3001	0603	Viking	Resistor, 3 K, $\pm 1\%$, 0.1 W

Layout

Layout Guideline

- Both input capacitors and output capacitors must be placed to the device pins as close as possible.
- It is recommended to bypass the input pin to ground with a 0.1- μ F bypass capacitor.
- It is recommended to use wide and thick copper to minimize $I \times R$ drop and heat dissipation.
- Exposed pad must be connected to the PCB ground plane directly, the copper area must be as large as possible.

Layout Recommendations

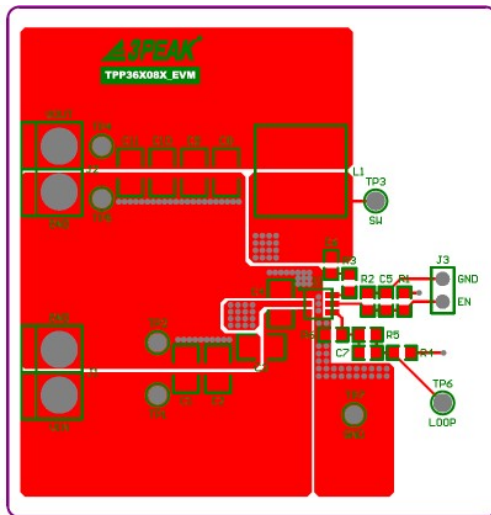

Top Layer

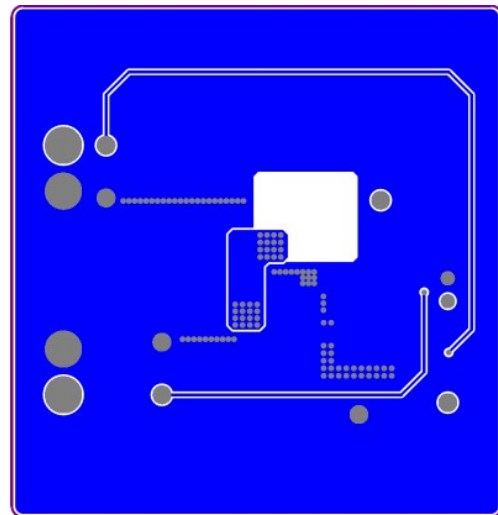

Bottom Layer

36-V Input, 2-A Synchronous Step-Down Voltage Regulator

Tape and Reel Information

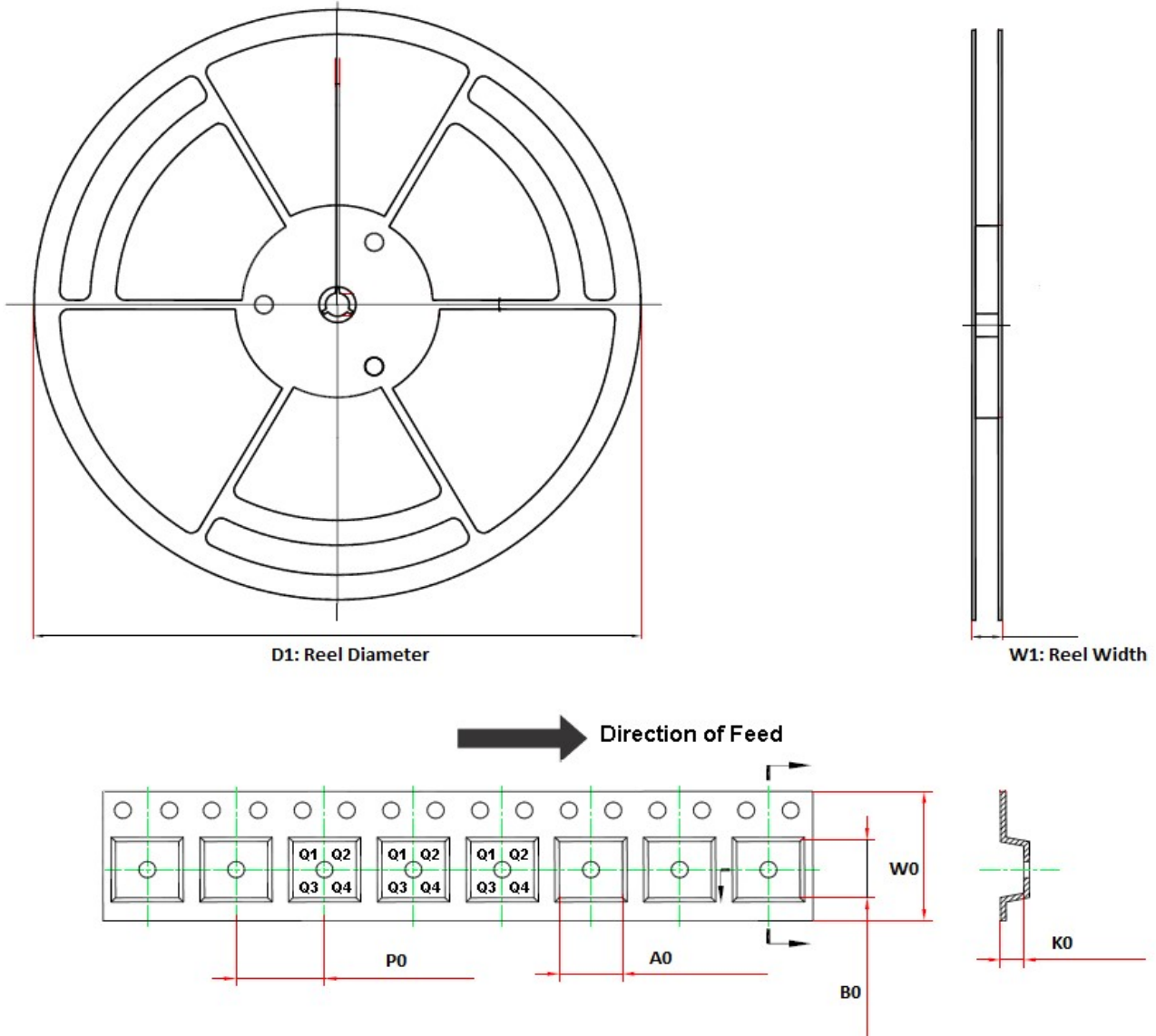

Order Number	Package	D1 (mm)	W1 (mm)	A0 (mm)	B0 (mm)	K0 (mm)	P0 (mm)	W0 (mm)	Pin1 Quadrant
TPP362080-T6TR	TSOT23-6	180.0	12.3	3.2	3.2	1.1	4.0	8.0	Q3
TPP362081-T6TR	TSOT23-6	180.0	12.3	3.2	3.2	1.1	4.0	8.0	Q3
TPP362082-T6TR	TSOT23-6	180.0	12.3	3.2	3.2	1.1	4.0	8.0	Q3
TPP362083-T6TR	TSOT23-6	180.0	12.3	3.2	3.2	1.1	4.0	8.0	Q3

36-V Input, 2-A Synchronous Step-Down Voltage Regulator

Package Outline Dimensions

TSOT23-6

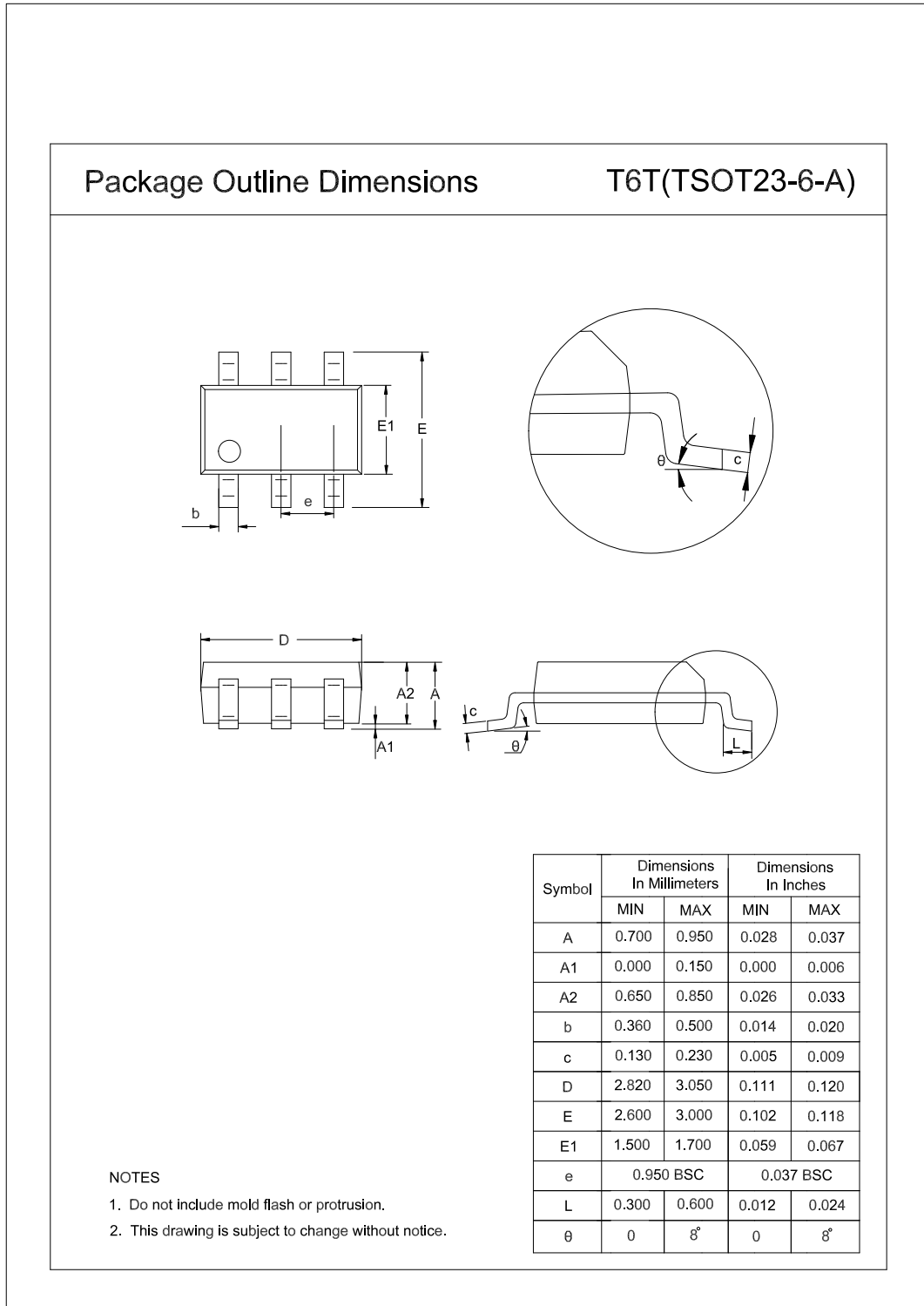

36-V Input, 2-A Synchronous Step-Down Voltage Regulator**Order Information**

Order Number	Operating Temperature Range	Package	Marking Information	MSL	Transport Media, Quantity	Eco Plan
TPP362080-T6TR	-40 to 125°C	TSOT23-6	320	MSL3	Tape and Reel, 3000	Green
TPP362081-T6TR	-40 to 125°C	TSOT23-6	321	MSL3	Tape and Reel, 3000	Green
TPP362082-T6TR	-40 to 125°C	TSOT23-6	322	MSL3	Tape and Reel, 3000	Green
TPP362083-T6TR	-40 to 125°C	TSOT23-6	323	MSL3	Tape and Reel, 3000	Green

Green: 3PEAK defines "Green" to mean RoHS compatible and free of halogen substances.

3PEAK and the 3PEAK logo are registered trademarks of 3PEAK INCORPORATED. All other trademarks are the property of their respective owners.

36-V Input, 2-A Synchronous Step-Down Voltage Regulator

This page intentionally left blank

单击下面可查看定价，库存，交付和生命周期等信息

[>>3PEAK\(思瑞浦\)](#)