

NOTES:

- MATERIAL:
 - HOUSING: THERMOPLASTIC, HIGH TEMP.UL94V-0; COLOR:WHITE.
 - ACTUATOR: THERMOPLASTIC, HIGH TEMP.UL94V-0; COLOR:BLACK.
 - CONTACT: COPPER ALLOY
 - FITTING NAIL: COPPER ALLOY
- FINISH:
 - CONTACT:
 - 50u" MIN. NICKEL UNDERPLATING OVERALL.
 - 1: 3u" MIN. GOLD PLATING ON CONTACT
 - 1u" MIN. PLATING GOLD FLASH ON SMT
 - M: 3u" MIN. GOLD PLATING ON CONTACT
 - 1u" MIN. PLATING GOLD FLASH ON SMT
 - FITTING NAIL:
 - 100~200u" TIN PLATING ON SOLDER TAILS(LEAD FREE).
 - 50~100u" NICKEL UNDERPLATING OVERALL.
- SPEC. PLS. REFER TO PS-51539-XXXXX-001
- PACKAGE PLS. REFER TO 51539-XXXXX-TRP

5. PART NUMBER

51539-XXX X X-001

NO OF CKT CONTACT PLATING

PACKING 1: 3u" GOLD ON CONTACT AND SOLDER FOR SELECTIVENESS PLATING

0:TAPE REEL M: 3u" GOLD ON CONTACT AND SOLDER FOR SELECTIVENESS PLATING

1:TUBE

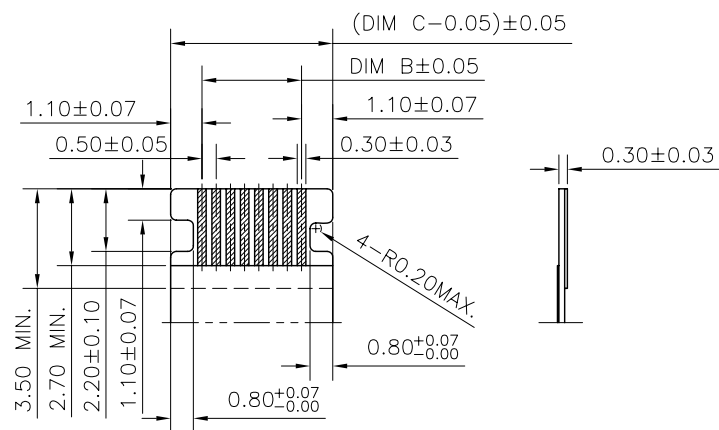
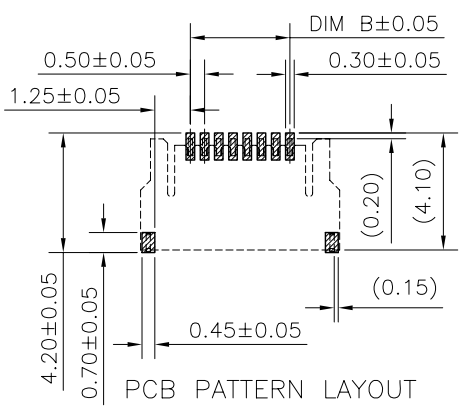
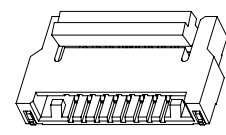

RECOMMENDED FPC/FFC DIMENSIONS
GENERAL TOLERANCE ±0.05

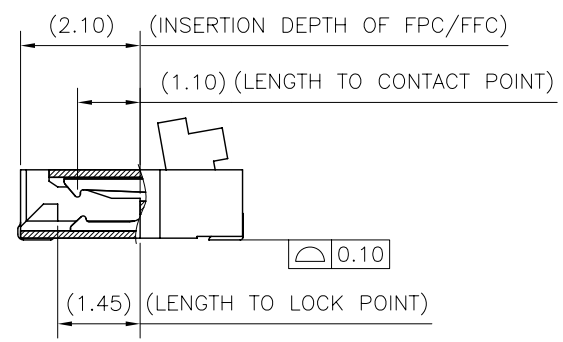

SECTION A-A
SCALE 6:1

CKT	DIM A	DIM B	DIM C	DIM D	DIM E
4	5.00	1.50	3.75	4.46	2.40
5	5.50	2.00	4.25	4.96	2.90
6	6.00	2.50	4.75	5.46	3.40
7	6.50	3.00	5.25	5.96	3.90
8	7.00	3.50	5.75	6.46	4.40
9	7.50	4.00	6.25	6.96	4.90
10	8.00	4.50	6.75	7.46	5.40
11	8.50	5.00	7.25	7.96	5.90
12	9.00	5.50	7.75	8.46	6.40
13	9.50	6.00	8.25	8.96	6.90
14	10.00	6.50	8.75	9.46	7.40
15	10.50	7.00	9.25	9.96	7.90
16	11.00	7.50	9.75	10.46	8.40
17	11.50	8.00	10.25	10.96	8.90
18	12.00	8.50	10.75	11.46	9.40
19	12.50	9.00	11.25	11.96	9.90
20	13.00	9.50	11.75	12.46	10.40
21	13.50	10.00	12.25	12.96	10.90
22	14.00	10.50	12.75	13.46	11.40
23	14.50	11.00	13.25	13.96	11.90
24	15.00	11.50	13.75	14.46	12.40
25	15.50	12.00	14.25	14.96	12.90
26	16.00	12.50	14.75	15.46	13.40
27	16.50	13.00	15.25	15.96	13.90
28	17.00	13.50	15.75	16.46	14.40
29	17.50	14.00	16.25	16.96	14.90
30	18.00	14.50	16.75	17.46	15.40

一般公差 TOOLERANCES X ±0.50 XX ±0.15 X ±0.25 XXX ±0.10 ANGLES ±2°		宏致電子股份有限公司 Aces Electronics Co.,Ltd.	
檢驗尺寸標示 SYMBOLS INDICATE CLASSIFICATION DIMENSION	品名 (TITLE) 0.5mm Pitch Easy On FFC/FPC Conn.	製圖 (DR) 14/11/06 ZHOUQUAN	審核 (CHKD) DAVID
MARK IS CRITICAL DIM. MARK IS MAJOR DIM.	圖號 (DWG NO.) 51539-XXXXX-001	核准 (APPD) FRANK	
表面處理 (FINISH)	比例 (SCALE) 3:1	單位 (UNITS) mm	張數 (SHEET) 1 OF 1
			SIZE A4
			REV C

单击下面可查看定价，库存，交付和生命周期等信息

[>>ACES\(宏致\)](#)