

RECOMMENDED PCB LAYOUT

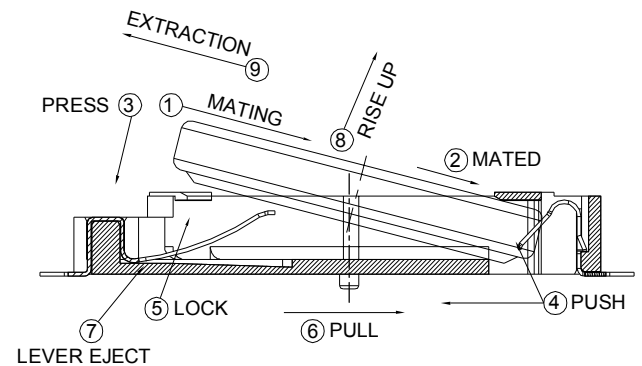

SECTION A-A

HOW TO MATE AND UNMATE

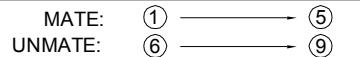

NOTES:

1. MATERIAL:
 - 1.1 CONTACT: PHOSPHOR BRONZE.
 - 1.2 HOUSING: HIGH TEMPERATURE THERMOPLASTIC.
2. FINISH:
 - 2.1 CONTACT AREA:
 - 50u"~100u" NICKEL UNDER PLATING OVERALL.
 1. GOLD FLASH ON CONTACT.
 - 2.2 SOLDER AREA:
 - 50u"~100u" NICKEL UNDER PLATING OVERALL.
 1. GOLD FLASH ON CONTACT.
3. SPEC. PLS REFER TO PS-53014-XXXX-XXX
4. PACKAGE PLS REFER TO 53011-002XX-05-TRP
5. PART NUMBER

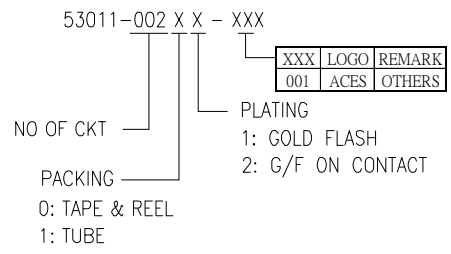

QUALITY SYMBOLS MAJOR Ⓢ CRITICAL Ⓢ GENERAL TOLERANCES (UNLESS SPECIFIED) X. ±0.5 X ±0.25 .XX ±0.15 .XXX ±0.1 ANGLES ±2°	DRAWN BY Rong, Li Ping	DATE 19/03/05	
	CHECKED BY Lu, Jing Quan	DATE 18/11/01	
	APPROVED BY hsieh, fu yu	DATE 18/11/01	
	UNITS mm		SIZE A4
	SCALE 4 : 1	SHEET NO. 1 OF 1	REV E
			RFQ NO. X
			PART NO. SEE NOTES
			DWG NO. 53011-002XX-XXX

单击下面可查看定价，库存，交付和生命周期等信息

[>>ACES\(宏致\)](#)