

NOTES:

1. MATERIAL:
 - 1.1 HOUSING: THERMOPLASTIC, HIGH TEMP.UL94V-0; COLOR:WHITE.
 - 1.2 ACTUATOR: THERMOPLASTIC, HIGH TEMP.UL94-0; COLOR:BLACK.
 - 1.3 CONTACT: COPPER ALLOY
2. FINISH:
 - 2.1 CONTACT:
 - M: 3u" MIN. PLATING GOLD ON CONTACT
 - B: 5u" MIN. PLATING GOLD ON CONTACT
 - 1u" MIN. PLATING GOLD ON SOLDER
 - 50~120u" NICKEL PLATING OVERALL
3. SPEC. PLS. REFER TO PS-51688-XXXXX-XXX
4. PACKAGE PLS. REFER TO 51688-XXXXX-XX-TRP
5. PART NUMBER

51688-XXX X X -XXX



NO OF CKT: NO OF CKT
 PACKING: 0:TAPE & REEL
 PLATING: M:3u" GOLD ON CONTACT AND SOLDER FOR SELECTIVENESS PLATING; B:5u" GOLD ON CONTACT AND SOLDER FOR SELECTIVENESS PLATING

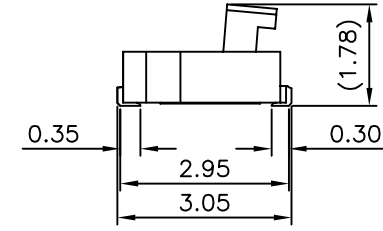

QUALITY SYMBOLS MAJOR Ⓢ CRITICAL Ⓢ	DRAWN BY Tsai, Wang Kun	DATE 20/05/27	
	CHECKED BY Liu, Yuan Huang	DATE 20/05/27	
GENERAL TOLERANCES (UNLESS SPECIFIED) X. ±0.50 .X ±0.25 .XX ±0.15 .XXX ±0.10 ANGLES ±2°	APPROVED BY Wang, Chun Sheng	DATE 20/05/27	TITLE 0.3MM PITCH ZIF BACK-FLIP FPC CONN SMT R/A D/C
	UNITS mm		SIZE A4
SCALE 1:1	SHEET NO. 1 OF 3	REV C	PART NO. 51688-XXXXX-XXX

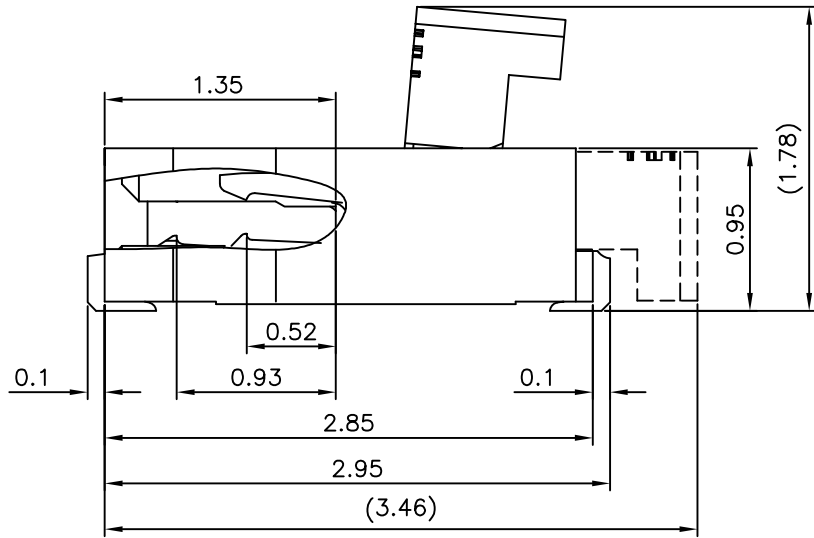

SCALE 3:1

PIN NO. CKT FOR DOWN CONTACT

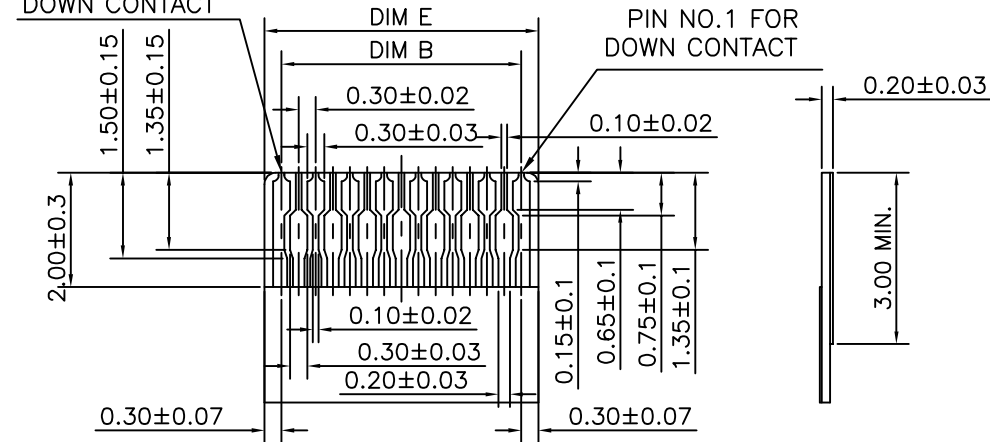

APPLICABLE FPC RECOMMENDED DIM
(GENERAL TOLERANCE: ±0.05mm)

CKT	Dim A	Dim B	Dim C	Dim D	Dim E
7	3.60	1.80	1.20	2.43	2.40
9	4.20	2.40	1.80	3.03	3.00
11	4.80	3.00	2.40	3.63	3.60
13	5.40	3.60	3.00	4.23	4.20
15	6.00	4.20	3.60	4.83	4.80
17	6.60	4.80	4.20	5.43	5.40
19	7.20	5.40	4.80	6.03	6.00
21	7.80	6.00	5.40	6.63	6.60
23	8.40	6.60	6.00	7.23	7.20
25	9.00	7.20	6.60	7.83	7.80
27	9.60	7.80	7.20	8.43	8.40
29	10.20	8.40	7.80	9.03	9.00
31	10.80	9.00	8.40	9.63	9.60
33	11.40	9.60	9.00	10.23	10.20
35	12.00	10.20	9.60	10.83	10.80
37	12.60	10.80	10.20	11.43	11.40
39	13.20	11.40	10.80	12.03	12.00
41	13.80	12.00	11.40	12.63	12.60
45	15.00	13.20	12.60	13.83	13.80
51	16.80	15.00	14.40	15.63	15.60

QUALITY SYMBOLS MAJOR CRITICAL	DRAWN BY Tsai, Wang Kun	DATE 20/05/27	
	CHECKED BY Liu, Yuan Huang	DATE 20/05/27	
GENERAL TOLERANCES (UNLESS SPECIFIED) X. ±0.50 .X ±0.25 .XX ±0.15 .XXX ±0.10 ANGLES ±2°	APPROVED BY Wang, Chun Sheng	DATE 20/05/27	TITLE 0.3MM PITCH ZIF BACK-FLIP FPC CONN SMT R/A D/C
	UNITS mm		SIZE A4
SCALE 1:1	SHEET NO. 2 OF 3	REV C	PART NO. 51688-XXXXX-XXX

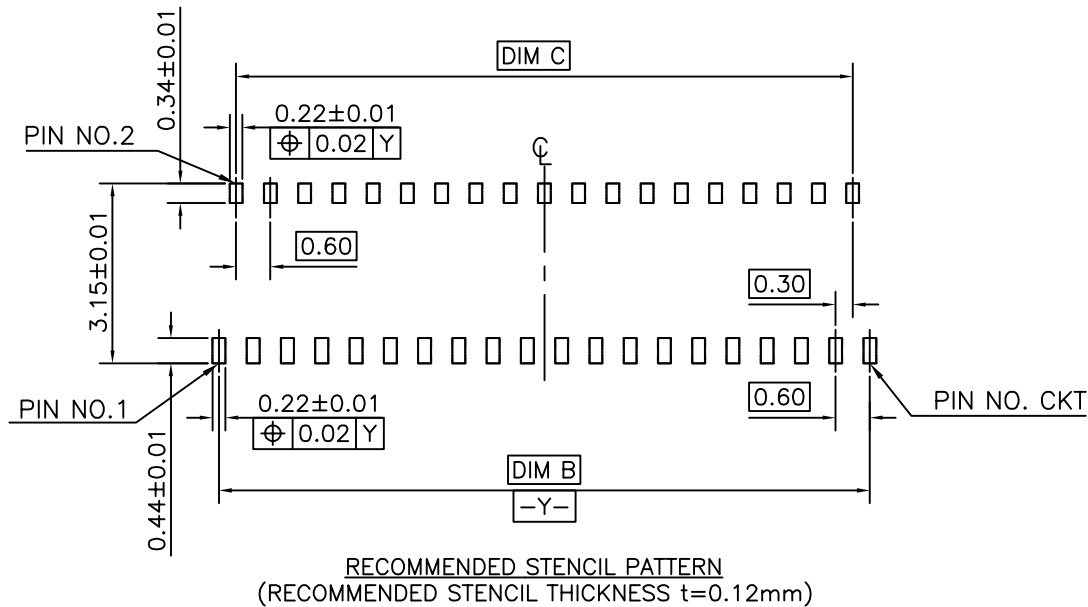
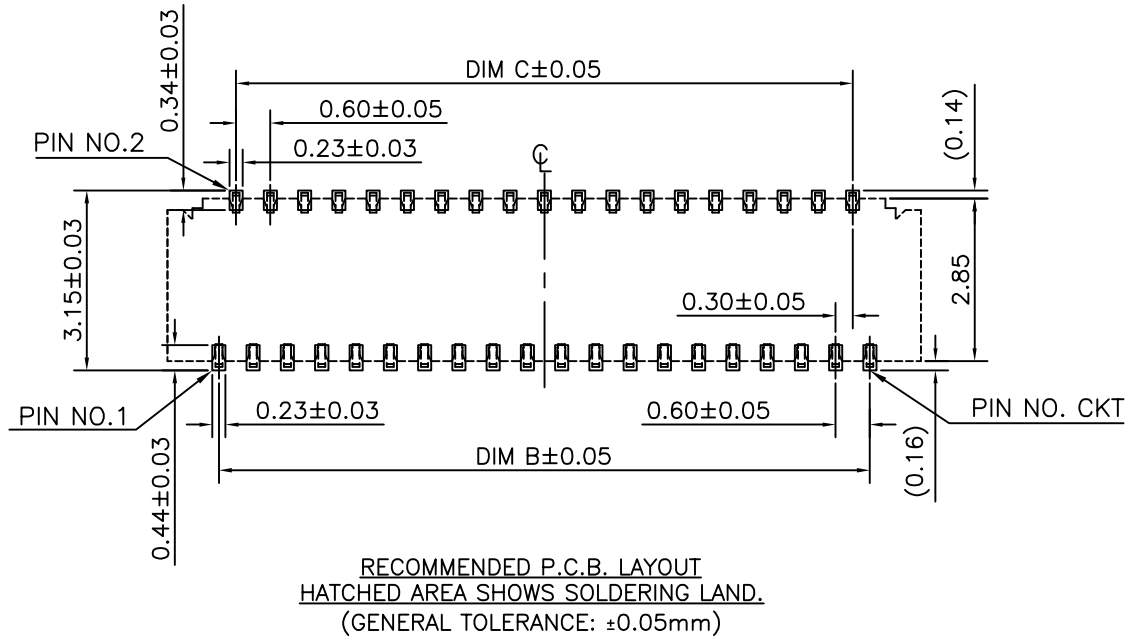

QUALITY SYMBOLS MAJOR CRITICAL	DRAWN BY	DATE				
	Tsai, Wang Kun	20/05/27				
GENERAL TOLERANCES (UNLESS SPECIFIED) X. ±0.50 .X ±0.25 .XX ±0.15 .XXX ±0.10 ANGLES ±2°	CHECKED BY	DATE	TITLE 0.3MM PITCH ZIF BACK-FLIP FPC CONN SMT R/A D/C			
	Liu, Yuan Huang	20/05/27				
	APPROVED BY	DATE	UNITS		SIZE	DWG NO.
	Wang, Chun Sheng	20/05/27	mm		A4	NA
	SCALE	SHEET NO.	1:1	3 OF 3	REV	PART NO.
					C	51688-XXXXX-XXX

单击下面可查看定价，库存，交付和生命周期等信息

[>>ACES\(宏致\)](#)