

- NOTES:
- MATERIAL: COPPER ALLOY, THICKNESS 0.20±0.01.
 - PLATING:
 - 30u" MIN. NICKEL UNDERPLATING OVERALL
 - L: 80u" MIN. PURE TIN PLATING OVERALL
 - C: 15u" GOLD PLATING ON CONTACT AND SELECT MATTE TIN IN CRIMP AREA.
 - D: 30u" GOLD PLATING ON CONTACT AND SELECT MATTE TIN IN CRIMP AREA.
 - COMPONENT LOAD PER REEL: XXX PCS.
 - APPLICABLE WIRE RANGE:
 - 001 STANDARD: AWG#20~24
 - 002 STANDARD: AWG#26~30
 - INSULATION O.D.: ø1.85mm (MAX.)
 - HOUSING P/N: 57958-XXXHXXX-XXX & 57960-XXXHXXX-001
 - SPEC. PLS. REFER TO PS-57957-XXXXX-XXX
 - PART NUMBER

TYPE	X	X-	XXX	XXX	AWG
5:NONE				001	#20~24
				002	#26~30

PLATING
 L: PURE TIN PLATING
 C: 15u" GOLD PLATING
 D: 30u" GOLD PLATING

MATERIAL
 1:PHOSPHOR BRONZE

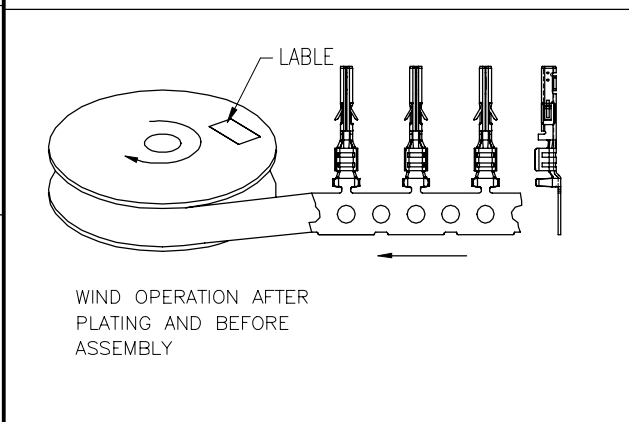

P/N	Dim A	Dim B	Dim C	Dim D	Dim E	Dim F	AWG
57958-T5XX-001	2.29	2.54	0.76	1.91	2.08	0.64	#20~24
57958-T5XX-002	1.91	2.10	0.64	1.47	1.65	0.51	#26~30

QUALITY SYMBOLS MAJOR Ⓢ CRITICAL Ⓢ GENERAL TOLERANCES (UNLESS SPECIFIED) X ±0.5 X ±0.35 .XX ±0.25 .XXX ±0.1 ANGLES ±2°	DRAWN BY Lei,shanjun DATE 22/06/28		
	CHECKED BY Lu,Jing Quan DATE 22/06/28		TITLE 3.0mm PITCH WTB CRIMP TERMINAL
APPROVED BY hsieh,fu yu DATE 22/06/28	UNITS mm	SIZE A4	RFQ NO. N/A
SCALE 1:1	SHEET NO. 1 OF 1	REV B	DWG NO. 57958-TXXX-XXX

单击下面可查看定价，库存，交付和生命周期等信息

[>>ACES\(宏致\)](#)