

SECTION A-A

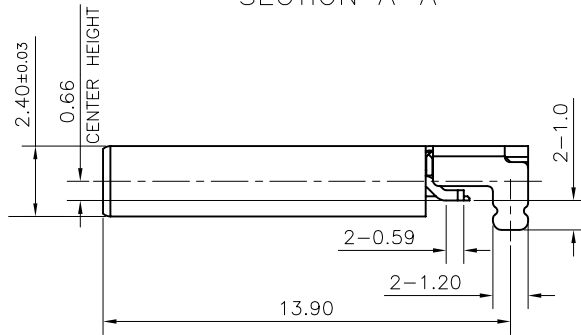
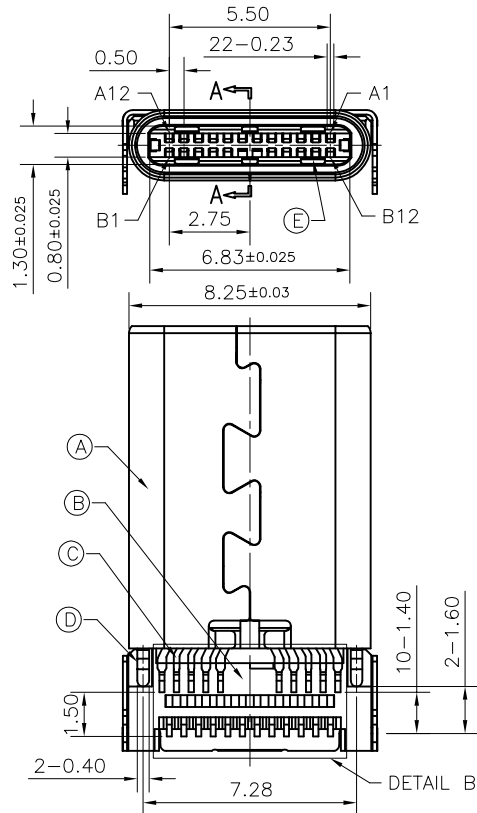

NOTES:

1. MATERIAL: SEE THE TABLE
2. PLATING:
  - 2.1 TERMINAL:
    - 50u" MIN. NICKEL PLATING OVERALL.
    - 100u" MIN MATTE TIN ON SOLDERING AREA.
  - D: 30u" MIN. GOLD ON CONTACT.
  - 2: GOLD FLASH ON CONTACT.
3. ELECTRICAL CHARACTERISTICS:
  - 3.1 LOW LEVEL CONTACT RESISTANCE:
    - INITIAL: 40mΩ FOR ALL CONTACT MAX.
    - AFTER: 10mΩ MAX. CHANGE.
  - 3.2 DIELECTRIC WITHSTANDING VOLTAGE:
    - 100 VAC FOR 1 MINUTE SEA LEVEL.
  - 3.3 INSULATION RESISTANCE: 100MΩ MIN.
  - 3.4 CURRENT RATING : VBUS AND GND CONTACT RATED AT 1.25A EA. PARALLELED FOR A TOTAL OF 5A
- 4 MECHANICAL CHARACTERISTICS :
  - 4.1 INSERTION FORCE : 5N MIN. 20N MAX.
  - 4.2 EXTRACTION FORCE : 8N MIN. 20N MAX (INITIAL) . 6N MIN. 20N MAX. (AFTER LIFE TEST)
5. LIFE TEST: 10000 CYCLES MIN
6. SPEC. PLS. REFER TO SPEC-55907-XXXXX-XXX
7. PACKAGE PLS REFER TO 31896-022XX-XXX-PCK
8. PART NUMBER
  - 31896-022 X X-XXX

CKTS:  PLATING  001: NONE  
 022: 22PIN D: 30u" MIN. GOLD ON CONTACT  
 PACKING  2: GOLD FLASH ON CONTACT  
 7: TAPE & REEL WITH CAP

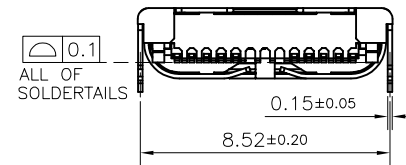

NO.	DESCRIPTION	QTY	MATERIAL	PLATING & COLOR
F	CAP	1	LCP,UL94V-0	BLACK
E	EMC SPRING	1	STAINLESS STEEL SUS304, T=0.10mm	50u" MIN. NICKEL PLATING OVERALL.
D	LATCH	1	STAINLESS STEEL SUS301, T=0.35mm	50u" MIN. SOLDERABLE NICKEL PLATING OVERALL.
C	TERMINAL	22	COPPER ALLOY C7035 T=0.15mm	SEE THE NOTES
B	HOUSING	1	LCP,UL94V-0	BLACK
A	SHELL	1	STAINLESS STEEL SUS301, T=0.15mm	50u" MIN. NICKEL PLATING OVERALL.

A12	GND	B1	GND
A11	SSRXp2	B2	SSTXp2
A10	SSRXn2	B3	SSTXn2
A9	VBUS	B4	VBUS
A8	SBU1	B5	CC2
A7	Dn1		
A6	Dp1		
A5	CC1	B8	SBU2
A4	VBUS	B9	VBUS
A3	SSTXn1	B10	SSRXn1
A2	SSTXp1	B11	SSRXp1
A1	GND	B12	GND
DIN1	SIGNAL NAME	PIN	SIGNAL NAME

<b>QUALITY SYMBOLS</b> MAJOR Ⓜ CRITICAL Ⓢ	DRAWN BY Hsu, Wei Chun	DATE 20/12/24	
	CHECKED BY Chang, Chun Wei	DATE 20/12/24	
<b>GENERAL TOLERANCES (UNLESS SPECIFIED)</b> X ±0.5 .X ±0.25 .XX ±0.15 .XXX ±0.1 ANGLES ±2°	APPROVED BY Kuo, Rong Hsun	DATE 20/12/24	<b>TITLE</b> USB TYPE C PLUG , DUAL SMT TYPE CH= 0.66 mm
	UNITS mm		SIZE A4
SCALE 4:1	SHEET NO. 1 OF 1	REV B	PART NO. SEE NOTES

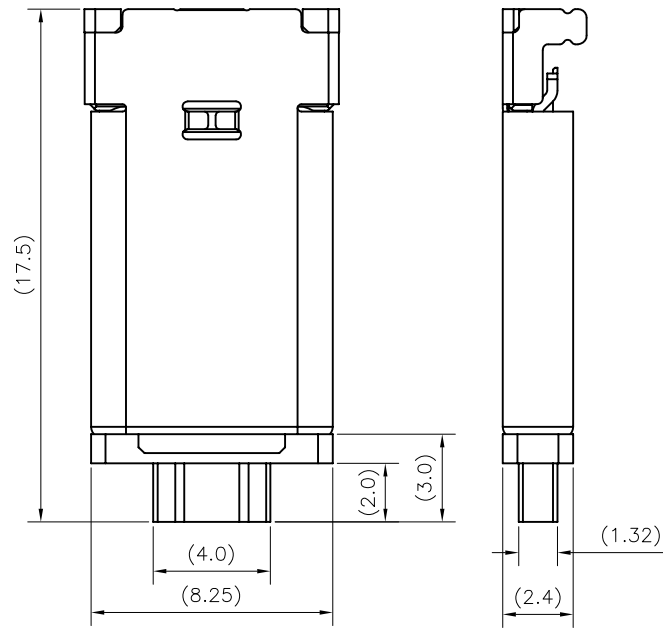

WITH CAP DRAWING

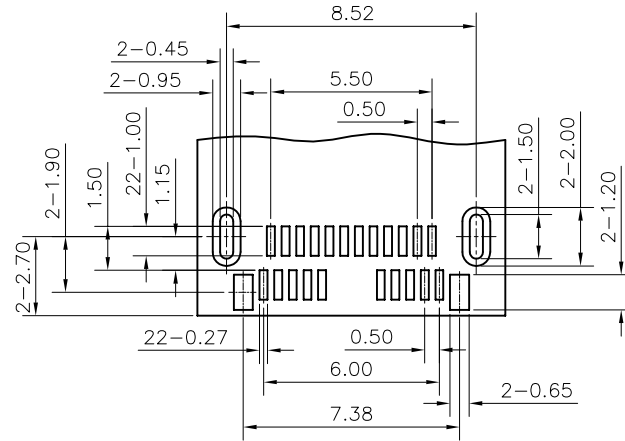

RECOMMENDED PCB DIMENSIONS (REF.)  
GENERAL TOLERANCE  $\pm 0.05$

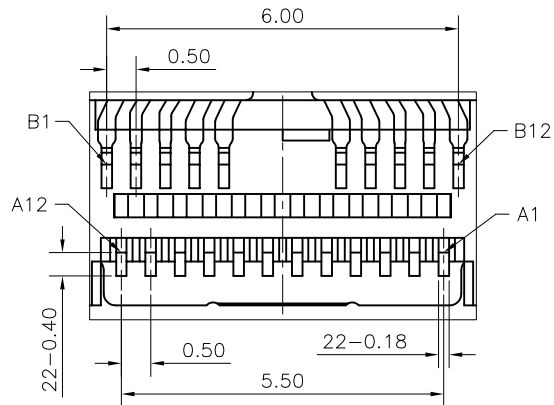

DETAIL B  
SCALE 8:1

<b>QUALITY SYMBOLS</b> MAJOR CRITICAL	DRAWN BY Hsu, Wei Chun	DATE 20/12/24	
	CHECKED BY Chang, Chun Wei	DATE 20/12/24	
<b>GENERAL TOLERANCES (UNLESS SPECIFIED)</b> X. $\pm 0.5$ .X $\pm 0.25$ .XX $\pm 0.15$ .XXX $\pm 0.1$ ANGLES $\pm 2^\circ$	APPROVED BY Kuo, Rong Hsun	DATE 20/12/24	<b>TITLE</b> USB TYPE C PLUG , DUAL SMT TYPE CH= 0.66 mm
	UNITS mm		SIZE A4
SCALE 4 : 1	SHEET NO. 2 OF 2	REV B	PART NO. SEE NOTES

单击下面可查看定价，库存，交付和生命周期等信息

[>>ACES\(宏致\)](#)