

NOTES:

1. MATERIAL:

- 1.1 HOUSING 1: THERMOPLASTIC, HIGH TEMP.,UL94 HB.
- 1.2 HOUSING 2: THERMOPLASTIC, HIGH TEMP.,UL94 HB.
- 1.3 HOUSING 3: THERMOPLASTIC, HIGH TEMP.,UL94 HB.
- 1.4 RUBBER 1: SILICONE.
- 1.5 RUBBER 2: SILICONE.

2. NON-WATERPROOF TYPE WITHOUT RUBBER2.

3. SPEC. PLS. REFER TO PS-92201-XXXX-XXX

4. PACKAGE PLS. REFER TO 92201-XXXX-XXX-PCK

5. PART NUMBER

92201-XXX X X-XXX

NO OF CKT

007.CKT

PACKING

3:BAG

PLAIN

9: NONE

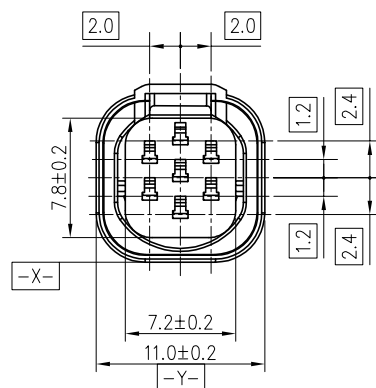
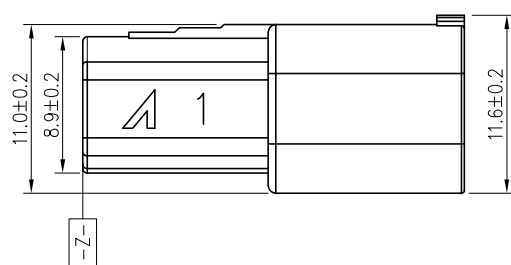
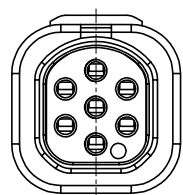

XXX	HOUSING 1	HOUSING 2	HOUSING 3	RUBBER 1	RUBBER 2	NOTES
001	GREEN	GREEN	GREEN	GRAY	WITHOUT	NON-WATERPROOF
002	WHITE		WITHOUT	WITHOUT		
003	GREEN		GREEN	GRAY	GRAY	WATERPROOF
004	WHITE		GREEN	GRAY	GRAY	WATERPROOF
005	GREEN		GREEN	GRAY	GRAY	WATERPROOF
006	WHITE		GREEN	GRAY	GRAY	WATERPROOF
007	YELLOW		GREEN	GRAY	GRAY	WATERPROOF
008	RED		GREEN	GRAY	GRAY	WATERPROOF

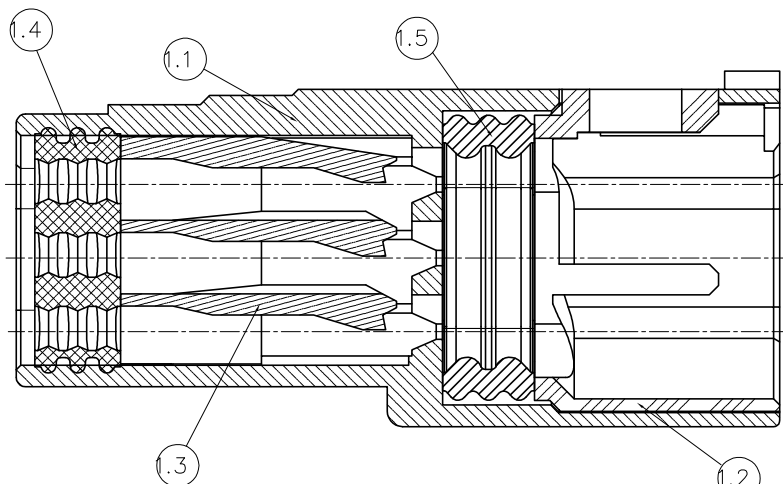

SECTION A-A
SCALE: 2:1

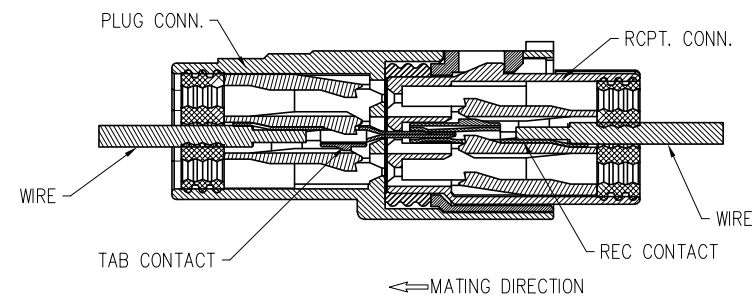

MATED CONDITION SECTION(REF.)
SCALE: 2:1

一般公差 TOLERANCES X ±0.50 .XX ±0.15 .X ±0.25 .XXX ±0.10 ANGLES ±2°		宏致電子股份有限公司 Aces Electronics Co.,Ltd.	
檢驗尺寸標示 SYMBOLS (M) INDICATE CLASSIFICATION DIMENSION (M) MARK IS CRITICAL DIM. (M) MARK IS MAJOR DIM.	品名 (TITLE) 2.4mm WTW Plug Conn.	製圖 (DR) 19/02/26 審核 (CHKD) WARLES	Leon
表面處理 (FINISH)	圖號 (DWG.NO) 92201-XXXX-XXX	核准 (APPD) WARLES	
比例 (SCALE) 2:1	單位 (UNITS) mm	張數 (SHEET) 1 OF 1	尺寸 (SIZE) A4 版本 (REV) C

单击下面可查看定价，库存，交付和生命周期等信息

[>>ACES\(宏致\)](#)