

RECOMMENDED PCB LAYOUT
GENERAL TOLERANCE ± 0.05

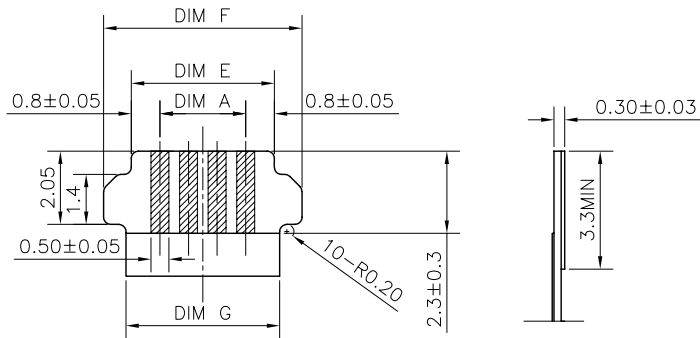
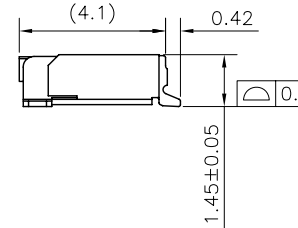
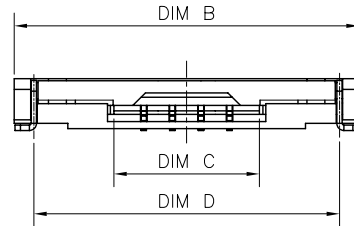
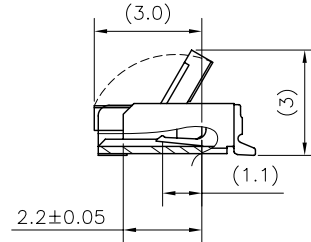
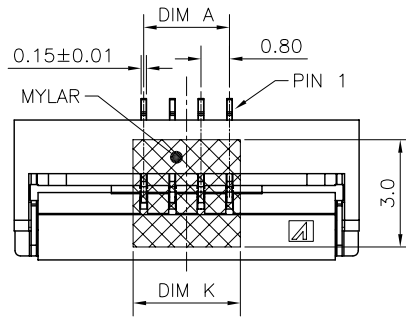

RECOMMENDED FPC/FFC DIMENSIONS
GENERAL TOLERANCE ± 0.05

NOTES:

1. MATERIAL:
 - 1.1 HOUSING: THERMOPLASTIC, HIGH TEMP., UL94V-0.
 - 1.2 ACTUATOR: THERMOPLASTIC, HIGH TEMP., UL94V-0.
 - 1.3 CONTACT: COPPER ALLOY
 - 1.4 FITTING NAIL: COPPER ALLOY
2. FINISH:
 - 2.1 CONTACT:
 - 50~100u" NICKEL UNDERPLATING OVERALL.
 - 1:GOLD FLASH PLATING.
 - N:100~200u" MIN. MATTE TIN PLATING (LEAD FREE)
 - D:30u"MIN. GOLD ON CONTACT AREA.
 - 2.2 FITTING NAIL:
 - 100~200u" MATT TIN PLATING ON SOLDER TAILS(LEAD FREE)
 - 50~100u" NICKEL UNDERPLATING OVERALL.
3. REFLOW SOLDER CAPABLE TO 260°C PER ACES SPEC.
4. SPEC. PLS. REFER TO PS-51503-XXXXX
5. PACKAGE PLS. REFER TO 51561-XXXXX-XX-TRP
6. PART NUMBER

51561-XXX	X	X-XXX	XXX	HOUSING MATERIAL&COLOR	ACTUATOR MATERIAL&COLOR	HALOGEN FREE
NO OF CKT			001	HALOGEN FREE PLASTIC & NATURAL	HALOGEN FREE PLASTIC & BLACK	HF
PACKING			PLATING			
0: TAPE & REEL			1: GOLD FLASH			
1: TUBE			N:MATTE TIN (LEAD FREE)			
4: TAPE & REEL WITH MYLAR			D:30u" MIN. GOLD ON CONTACT AREA			
5: TUBE WITH MYLAR						

CKT	DIM A	DIM B	DIM C	DIM D	DIM E	DIM F	DIM G	DIM H	DIM J	DIM K
26	20.00	27.25	21.67	26.15	21.60	23.15	21.90	25.66	27.66	
32	24.80	32.05	26.47	30.95	26.40	27.95	26.70	30.46	32.46	6
34	26.40	33.65	28.07	32.55	28.00	29.55	28.30	32.06	34.06	

一般公差 TOLERANCES X ± 0.5 XX ± 0.15 X ± 0.25 .XXX ± 0.1 ANGLES $\pm 2^\circ$		宏致電子股份有限公司 Aces Electronics Co.,Ltd.	
檢驗尺寸標示 SYMBOLS \odot \ominus INDICATE CLASSIFICATION DIMENSION \odot MARK IS CRITICAL DIM. \ominus MARK IS MAJOR DIM.	品名 (TITLE) 0.8 PITCH EASY ON FPC H=1.5mm TYPE 圖號 (DWG.NO) 51561-XXXXX-XXX	製圖 (DR) 15/11/24 審核 (CHKD) DAVID 核准 (APPD) FRANK	XUBIN DAVID FRANK
表面處理 (FINISH)	比例 (SCALE) 3:1 單位 (UNITS) mm		張數 (SHEET) 1 OF 1 尺寸 (SIZE) A4 版本 (REV) B

单击下面可查看定价，库存，交付和生命周期等信息

[>>ACES\(宏致\)](#)