



3.5(H)mm, 2.0mm-travel Type SSSS2 Series

Part number	SSSS213100		
Travel	2mm		
Actuator directions	Horizontal		
Actuator length	2mm		
Poles	1		
Positions	2		
Operating force	Refer to the dimensions.		
Changeover timing	Non shorting		
Soldering	Manual, Dip		
Operating temperature range	-40°C to +85°C		
Rating (max.)/(min.) (Resistive load)	0.3A 6V DC/50μA 3V DC		
Electrical performance	Contact resistance (Initial performance/After lifetime)	70mΩ max./130mΩ max.	
	Insulation resistance	100MΩ min. 500V DC	
	Voltage proof	500V AC for 1 minute	
Mechanical performance	Terminal strength	3N for 1 minute	
	Actuator strength	Operating direction	20N
		Pulling direction	10N
Durability	Operating life without load	10,000 cycles 100mΩ max.	
	Operating life with load (at max. rated load)	10,000 cycles 130mΩ max.	
Environmental performance	Cold	-20°C 500h	

Dry heat 85°C 500h

Damp heat 60°C, 90 to 95%RH 500h

Minimum order unit (pcs.) Japan 100

Export 10,000

Photo

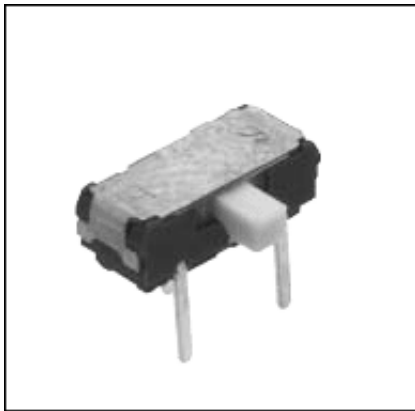

Dimensions

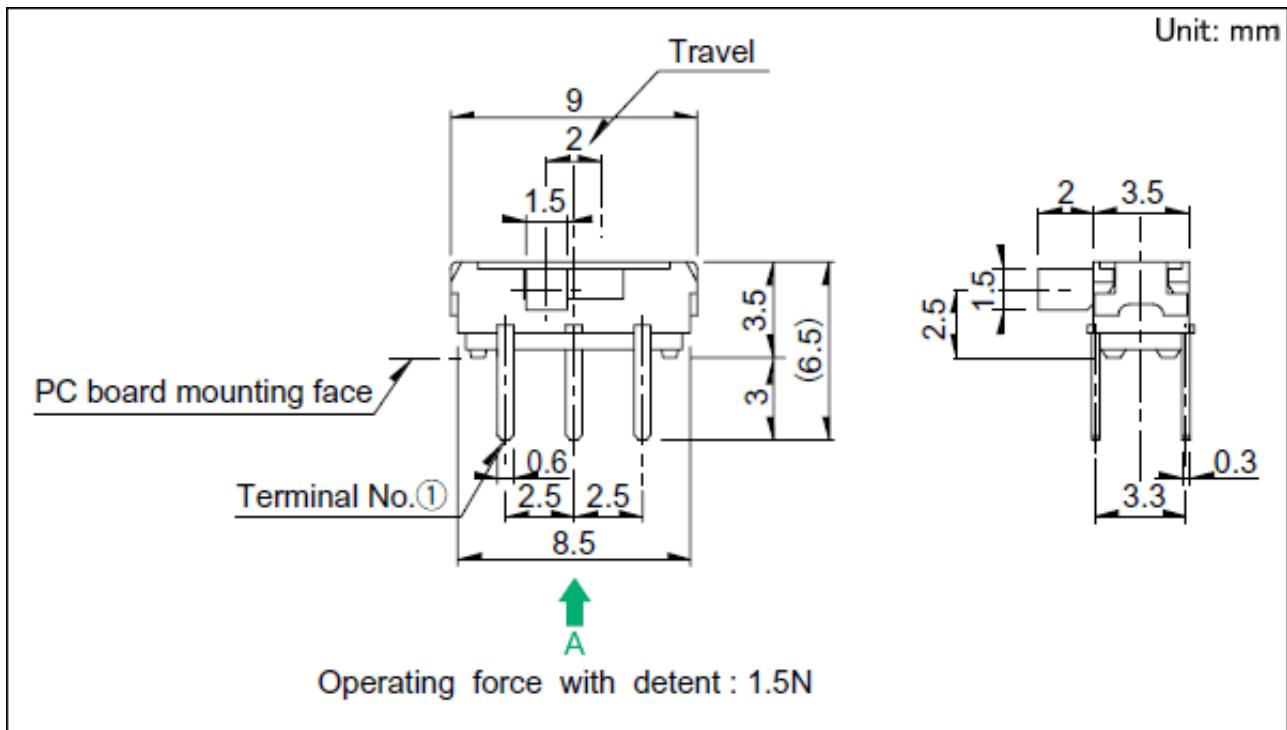

Mounting Hole Dimensions

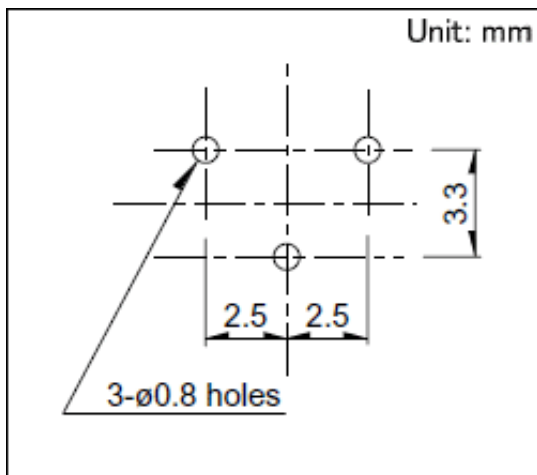

Viewed from direction A in the dimensions.

Circuit Diagram

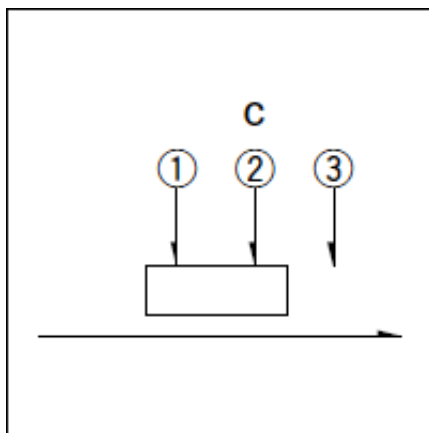

Packing Specifications

Bulk

Number of packages (pcs.)	1 case / Japan	2,000
	1 case / export packing	10,000

Export package measurements (mm) 400×270×290

Soldering Conditions

Reference for Dip Soldering

Items	Preheating temperature	100°C
	Preheating time	60s max.
Dip soldering	Soldering temperature	260±5°C
	Duration of immersion	3±1s

Reference for Hand Soldering

Soldering temperature	350±10℃
-----------------------	---------

Soldering time	4s max.
----------------	---------

Notes are common to this series/models.

1. This site catalog shows only outline specifications. When using the products, please obtain formal specifications for supply.
2. Please place purchase orders per minimum order unit (integer).
3. Products other than those listed in the above chart are also available. Please contact us for details.

单击下面可查看定价，库存，交付和生命周期等信息

[>>ALPS Electric\(阿尔卑斯\)](#)