

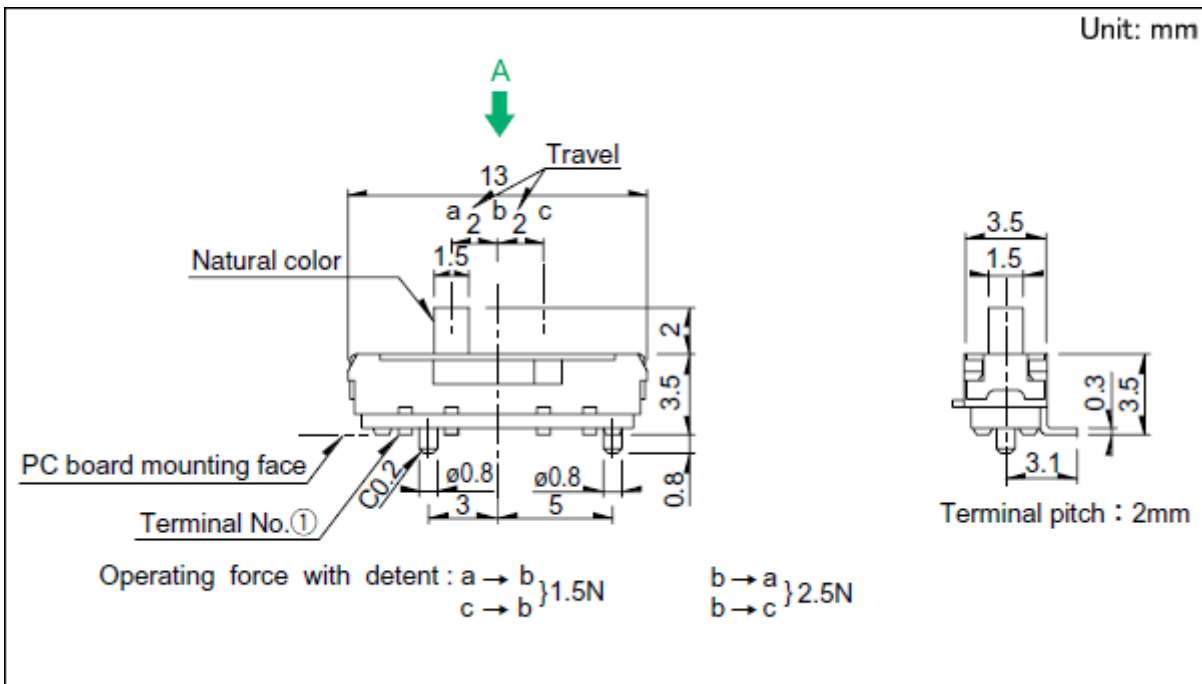

3.5(H)mm, 2.0mm-travel Type SSSS2 Series

Travel	2mm		
Actuator directions	Vertical		
Actuator length	2mm		
Poles	1		
Positions	3		
Operating force	Refer to the dimensions.		
Changeover timing	Non shorting		
Soldering	Reflow		
Operating temperature range	-40°C to +85°C		
Rating (max.)/(min.) (Resistive load)	0.3A 6V DC/50μA 3V DC		
Electrical performance	Contact resistance (Initial performance/After lifetime)	70mΩ max./130mΩ max.	
	Insulation resistance	100MΩ min. 500V DC	
	Voltage proof	500V AC for 1 minute	
Mechanical performance	Terminal strength	3N for 1 minute	
	Actuator strength	Operating direction	20N
		Pulling direction	10N
Durability	Operating life without load	10,000 cycles 100mΩ max.	
	Operating life with load (at max. rated load)	10,000 cycles 130mΩ max.	
Environmental performance	Cold	-20°C 500h	
	Dry heat	85°C 500h	
	Damp heat	60°C, 90 to 95%RH 500h	
Minimum order unit (pcs.)	Japan	1,000	

Dimensions



Land Dimensions

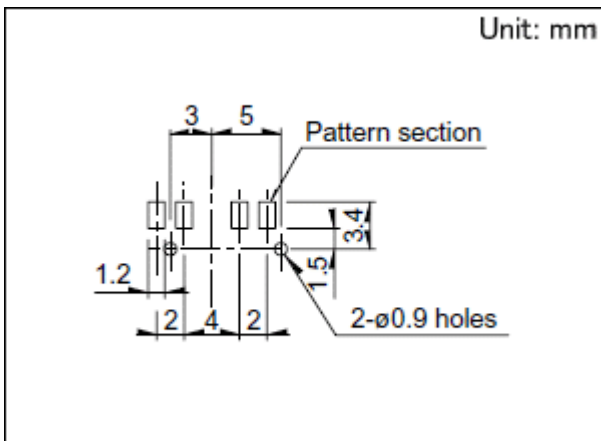

Viewed from direction A in the dimensions.

Circuit Diagram

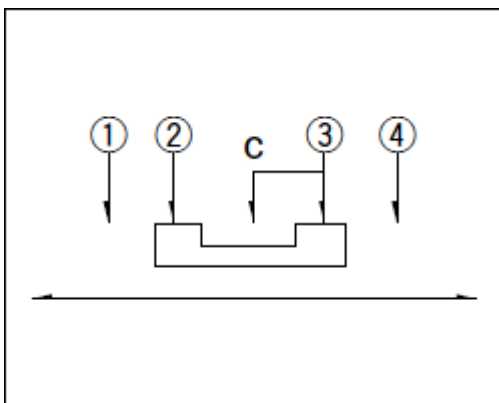

Packing Specifications

Taping

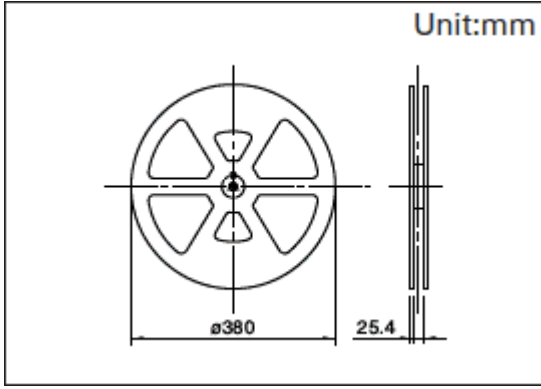

Number of packages 1 reel (pcs.)	1,000
1 case / Japan	2,000
1 case / export packing	4,000
Tape width (mm)	24
Export package measurements (mm)	406×406×190

Soldering Conditions

Example of Reflow Soldering Condition

1. Heating method

Double heating method with infrared heater.

2. Temperature measurement

Thermocouple 0.1 to 0.2 Φ CA (K) or CC (T) at soldering portion (copper foil surface). A heat resisting tape should be used for fixed measurement.

3. Temperature profile

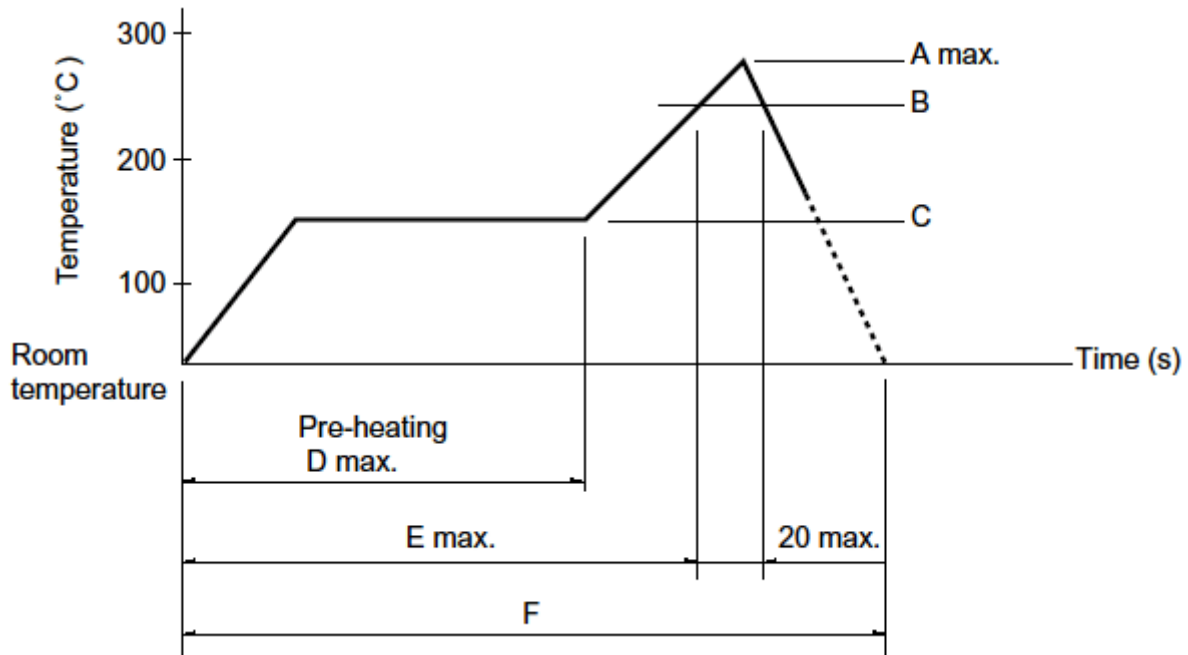

A(°C)	B(°C)	C(s)	D(°C)	E(°C)	F(s)
3s max.					
250	230	40	180	150	120

- (1) The condition mentioned above is the temperature on the mounting surface of a PC board. There are cases where the PC board's temperature greatly differs from that of the switch, depending on the PC board's material, size, thickness, etc. The above-stated conditions shall also apply to switch surface temperatures.
- (2) Soldering conditions differ depending on reflow soldering machines. Prior verification of soldering condition is highly recommended.

Reference for Hand Soldering

Soldering temperature	350±10°C
<hr style="border-top: 1px dashed #000;"/>	
Soldering time	4s max.

Notes are common to this series/models.

1. This site catalog shows only outline specifications. When using the products, please obtain formal specifications for supply.
2. Please place purchase orders per minimum order unit (integer).
3. Products other than those listed in the above chart are also available. Please contact us for details.

单击下面可查看定价，库存，交付和生命周期等信息

[>>ALPS Electric\(阿尔卑斯\)](#)