

REVISIONS					
REV	ECO	DESCRIPTION	DATE	BY	APPR
B1	-	RELEASED DRAWING	JUN-26-2014	BEN	TOMMY

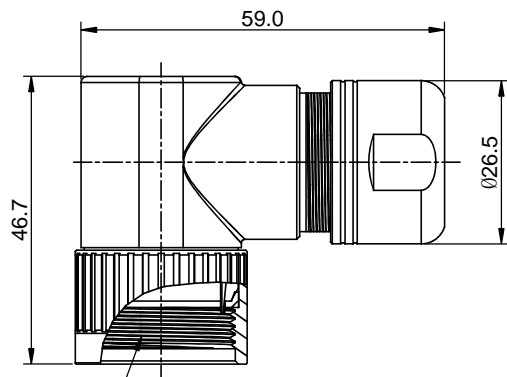

15/16-20 UNEF THREAD

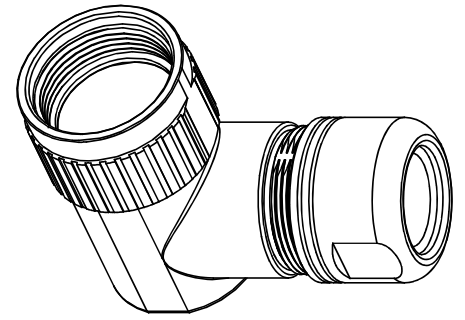
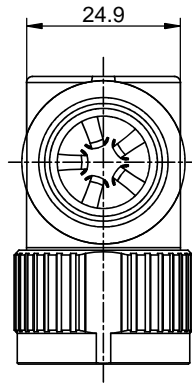

**NOTES : (UNLESS OTHERWISE SPECIFIED)**

1. MATERIAL :
  - 1.1. METAL NUT : AL ALLOY , NICKEL PLATED.
  - 1.2. GASKET : SILICONE RUBBER.
  - 1.3. METAL CLIP : STAINLESS STEEL.
  - 1.4. BACK SHELL : ZINC ALLOY, NICKEL PLATED.
  - 1.5. EMI SHIELDING RING : STAINLESS STEEL.
  - 1.6. O-RING : SILICONE RUBBER.
  - 1.7. GROMMET : RUBBER.
  - 1.8. CLAMP INSERT : THERMOPLASTIC UL94 V-0.
  - 1.9. END NUT : ZINC ALLOY , NICKEL PLATED.
2. ROHS COMPLIANT.
3. ALL DIMENSIONS ARE FOR REFERENCE USE ONLY.

P/N	SHIELDING RING	CABLE RANGE
RT0B-16CG-C1	WITHOUT	Ø9.0-Ø14.5mm
RT0B-16CG-C2	WITHOUT	Ø13.5-Ø17.0mm
RT0B-16CG-S1	WITH	Ø9.0-Ø14.5mm
RT0B-16CG-S2	WITH	Ø13.5-Ø17.0mm

QUANTITY	PART NUMBER	DESCRIPTION	ITEM
<b>MATERIALS LIST</b>			
UNLESS OTHERWISE SPECIFIED 1) All dimensions are in metric(mm). 2) Tolerances are as follows: 1 PL DEC ±0.30   Fractions ±1/64 2 PL DEC ±0.15   Angles ±1° 3 PL DEC ±0.08 3) Note reference =		<b>SIGNATURES</b> DRAWN: BEN CHECKED: ENGINEER: APPROVAL:	<b>DATE</b> JUN-26-2014
<b>MATERIAL SPECIFICATIONS:</b> THIS DRAWING IS SUPPLIED FOR INFORMATION ONLY. DESIGN FEATURES, SPECIFICATIONS AND PERFORMANCE DATA SHOWN HEREON ARE THE PROPERTY OF THE AMPHENOL CORPORATION. NO RIGHTS OF REPRODUCTION ARE IMPLIED. ALL DIMENSIONS ARE SUBJECT TO NORMAL MANUFACTURING VARIATIONS.		 Sine Systems - www.amphenol-sine.com 44724 Morley Drive Clinton Township, MI 48036	
<b>PROCESS SPECIFICATIONS:</b>		CUSTOMER:	ECO-MATE, ANGLE 90°, CORD GRIP, SIZE 16
<b>NEXT ASSY:</b>		SIZE: B C- SCALE: NONE	DWG NO: RT0B-16CG-xx REVISION: B1 SHEET 1 OF 1

TITLE: ECO-MATE, ANGLE 90° CORD GRIP, SIZE 16  
 DWG NO: RT0B-16CG-xx  
 REV: B1  
 SH: 1  
 OF: 1

单击下面可查看定价，库存，交付和生命周期等信息

[>>Amphenol\(安费诺\)](#)