

CUSTOMER DRAWING

REV	ECN	DESCRIPTION	DATE	MODIFIED
1		PRE-RELEASE	24/06/15	Robin Yuan
2		MODIFIED DIMENSION	22/07/15	Robin Yuan
3		ADD CODE AND ORDER	02/11/15	Robin Yuan
4			08/12/15	Robin Yuan

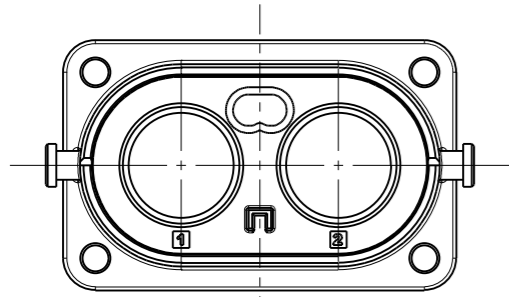

HVSL5 600 02 2 A
CODING A

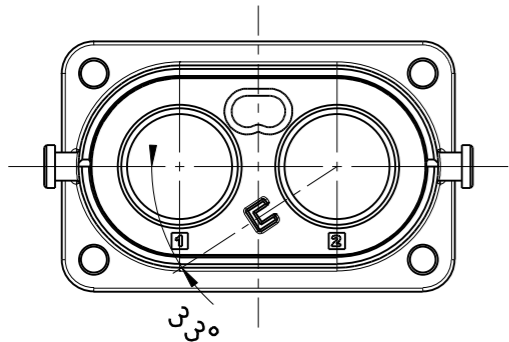

HVSL5 600 02 2 B
CODING B

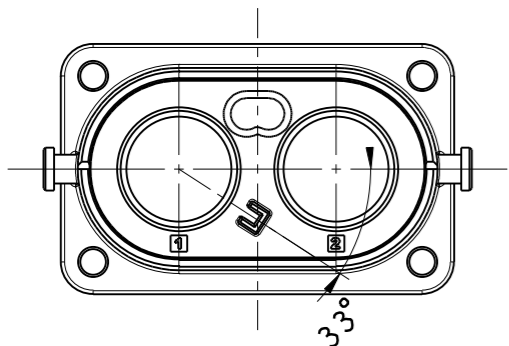

HVSL5 600 02 2 C
CODING C

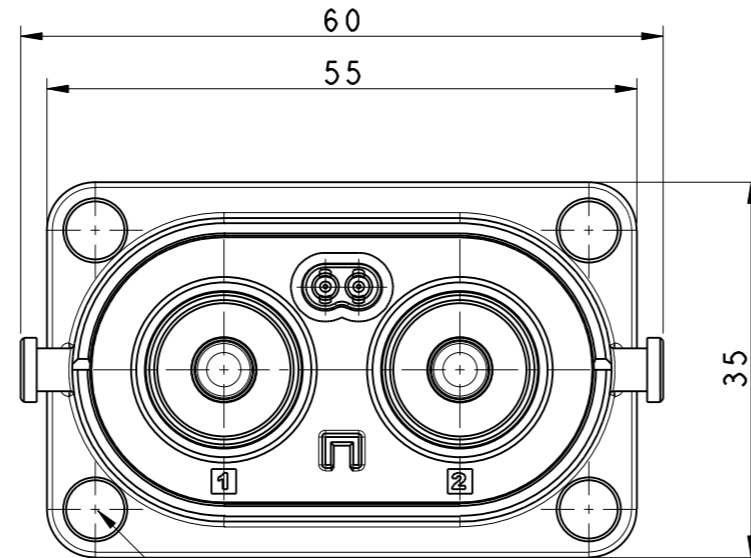

M3 SCREW
APPLICABLE

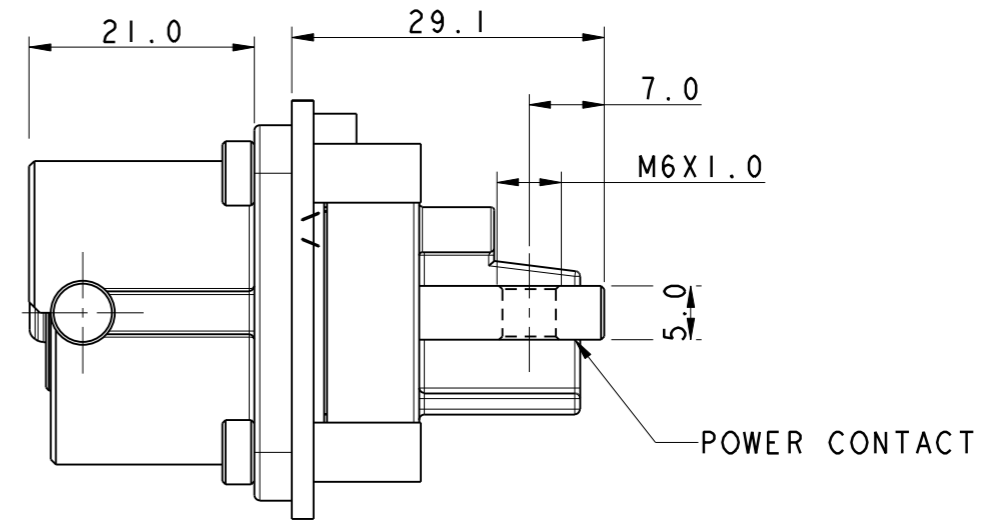

POWER CONTACT

HOW TO ORDER

HVSL5 600 02 2X X XX

A: CODING A 0: WITHOUT HVIL H6: STANDARD HOLE M6
 B: CODING B 1: WITH HVIL
 C: CODING C

NOTES:

- ELECTRONICAL CHARACTERISTICS:
 HIGH VOLTAGE RATED 1000 V DC MAX.
 CURRENT RATED 120 A MAX.
 WITHSTANDING VOLTAGE 3000 V AC
 PRODUCTS ARE COMPLIANCE WITH EN 60664-1 POLLUTION II
- ENVIRONMENT CHARACTERISTICS:
 IP67 IP6K9K RATED (WHEN MATING)
 IP2XB RATED FOR FINGER TOUCH-PROOF

DIMENSIONS ANSI Y14.5M UNITS: MM Pro/E FILE	TOLERANCES .X ±0.3 .XX ±0.10 ANGLES ±0.5°	PROJECTION 	TITLE HVSL5 600 02 2X X XX BOX MOUNTING RECEPTACLE ASSEMBLY		
			Amphenol Pcd Shenzhen ENGR Robin Yuan 24/06/15 CHKD APPD		
ORIGINAL NOT FOR CUSTOMER DISTRIBUTION	THIS DOCUMENT CONTAINS PROPRIETARY INFORMATION WHICH IS THE CONFIDENTIAL PROPERTY OF AMPHENOL PCD SHENZHEN		SIZE A3	DWG NO. C-HVSL5600022XXXX	REV 4
			CODE: 58982	SCALE: 1:1	SHEET 1 OF 2

C-HVSL5600022XXXX

C-HVSL5600022XXXX

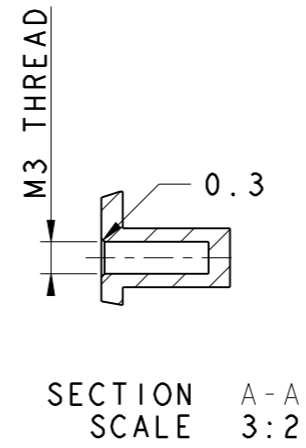
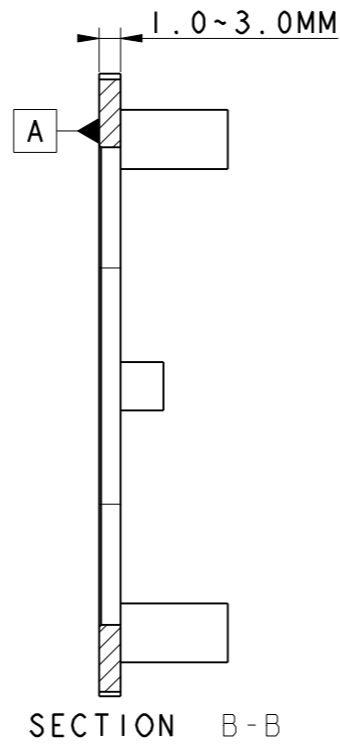
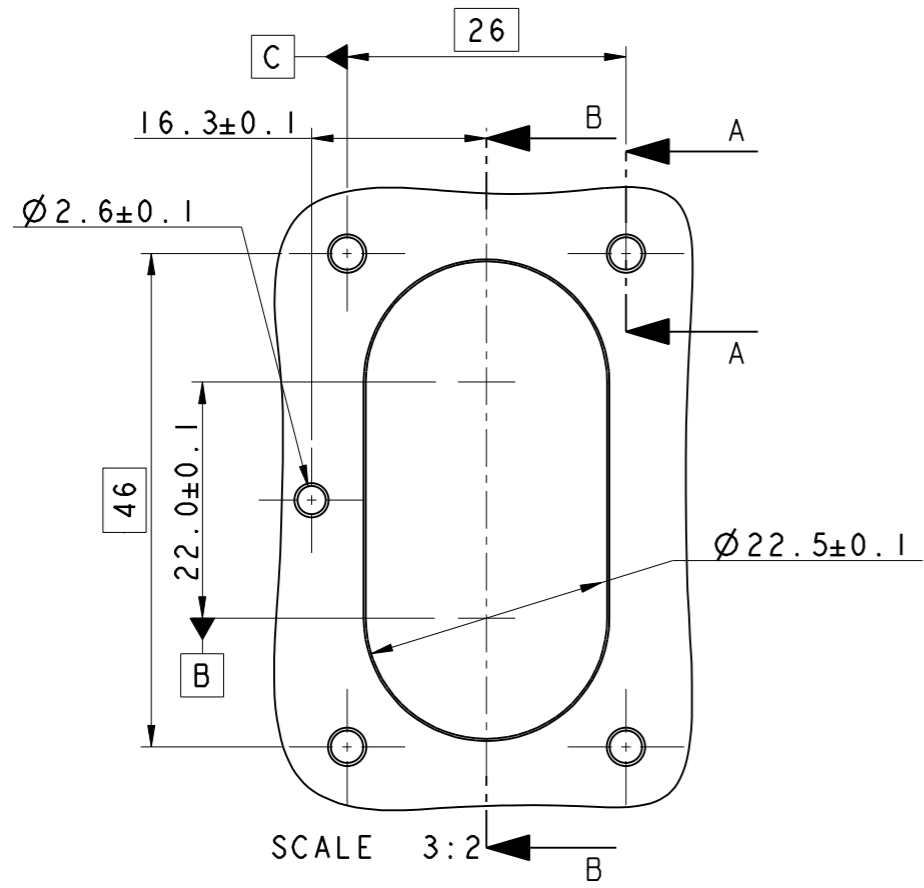

CODING A

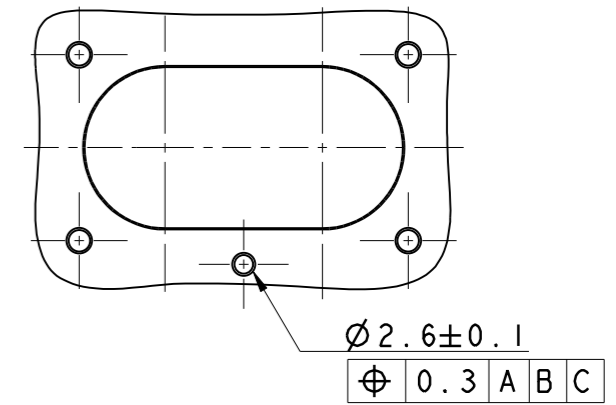

CODING B

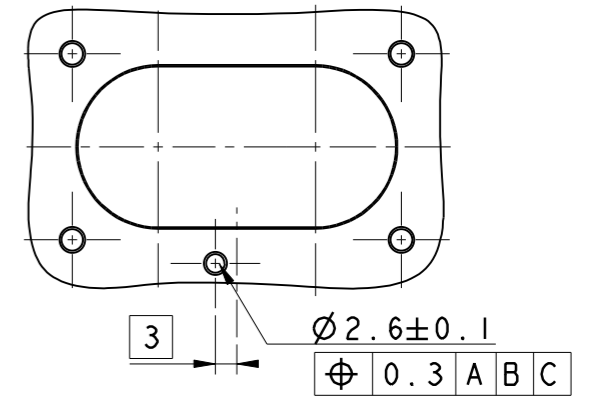

CODING C

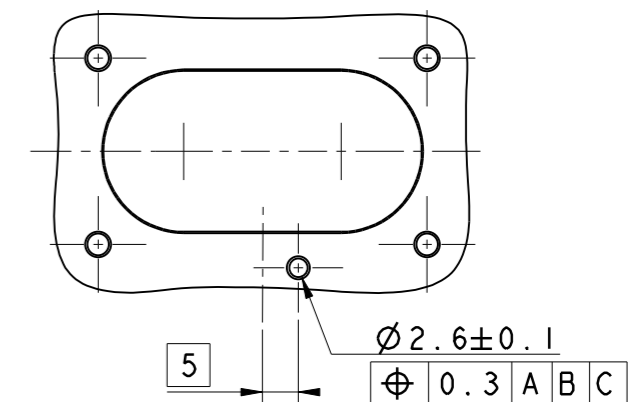

PANEL DRILLING

C-HVSL5600022XXXX

C-HVSL5600022XXXX

SIZE A3	DWG NO. C-HVSL5600022XXXX	REV 4
CODE: 58982	SCALE: 1:1	SHEET 2 OF 2

单击下面可查看定价，库存，交付和生命周期等信息

[>>Amphenol\(安费诺\)](#)