

This document is the property of Amphenol Corporation and is delivered on the express condition that it is not to be disclosed, reproduced or used, in whole or in part, for manufacture or sale by anyone other than Amphenol Corporation without its prior consent, & that no right is granted to disclose or to use any information in this document.

# CUSTOMER DRAWING

## REVISIONS

SYM	ECN	DESCRIPTION	DATE	APPROVED
1	NA	FIRST RELEASE	01/23/19	IP
2	NA	UPDATED DESIGN	05/17/19	IP
3	NA	UPDATED DESIGN	08/16/19	IP

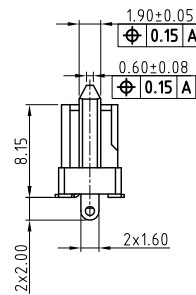
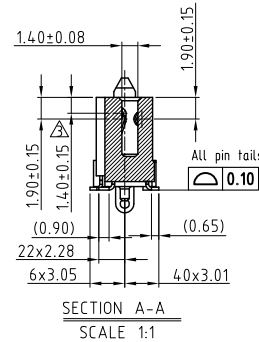
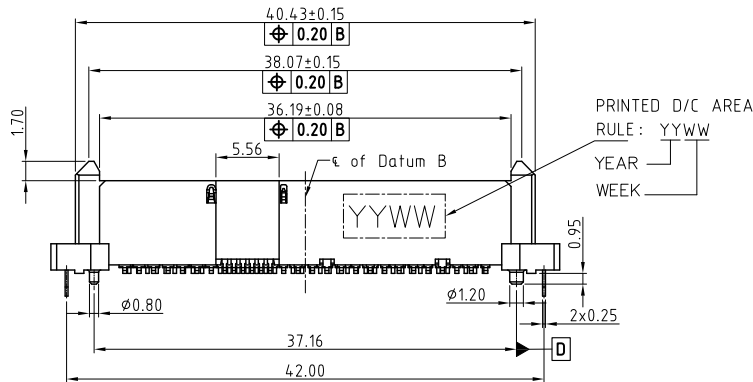
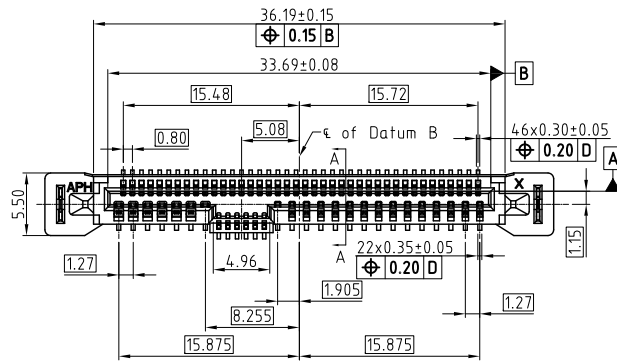
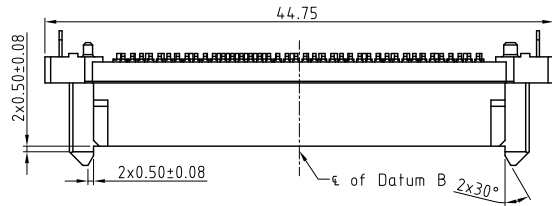

### NOTES

- MATERIAL
  - HOUSING: HIGH TEMPERATURE THERMOPLASTIC, UL94V-0, COLOR:BLACK.
  - CONTACTS : PHOSPHOR BRONZE  
PLATING: REFER TO P/N SYSTEM ON MATING AREA.  
1.27um MIN NICKEL UNDER PLATED OVERALL.  
2.54um MIN PURE MATTE TIN ON SOLDER TAILS.
  - SOLDER CLIPS: COPPER ALLOY  
2.54um MIN PURE MATTE TIN OVER 1.27um MIN NICKEL.
- GENERAL SPECIFICATION
  - CURRENT RATING: 1.5A/PER PIN (POWER SECTION).
  - CONTACT RESISTANCE: 30mΩ MAX (INITIAL).
  - INSULATOR RESISTANCE: 1000MΩ MIN.
  - DIELECTRIC WITHSTANDING VOLTAGE: 500 VAC
  - OPERATION TEMPERATURE: -55°C~+105°C
- PREMATING AT P4 & P12
- SUPPORT PCIe GEN4 AND SAS3.0
- DIMENSIONING SHALL BE INTERPRETED PER ASME Y14.5M 1994.
- MATERIAL SHOULD BE FULFILLED AMPHENOL SPEC.# S-SN-002, FOR HALOGEN FREE PRODUCTS, ALSO NEED TO MEET S-SN-004.
- ORDER P/N SYSTEM: PSAS4F313015XXX

MATING AREA PLATING  
 1- 0.76um MIN Au.  
 2- 0.38um MIN Au.  
 3- Gold FLASH

PACKING STYLE  
 NIL- TRAY  
 TR- TAPE AND REEL



UNLESS OTHERWISE SPECIFIED TOLERANCES		APPROVAL	DATE	Amphenol Amphenol East Asia Limited	
	U.S. METRIC	DRAWN	Jackie Tan		08/16/19
.XX	+/- 0.50	CHECKED	Xiang Wang		08/16/19
.XXX	+/- 0.20	CHECKED			
FRACTIONS +/-	0.15	DRAWING FILE : Drawing\PSAS\PSAS4F313015XXX-3		TITLE PCIe/SAS VERTICAL SMT RECEPTACLE	
ANGLES +/-	3°	REMOVE SHARP EDGES		SIZE DRAWING NO. A3 PSAS4F313015XXX	
FOR MATERIALS AND FINISHES SEE NOTES		ANGLE OF PROJECTION		REV. 3	
DIMENSIONS		U.S. INCHES		SCALE NONE SHEET 1 OF 3	
(METRIC) (MM)		(METRIC) (MM)			



This document is the property of Amphenol Corporation and is delivered on the express condition that it is not to be disclosed, reproduced or used, in whole or in part, for manufacture or sale by anyone other than Amphenol Corporation without its prior consent, & that no right is granted to disclose or to use any information in this document.

# CUSTOMER DRAWING

REVISIONS				
SYM	ECN	DESCRIPTION	DATE	APPROVED
REFER TO SHEET 1				

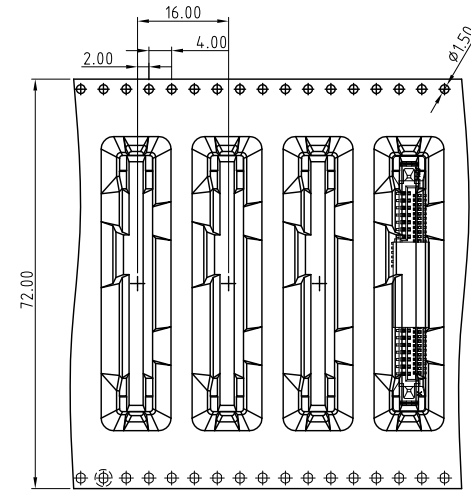

DETAIL A  
SCALE 2:1

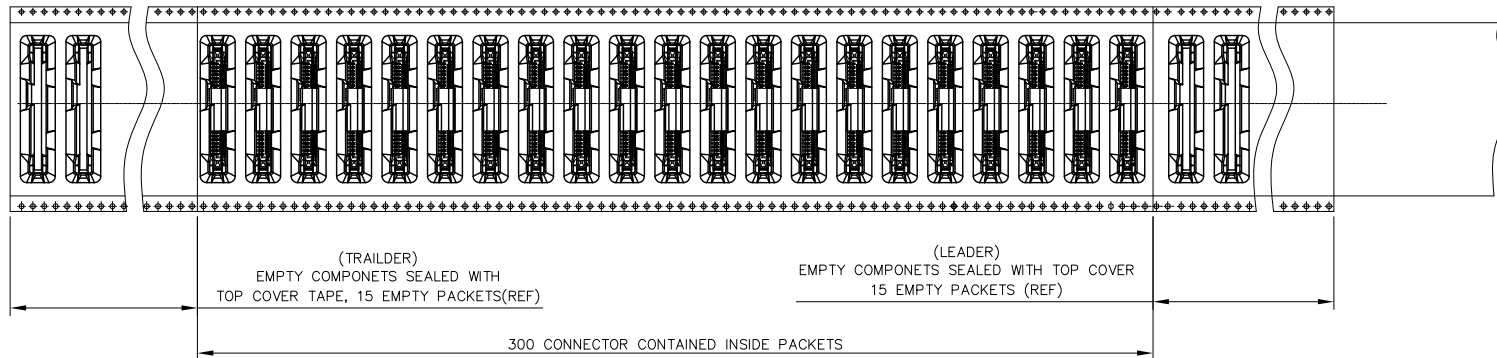
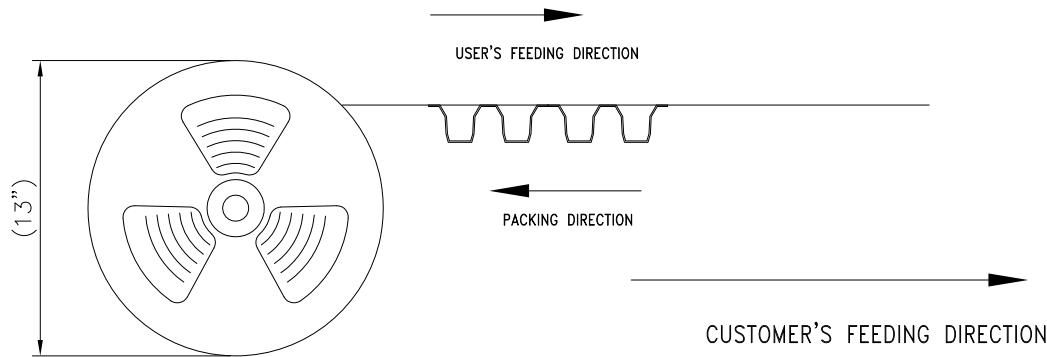

UNLESS OTHERWISE SPECIFIED		APPROVAL	DATE	<b>Amphenol</b> Amphenol East Asia Limited TITLE PCIe/SAS VERTICAL SMT RECEPTACLE
TOLERANCES		DRAWN	08/16/19	
U.S. METRIC		CHECKED	08/16/19	
DRAWING FILE :		CHECKED		
.X +/- 0.50 .XX +/- 0.25 .XXX +/- 0.20 FRACTIONS +/- 3" ANGLES +/-		DRAWING FILE : Drawing\PSAS\PSAS4F313015XXX-3		SIZE
REMOVE SHARP EDGES		ANGLE OF PROJECTION		DRAWING NO.
DIMENSIONS				REV.
U.S. INCHES				A3
(METRIC) (MM)		SCALE	NONE	SHEET 3 OF 3

单击下面可查看定价，库存，交付和生命周期等信息

[>>Amphenol\(安费诺\)](#)