

REVISIONS					
REV	ECO	DESCRIPTION	DATE	BY	APPR
B1	-	RELEASED DRAWING	Nov-23-2014	Ben	Tommy

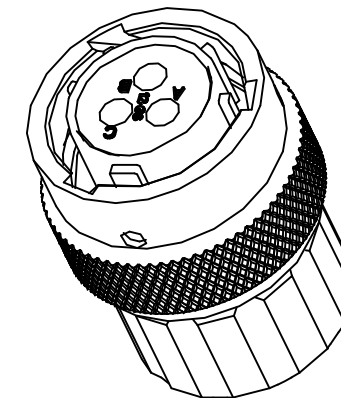
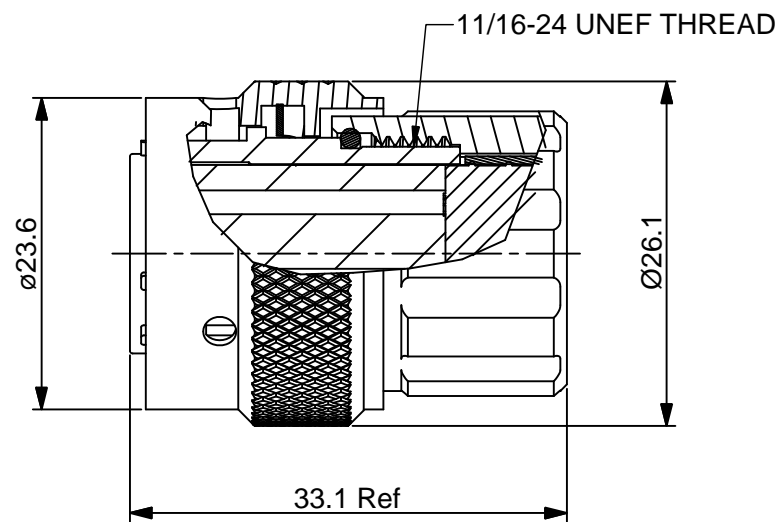
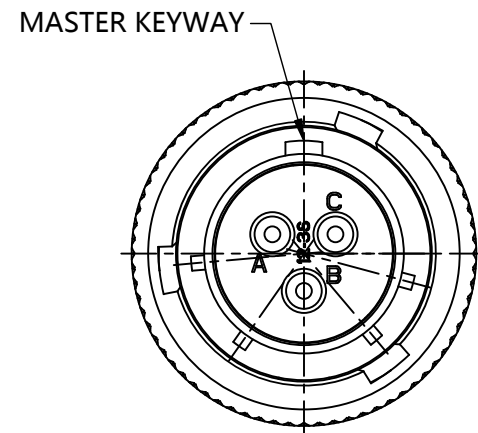

NOTES : (UNLESS OTHERWISE SPECIFIED)

- MATERIAL :
 - SHELL : ZINC ALLOY , NICKEL PLATED.
 - INSERT : THERMOPLASTIC , UL94 V-0.
 - END CAP : THERMOPLASTIC , UL94 V-0.
 - COUPLING NUT : AL ALLOY , NICKEL PLATED.
 - WAVE WASHER : STAINLESS STEEL.
 - O-RING : NBR/SILICONE RUBBER.
 - WIRE SEAL : SILICONE RUBBER.
 - PLASTIC BUSHING : THERMOPLASTIC , UL94 V-0.
- SPECIFICATIONS :
 - RATED CURRENT : 13A (MAX).
 - RATED VOLTAGE : 300V (AC/DC) .
 - OPERATING TEMPERATURE : SEE CHART.
 - DIELECTRIC WITHSTANDING VOLTAGE : LESS THAN 2 MILLIAMPS CURRENT LEAKAGE@2000 VOLTS AC.
 - INSULATION RESISTANCE : 5000 MEGOHMS MIN.
 - IP--CLASS : IP67.
 - MATING CYCLES DURABILITY : 500 CYCLES(MIN).
 - ROHS COMPLIANT.
- SUITABLE CONTACTS : 16# CONTACTS.
- ALL DIMENSIONS ARE FOR REFERENCE USE ONLY.
- CONTACT SIZE AND REAR SEAL WIRE RANGE :

CONTACT SIZE	MIN. INSUL O.D.	MAX. INSUL O.D.	WIRE RANGE
16#	Ø2.0mm	Ø3.2mm	14 - 24AWG

KEY POS	PART NUMBER	
	-40°C ~ 105°C	-40°C ~ 125°C
N	RT06123SNHEC	RT06123SNHEC03
W	RT06123SWHEC	RT06123SWHEC03
X	RT06123SXHEC	RT06123SXHEC03
Y	RT06123SYHEC	RT06123SYHEC03
Z	RT06123SZHEC	RT06123SZHEC03

QUANTITY	SEE PART NUMBER CHART PART NUMBER	DESCRIPTION	ITEM
MATERIALS LIST			
UNLESS OTHERWISE SPECIFIED 1) All dimensions are in metric(mm). 2) Tolerances are as follows: 1 PL DEC ±0.30 2 PL DEC ±0.15 3 PL DEC ±0.08 Fractions ±1/64 Angles ±1° 3) Note reference =		SIGNATURES DRAWN: Ben CHECKED: ENGINEER: APPROVAL: DATE Nov-23-2014	Amphenol Sine Systems - www.amphenol-sine.com 44724 Morley Drive Clinton Township, MI 48036
MATERIAL SPECIFICATIONS: PROCESS SPECIFICATIONS: NEXT ASSY:		CUSTOMER: THIS DRAWING IS SUPPLIED FOR INFORMATION ONLY. DESIGN FEATURES, SPECIFICATIONS AND PERFORMANCE DATA SHOWN HEREON ARE THE PROPERTY OF THE AMPHENOL CORPORATION. NO RIGHTS OF REPRODUCTION ARE IMPLIED. ALL DIMENSIONS ARE SUBJECT TO NORMAL MANUFACTURING VARIATIONS.	
SIZE: B TYPE: C- SCALE: NONE		DWG NO.: RT06123S*HEC* REVISION: B1	SHEET 1 OF 1

TITLE: ECO-MATE,PLUG,SIZE 12,3POS,SOCKET,END CAP
 DWG NO.: RT06123S*HEC*
 REV: B1
 SH: 1
 OF: 1

单击下面可查看定价，库存，交付和生命周期等信息

[>>Amphenol\(安费诺\)](#)