

REVISIONS					
REV	ECO	DESCRIPTION	DATE	BY	APPR
A1	-	RELEASE NEW DRAWING	28JUL17	JONY	TOMMY
A2	-	ADD REF P/N & CRIMP TOOL	22/MAR/21	MILO	TOMMY

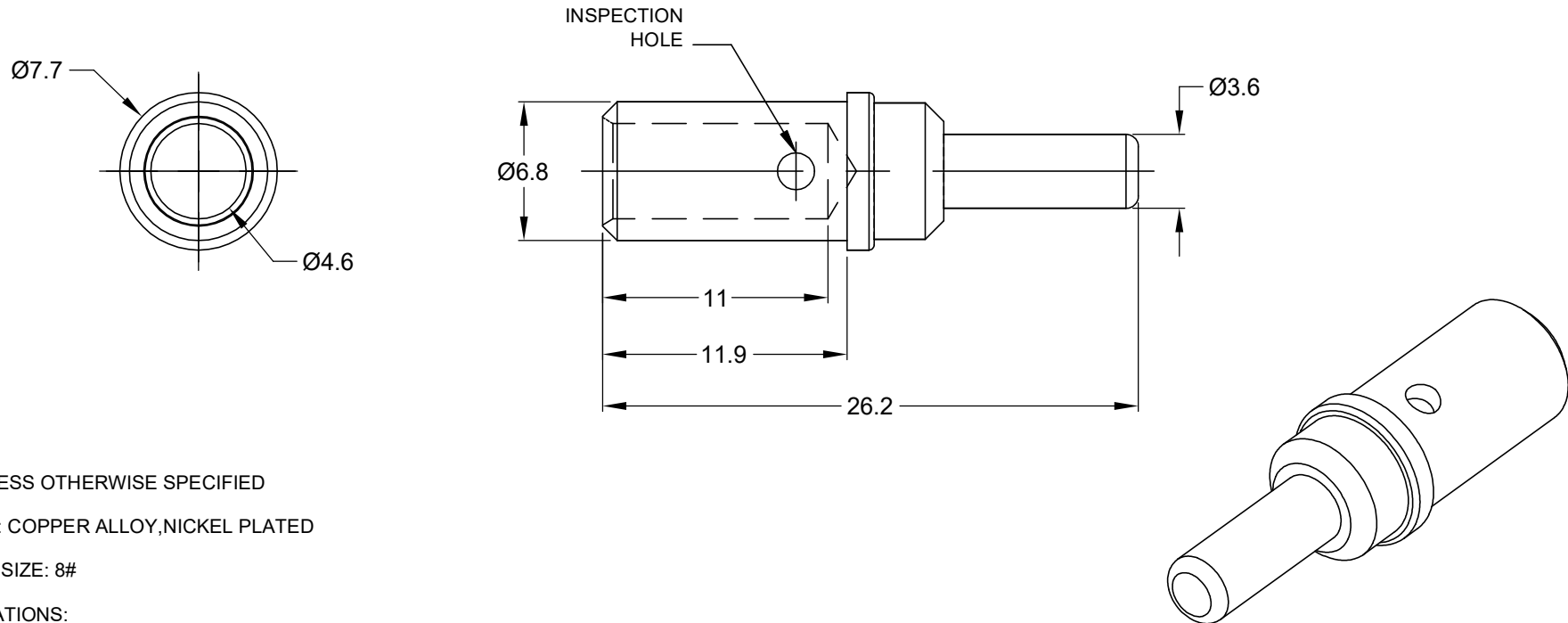

NOTES: UNLESS OTHERWISE SPECIFIED

1. MATERIAL: COPPER ALLOY,NICKEL PLATED
2. CONTACT SIZE: 8#
3. SPECIFICATIONS:
  - 3.1 CURRENT RATING: 60 AMP
  - 3.2 CONTACT MILLIVOLT DROP: 60 MILLIVOLT DROP @ 60 AMP TEST CURRENT.
  - 3.3 ROHS COMPLIANT
4. RECOMMENDED WIRE RANGE: 8 - 10 AWG(8.0-5.0mm<sup>2</sup>)
5. AVAILABLE PNEUMATIC CRIMP TOOL:WA23
6. ALL DIMENSIONS ARE FOR REFERENCE USE ONLY

TITLE: CONTACT PIN, SIZE 8, 8-10 AWG  
DWG NO.: AT60-204-08141  
REV: A2  
SH: 1  
QC: 1

AT60-204-08141		REFERENCE:0460-204-08141	
PART NUMBER		DESCRIPTION	
QUANTITY		ITEM	
<b>MATERIALS LIST</b>			
<b>UNLESS OTHERWISE SPECIFIED</b> 1) All dimensions are in metric(mm). 2) Tolerances are as follows: 1 PL DEC ±0.30 2 PL DEC ±0.15 3 PL DEC ±0.08 Fractions ±1/64 Angles ±1° 3) Note reference =		<b>SIGNATURES</b> DRAWN: MILO DONG 22/MAR/21 CHECKED: ORICALLI 23/MAR/21 ENGINEER: APPROVAL: TOMMY XIE 24/MAR/21 CUSTOMER:	
MATERIAL SPECIFICATIONS:		<h1>Amphenol</h1> <p>Sine Systems - www.amphenol-sine.com 44724 Morley Drive Clinton Township, MI 48036</p>	
PROCESS SPECIFICATIONS:			
NEXT ASSY:		CONTACT PIN, SIZE 8, 8-10 AWG SIZE: B C- TYPE: AT60-204-08141 DWG NO.: REVISION: A2 SCALE: NONE SHEET 1 OF 1	

单击下面可查看定价，库存，交付和生命周期等信息

[>>Amphenol\(安费诺\)](#)