

THIS DRAWING IS SUPPLIED FOR INFORMATION ONLY. DESIGN FEATURES, SPECIFICATIONS AND PERFORMANCE DATA SHOWN HEREON ARE THE PROPERTY OF THE AMPHENOL CORPORATION. NO RIGHTS OF REPRODUCTION ARE IMPLIED. ALL DIMENSIONS ARE SUBJECT TO NORMAL MANUFACTURING VARIATIONS.

Customer Drawing

| REVISIONS | | | | | | |
|-----------|------|-----|---|----------|-----|-------|
| REV | ZONE | ECO | DESCRIPTION | DATE | BY | APPR |
| A | -- | -- | INITIAL RELEASE | 05/21/14 | RW | EC |
| F | -- | -- | Add Dust Cap & Change HVIL Wire, Update Spec. | 03/29/16 | RW | TS |
| H | -- | -- | Add Geometric Tolerance of Flange & Panel | 10/21/16 | RW | PL |
| I | -- | -- | Change Shell and Gasket | 05/10/17 | Sam | Julie |

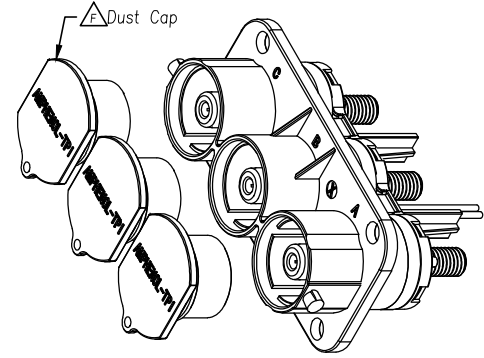
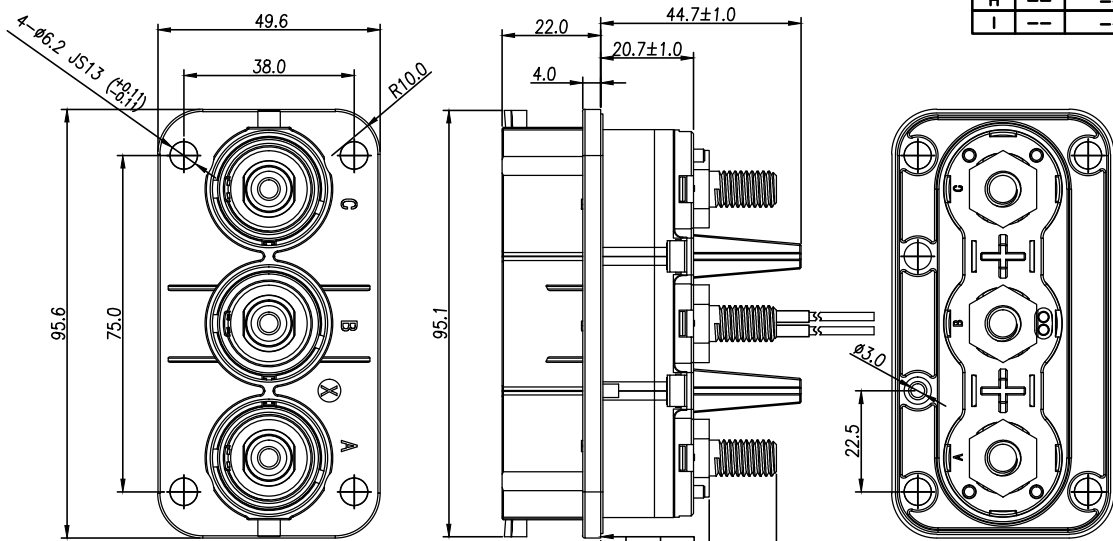

- Notices:
- All non-dimensioned surfaces according to 3D-model & $\sqrt{0.3}$
 - Planeness of panel surface should be less than or equal to 0.1mm
 - Roughness of panel surface should be $\sqrt{1}$ or better.
 - Thickness of panel should not exceed 12mm.

- 规格参数 (Spec.):
- 工作温度 Operating temperature: $-40^{\circ}\text{C} \sim +125^{\circ}\text{C}$.
 - 带高压互锁 Electrical interlock (HVIL).
 - 额定电流 Current rating:
Power: 300A; HVIL: 5A.
 - 额定电压 Operating voltage:
Power: 1000 VDC; Signal: 60 VDC.
 - 耐电压 Dielectric withstanding voltage:
A. 与插头对插后, Pin与铁壳之间
After mating, between pin and metal shell :5000 VDC.
B. 与插头对插后, Pin与HVIL之间
After mating, between pin and HVIL :5000 VDC.
C. 与插头对插后, HVIL与铁壳之间
After mating, between HVIL and metal shell :500 VDC.
D. 与插头对插前, 两个HVIL端子之间耐压
Before mating, between two HVIL terminals :500 VDC.

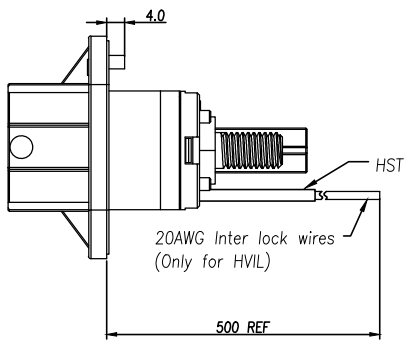
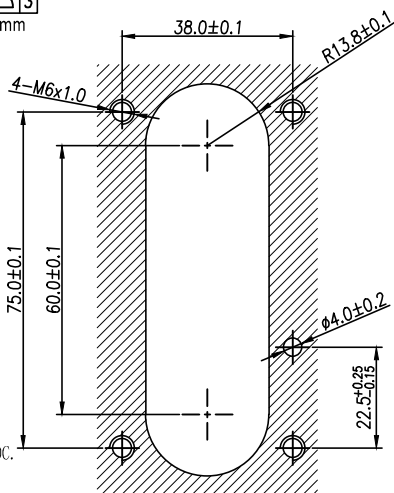

Standard Part List (With HVIL)

| P/N | Model NO. | Mating Plug Model NO. |
|-------------|------------------|------------------------------|
| AC-HA001511 | PL083X-301-20M8 | PL183X-301-XX, PL283X-301-XX |
| AC-HA001512 | PL083Y-301-20M8 | PL183Y-301-XX, PL283Y-301-XX |
| AC-HA002449 | PL083X-301-20M6 | PL183X-301-XX, PL283X-301-XX |
| AC-HA002450 | PL083Y-301-20M6 | PL183Y-301-XX, PL283Y-301-XX |
| AC-HA002531 | PL083X-301-20M10 | PL183X-301-XX, PL283X-301-XX |
| AC-HA002532 | PL083Y-301-20M10 | PL183Y-301-XX, PL283Y-301-XX |

Standard Part List (Without HVIL)

| P/N | Model NO. | Mating Plug Model NO. |
|-------------|------------------|------------------------------|
| AC-HA001513 | PL083X-300-20M8 | PL183X-300-XX, PL283X-300-XX |
| AC-HA001514 | PL083Y-300-20M8 | PL183Y-300-XX, PL283Y-300-XX |
| AC-HA002451 | PL083X-300-20M6 | PL183X-300-XX, PL283X-300-XX |
| AC-HA002452 | PL083Y-300-20M6 | PL183Y-300-XX, PL283Y-300-XX |
| AC-HA002533 | PL083X-300-20M10 | PL183X-300-XX, PL283X-300-XX |
| AC-HA002534 | PL083Y-300-20M10 | PL183Y-300-XX, PL283Y-300-XX |

订购信息 Ordering Information

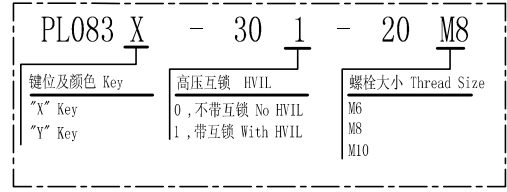

- 铜排推荐安装扭矩 Recommended Fasten Torque on Lug:
M6 : 3.6~4.4 Nm
M8 : 7.2~8.8 Nm
M10: 17.1~20.9 Nm
- 推荐法兰盘螺丝安装扭矩 Recommended Screw Assembly Torque on Flange : 6.2~7.6 Nm

| | | | | | | | |
|--------------|--|--|-------------|--|------------|--|-------------------------|
| | | Amphenol Technical Products International GZ | | | | PART NAME: PwrLok 10mm 3POS Rcpt Conn | |
| | | 第三角投影 THIRD ANGLE PROJECTION | 页面 SHEET | 幅面 SIZE | 版次 REV. | 比例 SCALE | DWG NO: PL083-300-20 |
| 签名 SIGNATURE | | 日期 DATE | | UNLESS OTHERWISE SPECIFIED | | CUST PART #: N/A | |
| 制图 DRAWN | | 05/10/17 | | 1) All dimensions are in metric (mm). 2) Tolerances are as follows: | | CUST REV. - | |
| 审核 CHECKED | | 05/10/17 | | 0 PL DEC ±1.00 1 PL DEC ±0.50 2 PL DEC ±0.20 | | | |
| 批准 APPROVAL | | 05/10/17 | | Angles ±1° | | | |

THIS DRAWING IS SUPPLIED FOR INFORMATION ONLY. DESIGN FEATURES, SPECIFICATIONS AND PERFORMANCE DATA SHOWN HEREON ARE THE PROPERTY OF THE AMPHENOL CORPORATION. NO RIGHTS OF REPRODUCTION ARE IMPLIED. ALL DIMENSIONS ARE SUBJECT TO NORMAL MANUFACTURING VARIATIONS.

Customer Drawing

Amphenol TPI
2018-08-22
REGISTERED COPY

| REVISIONS | | | | | |
|-----------|------|-----|---|----------|-----------|
| REV | ZONE | ECO | DESCRIPTION | DATE | BY APPR |
| A | --- | --- | INITIAL RELEASE | 05/21/14 | RW EC |
| F | --- | --- | Add Dust Cap & Change HVIL Wire, Update Spec. | 03/29/16 | RW TS |
| H | --- | --- | Add Geometric Tolerance of Flange & Panel | 10/21/16 | RW PL |
| I | --- | --- | Change Shell and Gasket | 05/10/17 | Sam Julie |

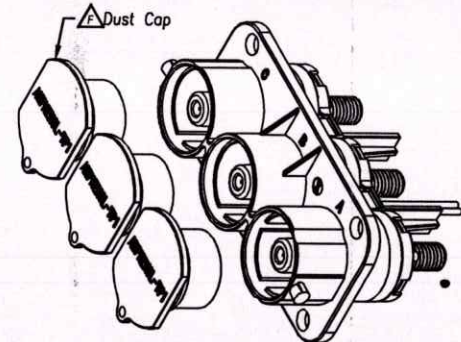
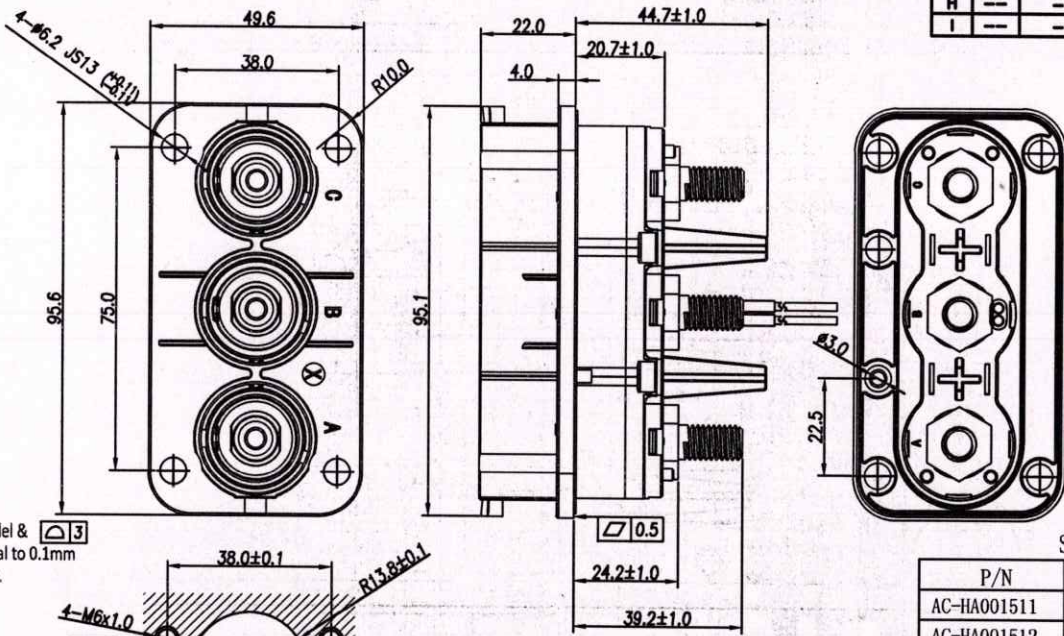

- Notices:
- All non-dimensioned surfaces according to 3D-model & $\nabla 3$
 - Planeness of panel surface should less than or equal to 0.1mm
 - Roughness of panel surface should be $R\sqrt{3}$ or better.
 - Thickness of panel should not exceed 12mm.

- 规格参数 (Spec.):
- 工作温度 Operating temperature: $-40^{\circ}\text{C} \sim +125^{\circ}\text{C}$.
 - 带高压互锁 Electrical interlock (HVIL).
 - 额定电流 Current rating: Power: 300A; HVIL: 5A.
 - 额定电压 Operating voltage: Power: 1000 VDC; Signal: 60 VDC.
 - 耐电压 Dielectric withstanding voltage:
 - 与插头对插后, Pin与铁壳之间 After mating, between pin and metal shell :5000 VDC.
 - 与插头对插后, Pin与HVIL之间 After mating, between pin and HVIL :5000 VDC.
 - 与插头对插后, HVIL与铁壳之间 After mating, between HVIL and metal shell :500 VDC.
 - 与插头对插前, 两个HVIL端子之间耐压 Before mating, between two HVIL terminals :500 VDC.
 - 防护等级 Protection class: IP67 & IP2X.
 - 电磁屏蔽 Shielding.
 - 机械寿命 Mating cycle: 50 Min.
 - 带自动二次锁扣 Automatic secondary lock.
 - 铜排推荐安装扭矩 Recommended Fasten Torque on Lug: M6 : 3.6~4.4 Nm; M8 : 7.2~8.8 Nm; M10: 17.1~20.9 Nm
 - 推荐法兰盘螺丝安装扭矩 Recommended Screw Assembly Torque on Flange : 6.2~7.6 Nm

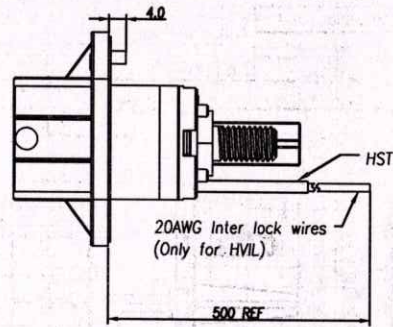
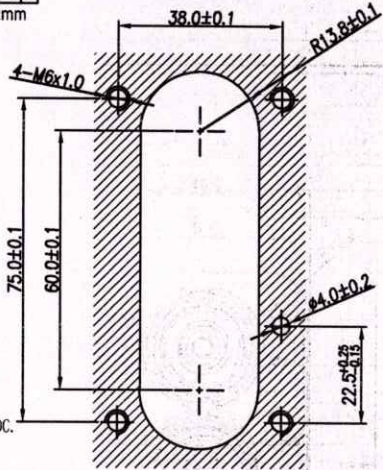

Standard Part List (With HVIL)

| P/N | Model NO. | Mating Plug Model NO. |
|-------------|------------------|------------------------------|
| AC-HA001511 | PL083X-301-20M8 | PL183X-301-XX, PL283X-301-XX |
| AC-HA001512 | PL083Y-301-20M8 | PL183Y-301-XX, PL283Y-301-XX |
| AC-HA002449 | PL083X-301-20M6 | PL183X-301-XX, PL283X-301-XX |
| AC-HA002450 | PL083Y-301-20M6 | PL183Y-301-XX, PL283Y-301-XX |
| AC-HA002531 | PL083X-301-20M10 | PL183X-301-XX, PL283X-301-XX |
| AC-HA002532 | PL083Y-301-20M10 | PL183Y-301-XX, PL283Y-301-XX |

Standard Part List (Without HVIL)

| P/N | Model NO. | Mating Plug Model NO. |
|-------------|------------------|------------------------------|
| AC-HA001513 | PL083X-300-20M8 | PL183X-300-XX, PL283X-300-XX |
| AC-HA001514 | PL083Y-300-20M8 | PL183Y-300-XX, PL283Y-300-XX |
| AC-HA002451 | PL083X-300-20M6 | PL183X-300-XX, PL283X-300-XX |
| AC-HA002452 | PL083Y-300-20M6 | PL183Y-300-XX, PL283Y-300-XX |
| AC-HA002533 | PL083X-300-20M10 | PL183X-300-XX, PL283X-300-XX |
| AC-HA002534 | PL083Y-300-20M10 | PL183Y-300-XX, PL283Y-300-XX |

订购信息 Ordering Information

PL083 X - 30 1 - 20 M8

| | | |
|-----------|------------------|------------------|
| 键位及颜色 Key | 高压互锁 HVIL | 螺栓大小 Thread Size |
| "X" Key | 0, 不带互锁 No HVIL | M6 |
| "Y" Key | 1, 带互锁 With HVIL | MR |
| | | M10 |

AMPHENOL TPI Amphenol Technical Products International GZ

第三角投影 THIRD ANGLE PROJECTION 页面 SHEET 幅面 SIZE 版次 REV. 比例 SCALE PART NAME: PwrLok 10mm 3POS Rept Conn

1 or 1 A3 1

UNLESS OTHERWISE SPECIFIED:
1) All dimensions are in metric (mm).
2) Tolerances are as follows:
0 PL DEC ±1.00
1 PL DEC ±0.50
2 PL DEC ±0.30 Angles ±1°

日期 DATE: 05/10/17
制图 DRAWN: Sam
审核 CHECKED: Jia
批准 APPROVAL: Wu

图号: PL083-300-20
客户零件号: N/A

Fred 520882 2018.8.21

单击下面可查看定价，库存，交付和生命周期等信息

[>>Amphenol\(安费诺\)](#)