

61083- AA B C D E G W V FF

AA	NO. OF POSITIONS
02	2X10
04	2X20
06	2X30
08	2X40
10	2X50
12	2X60
14	2X70
16	2X80
18	2X90
20	2X100

NOTE 10

G	DATE CODE
/	STANDARD, NOT PRINT D/C
P	PRINT DATE CODE

W	TRANSPORT CODE
/	NOT MANDATORY
W	FOR OCEAN SHIPPING

V	MANDATORY CODE
/	STANDARD, NOT MANDATORY P/N
C	ONLY FOR DEDICATED CUSTOMER
H	ONLY FOR DEDICATED CUSTOMER
L	ONLY FOR DEDICATED CUSTOMER
V	ONLY FOR DEDICATED CUSTOMER

E	PACKAGING
0	TUBE WITHOUT METAL CAP
2	T&R WITH METAL CAP
9	TUBE WITH METAL CAP
6	T&R WITH KAPTON TAPE
7	T&R WITH PLASTIC CAP
Q	T&R WITHOUTL CAP

NOTE 10
NOTE 10
NOTE 11
NOTE 10

D	PEG
0	YES
2	NO

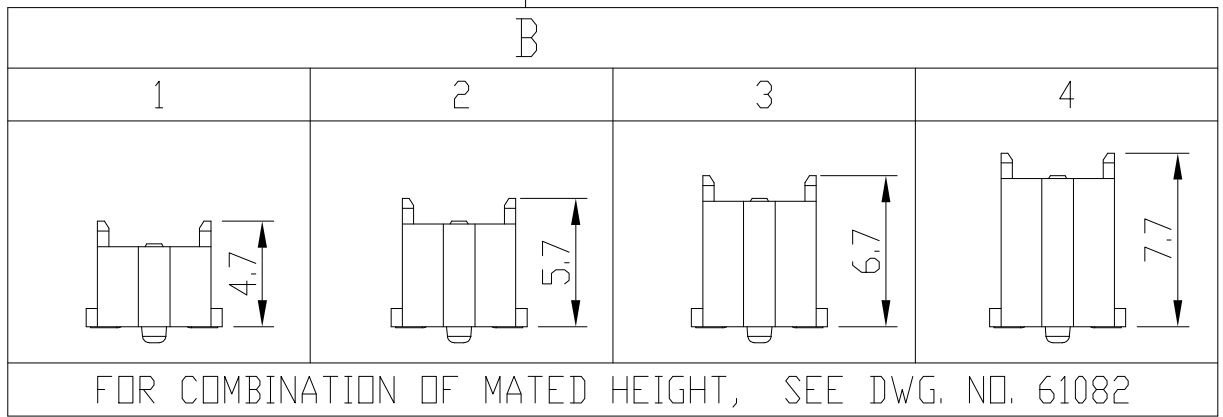

NOTE:

- MATERIAL:
HOUSING: G.F. LCP, NATURAL, UL94-V0
TERMINAL: BRASS
- PLATING: AS SHOWN IN TABLE. NICKEL UNDERPLATE OVERALL 1.27um. MIN.
- SEE GS-12-547 FOR PRODUCT SPEC.
- PACKAGING OPTION 2: NOT ALL SIZES ARE AVAILABLE. CHECK WITH FACTORY.
- THIS PRODUCT MEETS THE EUROPEAN UNION DIRECTIVES AND OTHER COUNTRY REGULATIONS AS DESCRIBED IN GS-22-008.
- THE HOUSING WILL WITHSTAND EXPOSURE UP TO 260~ PEAK TEMPERATURE FOR 30 SECONDS IN A CONVECTION, INFRA-RED OR VAPOR PHASE REFLOW OVEN.
- PLATING OPTION "4" IS LEADFREE ALTERNATIVE FOR OPTION "D", AND OPTION "6" IS LEADFREE ALTERNATIVE FOR OPTION "1".
- HIGH PRECISION COPLANARITY IS AVAILABLE FOR 2X80 TO 2X100 PDS, ALL HEIGHTS. PLS REFER TO PRINT 10069525.
- THE P/N 61083-***** OR 61083-*****LF NOT PRINT DATE CODE.
THE P/N 61083-*****P OR 61083-*****PLF NEED PRINT DATE CODE.
- POSITION 2X10 TYPE ONLY APPLY TO PLUG 1 AND PLUG 3.
PACKAGING WITH METAL CAP AND PLASTIC CAP DOES NOT APPLY TO 2X10 POSITION.
- KAPTON TAPE ONLY APPLY TO POSITION 2X10~2X20.

C	PLATING ON CONTACT AREA / ON SOLDER TAIL AREA	FF
0	GOLD 0.2um MIN. ON CONTACT AREA / TIN LEAD 2.5um MIN ON SOLDER TAIL	NONE
1	GOLD FLASH (0.065um MIN) OVER PALLADIUM-NICKEL 0.69um MIN ON CONTACT AREA / TIN LEAD 2.5um MIN ON SOLDER TAIL	NONE
4	GOLD 0.2um MIN ON CONTACT AREA / MATT TIN 2.5um MIN ON SOLDER TAIL	LF
5	GOLD 0.38um MIN ON CONTACT AREA / MATT TIN 2.5um MIN ON SOLDER TAIL	LF
6	GOLD FLASH 0.065um MIN OVER PALLADIUM-NICKEL 0.69um MIN ON CONTACT AREA / MATT TIN 2.5um MIN ON SOLDER TAIL	LF
7	GOLD 0.76um MIN ON CONTACT AREA / MATT TIN 2.5um MIN ON SOLDER TAIL	LF
9	GOLD 0.2um MIN ON CONTACT AREA / GOLD 0.05um MIN ON SOLDER TAIL	LF
B	GOLD 1.27um MIN ON CONTACT AREA / GOLD 0.05~0.25um ON SOLDER TAIL	LF
C	GOLD 1.27um MIN ON CONTACT AREA / MATT TIN 2.5um MIN ON SOLDER TAIL	LF
D	GOLD 0.38um MIN ON CONTACT AREA / GOLD FLASH ON SOLDER TAIL	LF

mat'l. code		surface		tolerance		projection		product family	
ltr	ecn no	dr	date	ISO 1302	ISO 406	ISO 1101	mm	BERGSTAK HPL545	
AP	ELX-N-33922	Bob	2019-07-05	angles	.0±.2	mm	mm	title	
AR	ELX-N-34967	Bob	2019-09-26	linear	.00±.15	mm	mm	PLUG ASSY	
AS	ELX-N-35593	Bob	2020-01-10	0°±3°	.000±.10	mm	mm	BERGSTAK 0.8MM	
AT	ELX-N-37512	Bob	2020-06-28	dr		scale 1:1	mm	dwg no	sheet 1 of 6
AU	ELX-N-49334	Alan	2023-12-18	engr	Alan Ni		mm	61083	size A3
AM	ELX-N-30296	Bob	2018-05-28	chr	LQ Lei		mm	type Product Customer Drawing	
AN	ELX-N-30741	Bob	2018-11-22	appd	Tim Yao		mm		
sheet	revision	AL	AM	AN	AP	AR	AS	AT	AU
index	sheet	1~6	1~6	1~6	1	1	1	1	1

PRODUCT NO.	NO. OF POSITION	DIMENSION		
		A	B	C
61083-021***	2X10	7.2	13.8	12.2
61083-041***	2X20	15.2	21.8	20.2
61083-061***	2X30	23.2	29.8	28.2
61083-081***	2X40	31.2	37.8	36.2
61083-101***	2X50	39.2	45.8	44.2
61083-121***	2X60	47.2	53.8	52.2
61083-141***	2X70	55.2	61.8	60.2
61083-161***	2X80	63.2	69.8	68.2
61083-181***	2X90	71.2	77.8	76.2
61083-201***	2X100	79.2	85.8	84.2

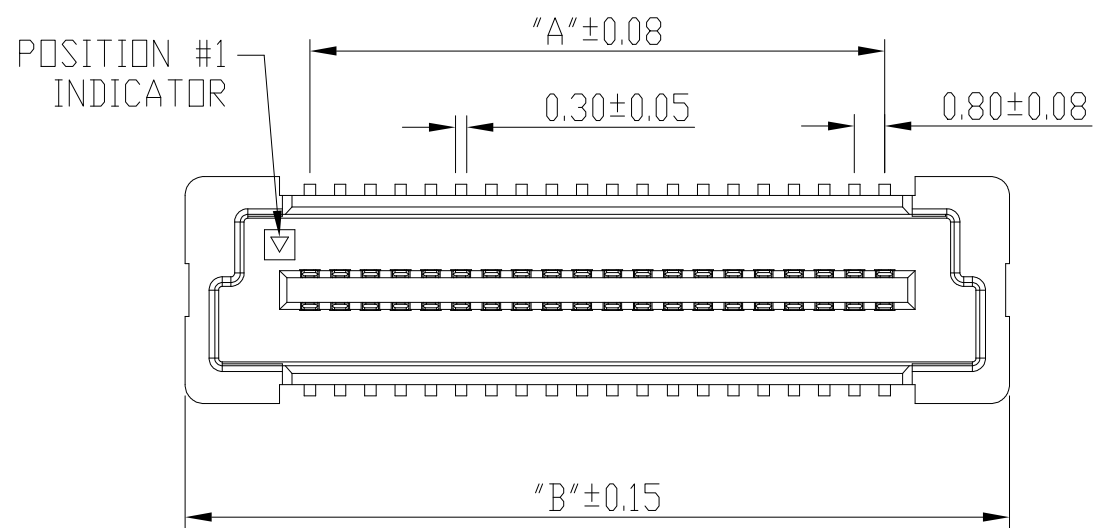
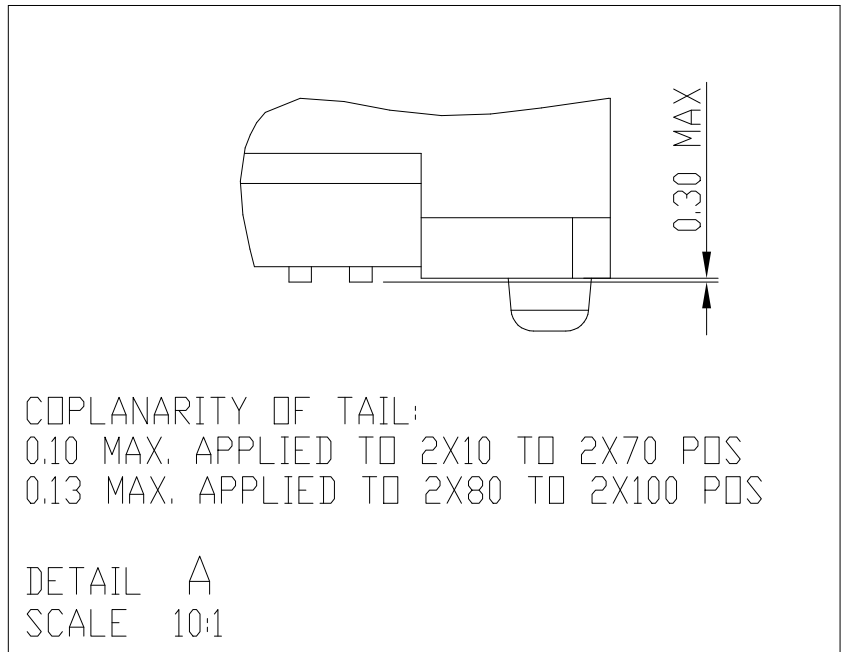
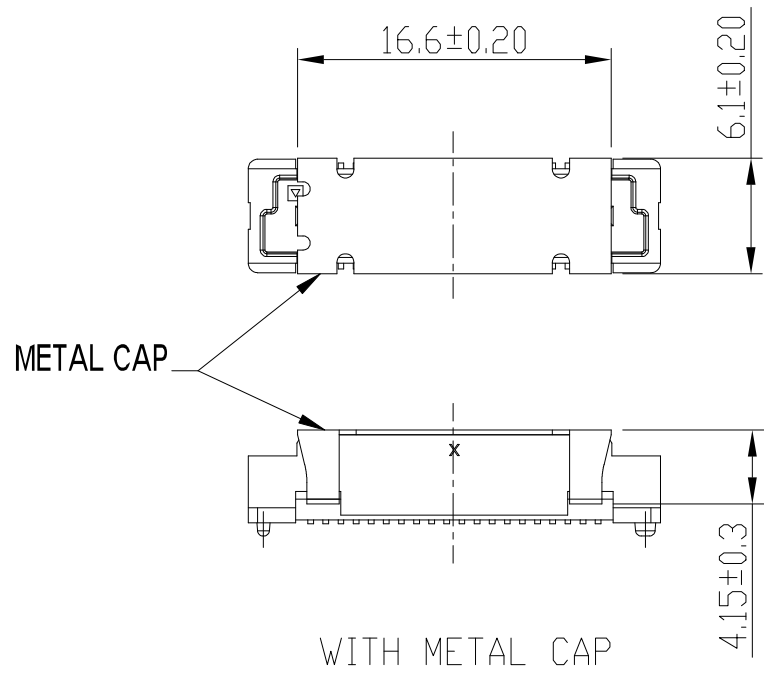

DATE CODE: XXXXXX

- DAY(01~31)
- MONTH(01~12)
- YEAR(00~99)

DETAIL AA

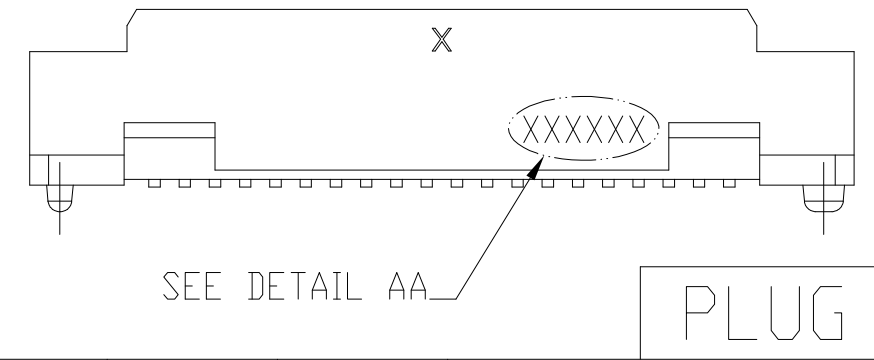
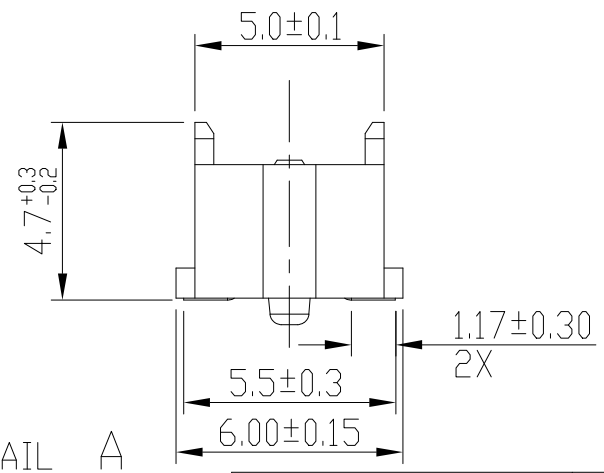
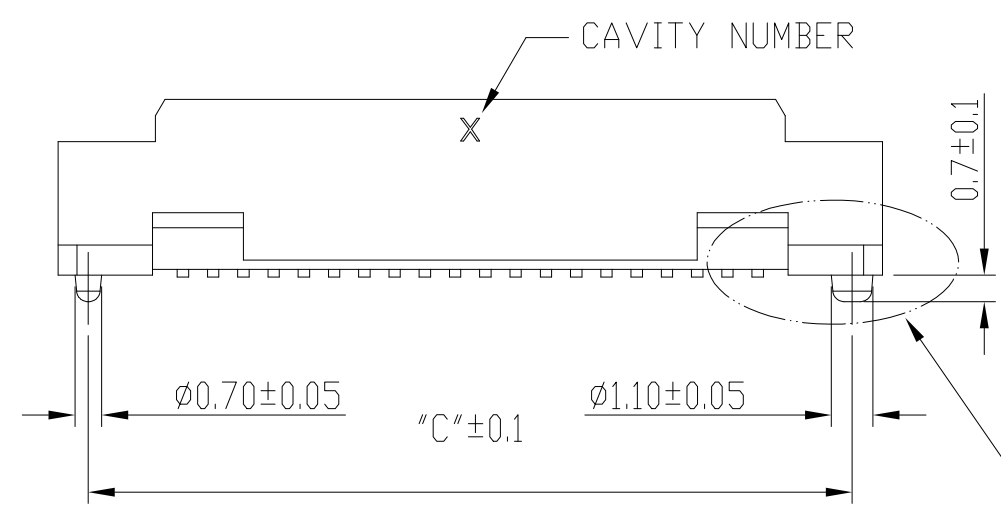

mat'l. code		surface ISO 1302 ✓		tolerance ISO 406 ISO 1101		projection 1101		product family BERGSTAK HPL545	
ltr	ecn no	dr	date	tolerances unless otherwise specified		mm		title	
AU				angles	.0±.2	mm		PLUG ASSY	
				linear	.00±.15	scale 1:1		BERGSTAK 0.8MM	
				0°±3°	.000±.10			dwg no	
				dr	GuoMin Sun	2014-10-21	Amphenol FCI		sheet 2 of 6
				engr	Alan Ni	2023-12-18			size
				chr	LQ Lei	2023-12-18			A3
				appd	Tim Yao	2023-12-18			
sheet index		revision	AU					type	
1		sheet	1					Product Customer Drawing	

© 2016 AFCI
 Amphenol FCI
 © 2016 AFCI

PRODUCT NO.	NO. OF POSITION	DIMENSION		
		A	B	C
61083-042***	2X20	15.2	21.8	20.2
61083-062***	2X30	23.2	29.8	28.2
61083-082***	2X40	31.2	37.8	36.2
61083-102***	2X50	39.2	45.8	44.2
61083-122***	2X60	47.2	53.8	52.2
61083-142***	2X70	55.2	61.8	60.2
61083-162***	2X80	63.2	69.8	68.2
61083-182***	2X90	71.2	77.8	76.2
61083-202***	2X100	79.2	85.8	84.2

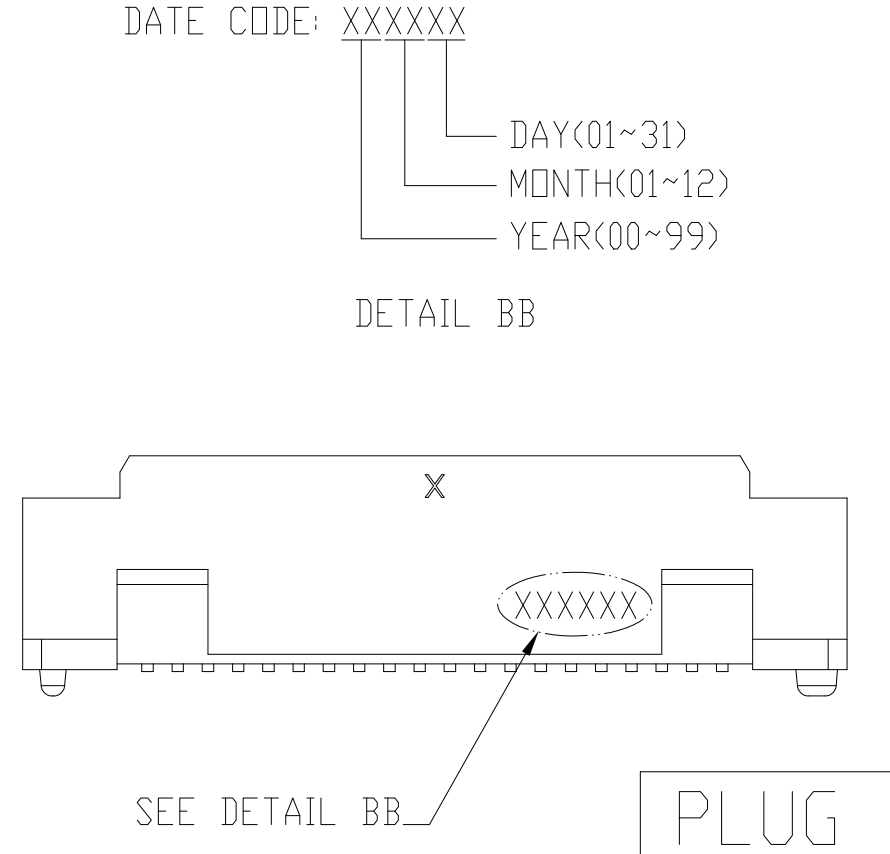
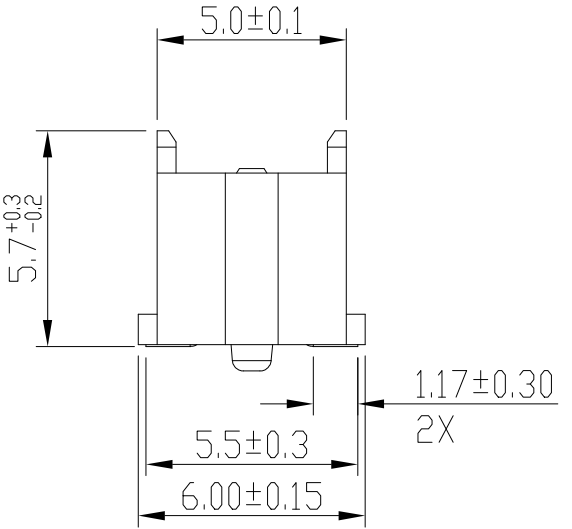
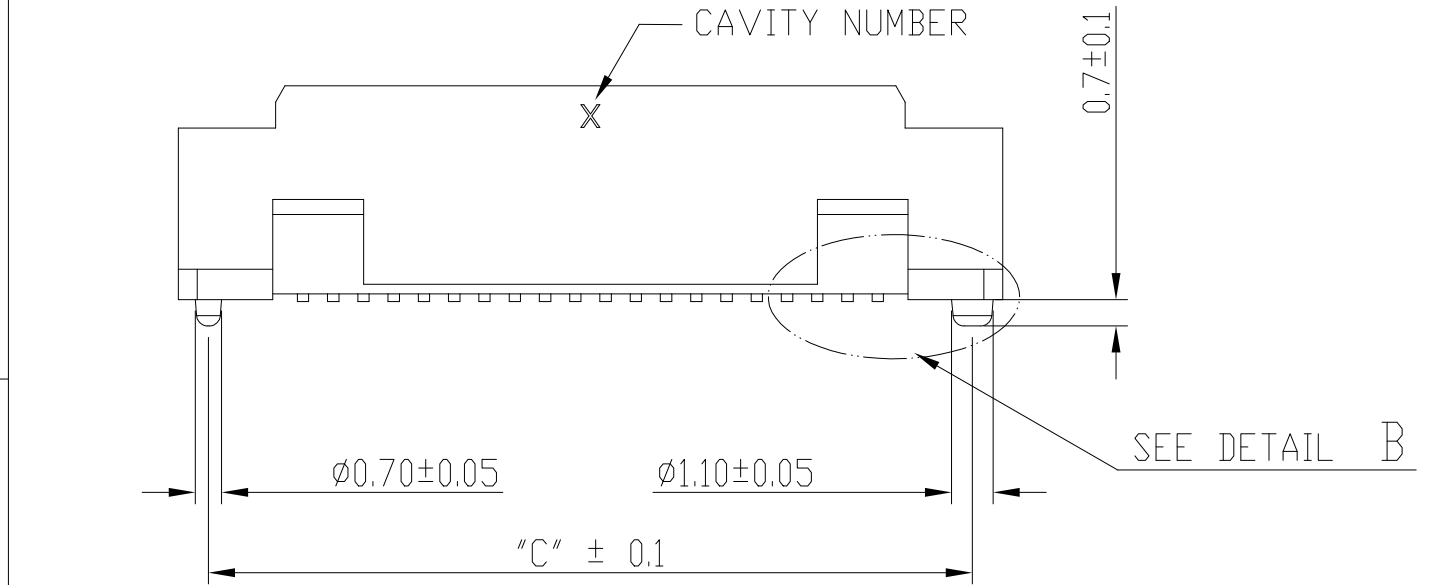
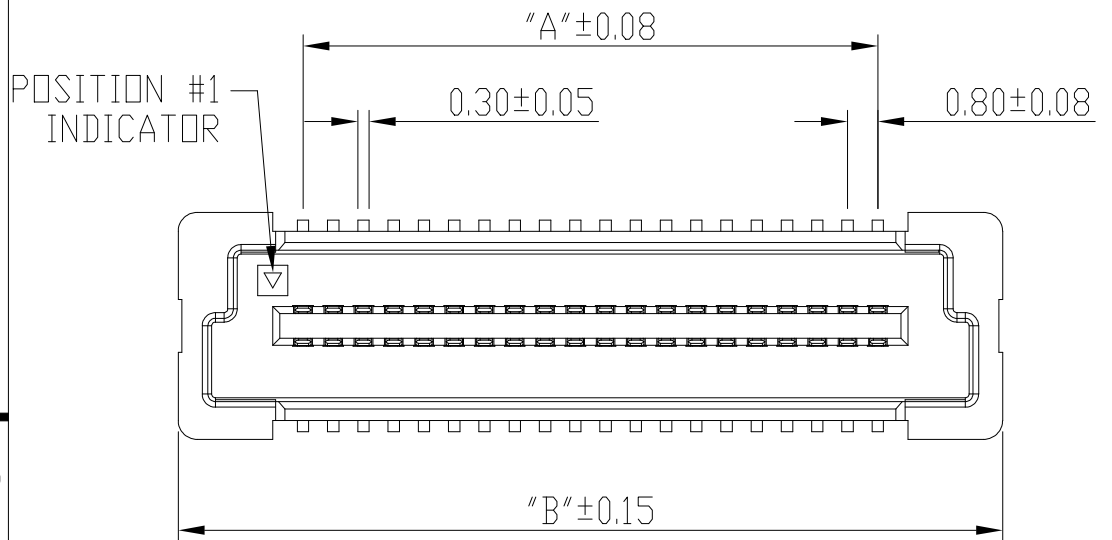
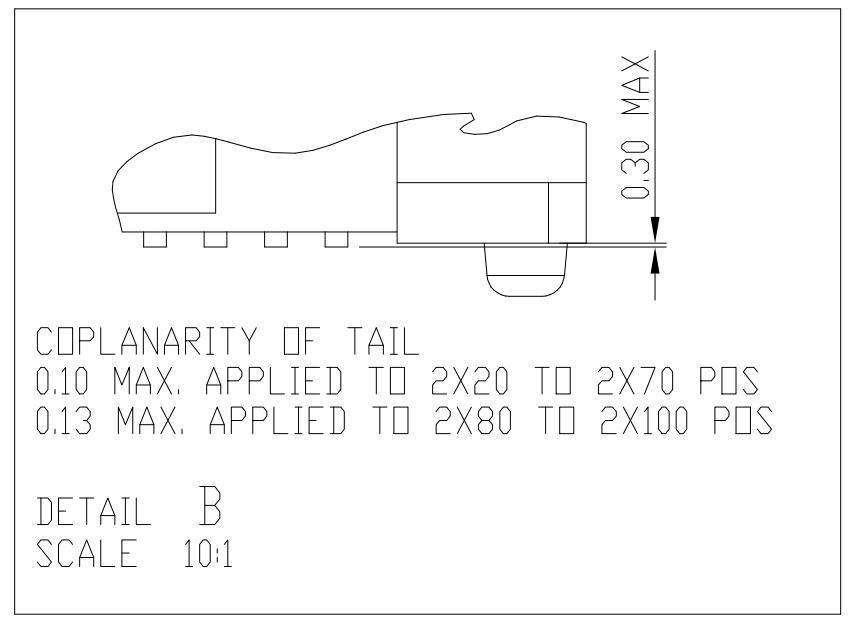
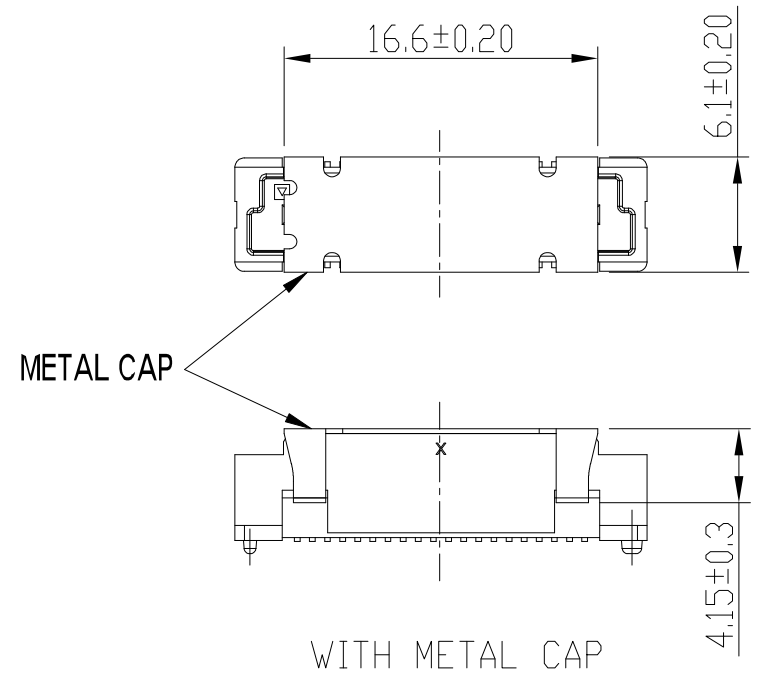

Amphenol FCI

© 2016 AFCI

mat'l. code		surface ISO 1302 ✓		tolerance ISO 406 ISO 1101		projection 1101		product family BERGSTAK HPL545	
ltr		ecn no		dr		date		title	
AU								PLUG ASSY BERGSTAK 0.8MM	
		angles		linear		.0±.2		mm	
		0°±3°				.00±.15		scale 1:1	
		dr		GuoMin Sun		2014-10-21		dwg no sheet 3 of 6 size	
		engr		Alan Ni		2023-12-18		61083 A3	
		chr		LQ Lei		2023-12-18		type Product Customer Drawing	
		appd		Tim Yao		2023-12-18			
sheet index		revision sheet		AU		1			

PRODUCT NO.	NO. OF POSITION	DIMENSION		
		A	B	C
61083-023***	2X10	7.2	13.8	12.2
61083-043***	2X20	15.2	21.8	20.2
61083-063***	2X30	23.2	29.8	28.2
61083-083***	2X40	31.2	37.8	36.2
61083-103***	2X50	39.2	45.8	44.2
61083-123***	2X60	47.2	53.8	52.2
61083-143***	2X70	55.2	61.8	60.2
61083-163***	2X80	63.2	69.8	68.2
61083-183***	2X90	71.2	77.8	76.2
61083-203***	2X100	79.2	85.8	84.2

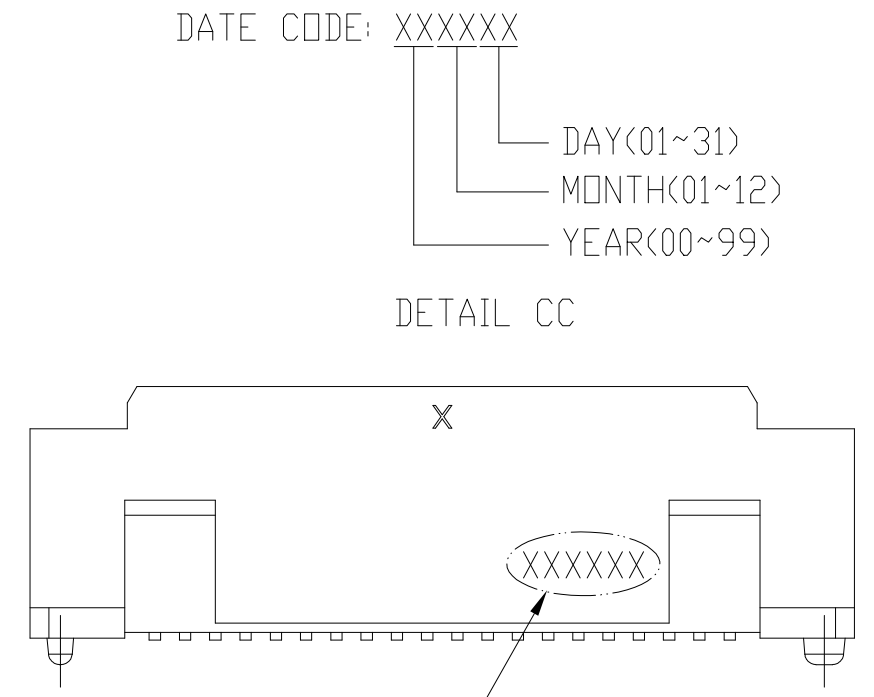
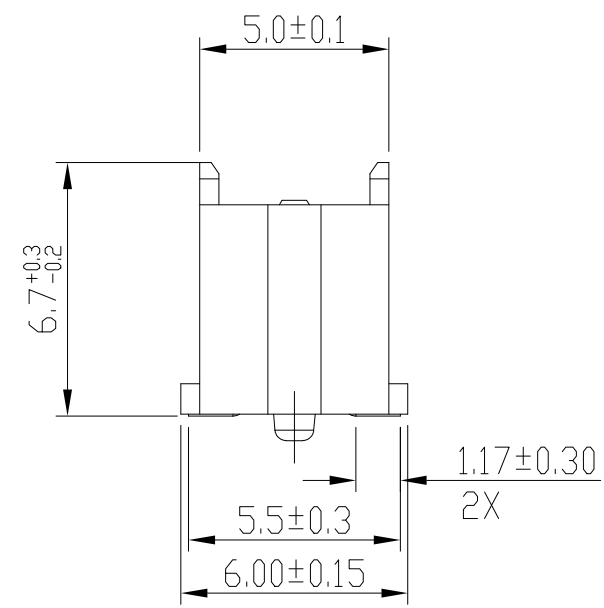
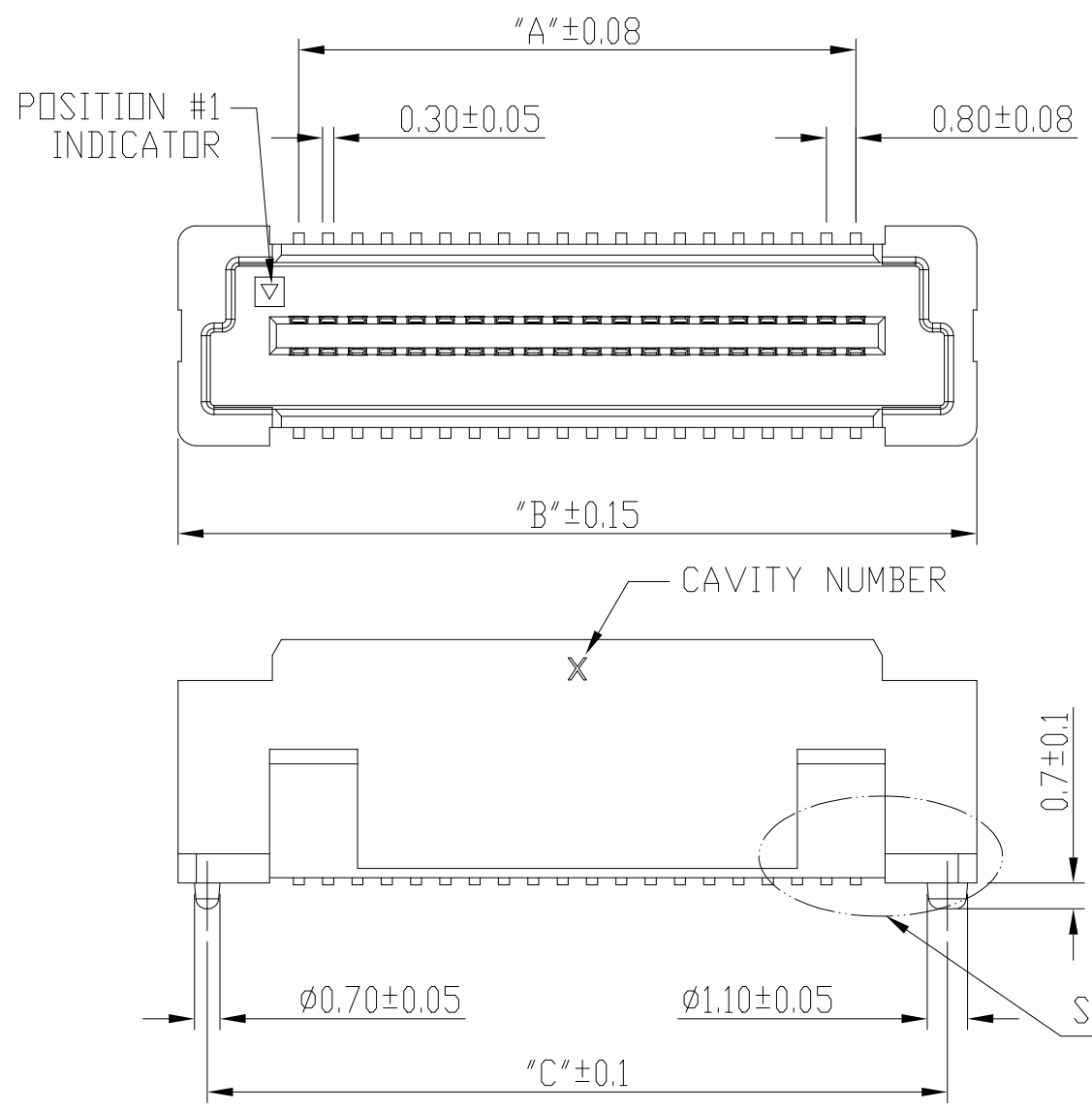
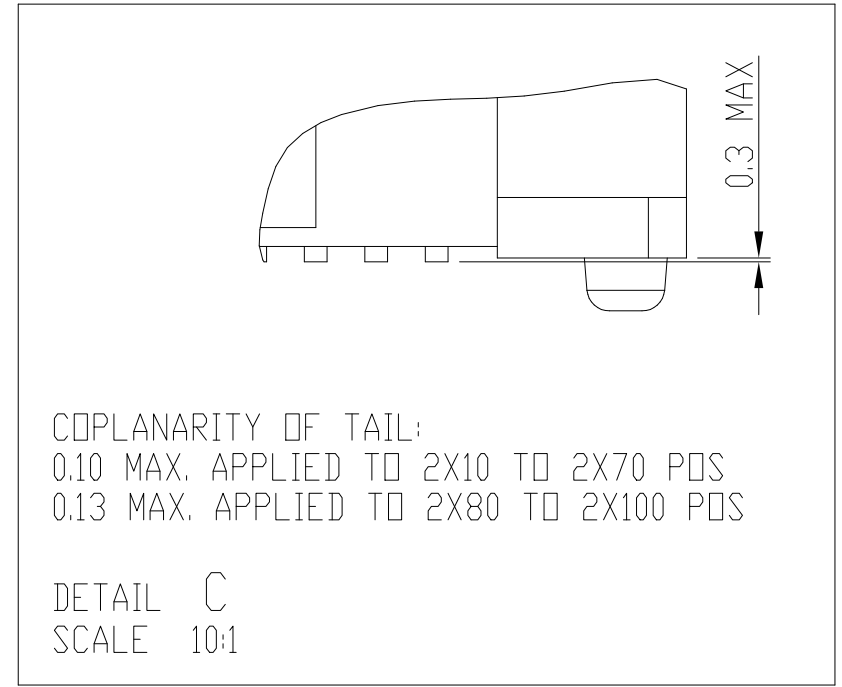
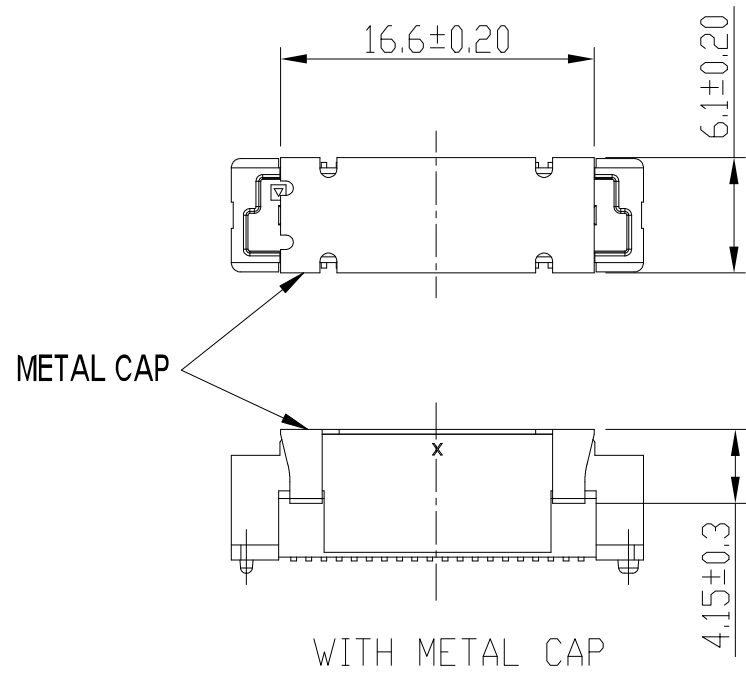

DATE CODE: XXXXXX
 DAY(01~31)
 MONTH(01~12)
 YEAR(00~99)

DETAIL CC

PLUG 3

mat'l. code		surface ISO 1302 ✓		tolerance ISO 406 ISO 1101		projection 1101		product family BERGSTAK HPL545		
ltr	ecn no	dr	date	tolerances unless otherwise specified		mm		title		
AU				angles	.0±.2	scale 1:1		PLUG ASSY BERGSTAK 0.8MM		
				linear	.00±.15			dwg no sheet 4 of 6 size		
				0°±3°	.000±.10			61083 A3		
				dr	GuoMin Sun	2014-10-21	Amphenol FCI		type Product Customer Drawing	
				engr	Alan Ni	2023-12-18				
				chr	LQ Lei	2023-12-18				
				appd	Tim Yao	2023-12-18				
sheet index	revision sheet	AU	1							

Amphenol FCI

© 2016 AFCI

PRODUCT NO.	NO. OF POSITION	DIMENSION		
		A	B	C
61083-044***	2X20	15.2	21.8	20.2
61083-064***	2X30	23.2	29.8	28.2
61083-084***	2X40	31.2	37.8	36.2
61083-104***	2X50	39.2	45.8	44.2
61083-124***	2X60	47.2	53.8	52.2
61083-144***	2X70	55.2	61.8	60.2
61083-164***	2X80	63.2	69.8	68.2
61083-184***	2X90	71.2	77.8	76.2
61083-204***	2X100	79.2	85.8	84.2

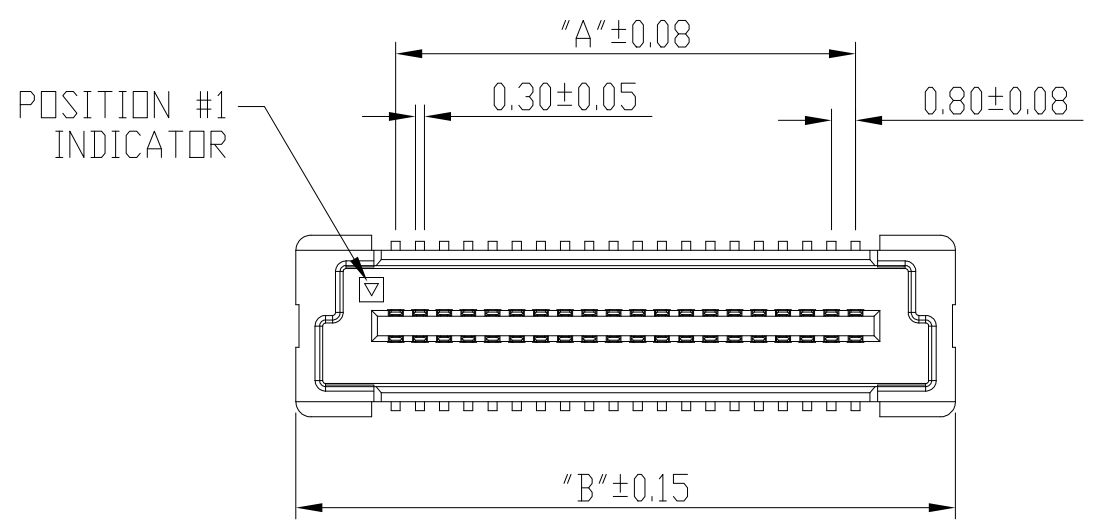
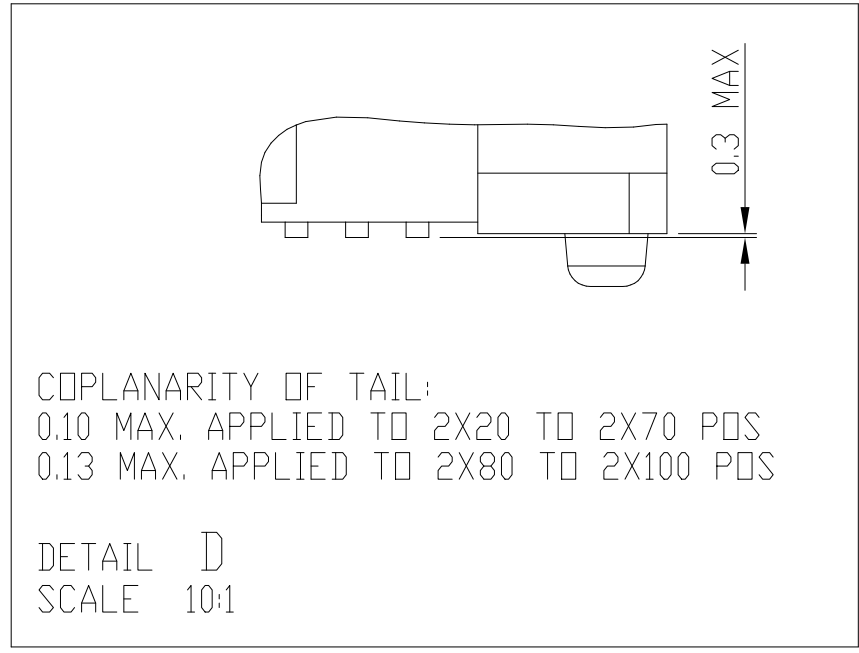
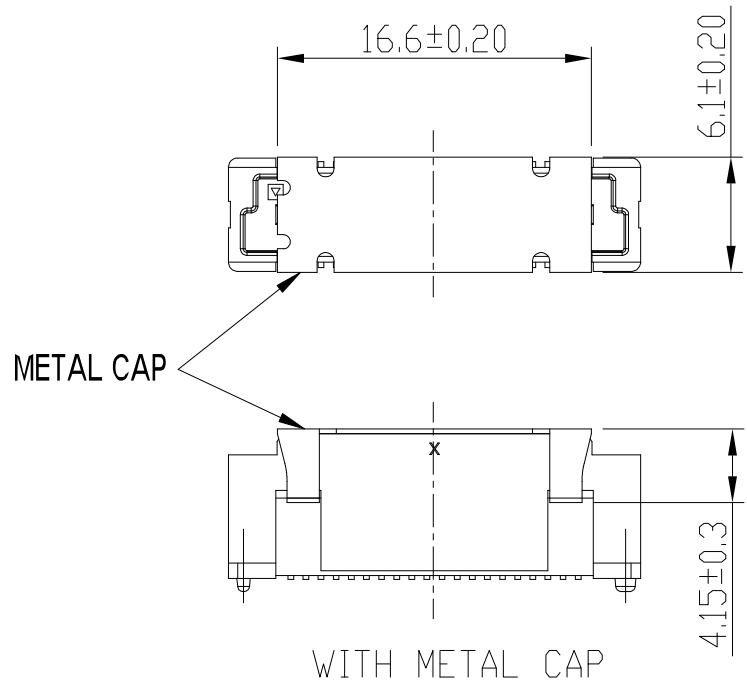

DATE CODE: XXXXXX
 DAY(01~31)
 MONTH(01~12)
 YEAR(00~99)

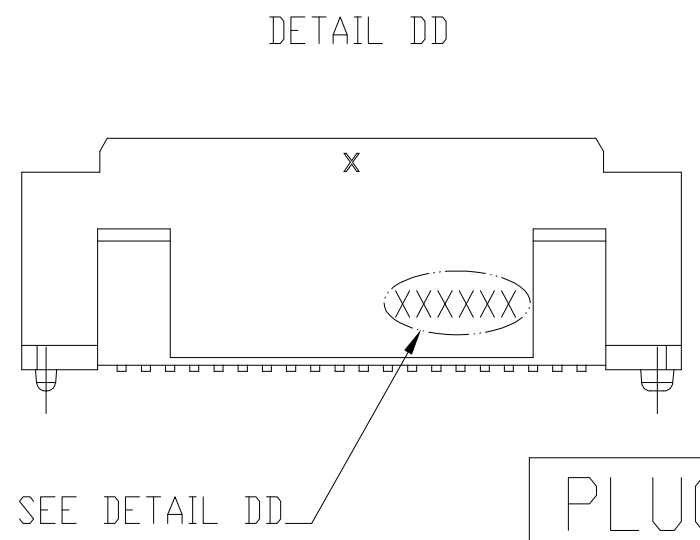
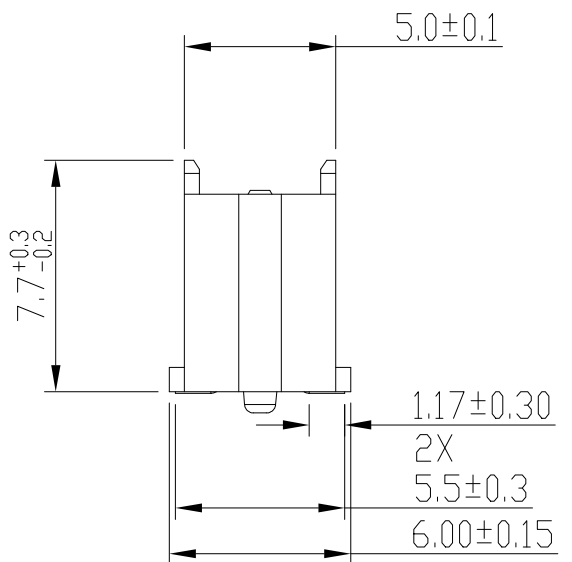
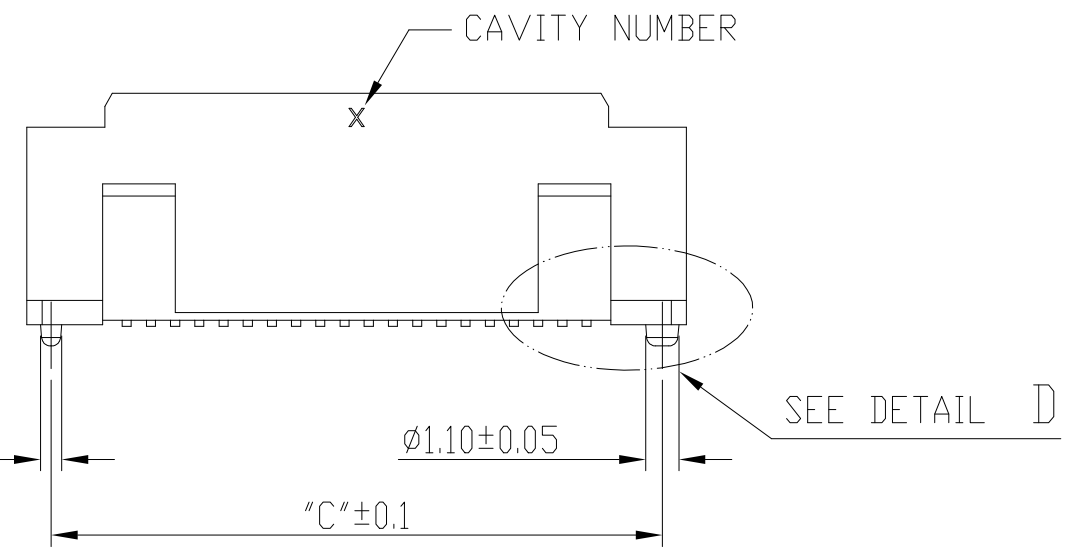

mat'l. code		surface ISO 1302 ✓		tolerance ISO 406 ISO 1101		projection 1101		product family BERGSTAK HPL545	
ltr	ecn no	dr	date	tolerances unless otherwise specified		mm		title	
AU				angles	.0±.2	scale 1:1		PLUG ASSY BERGSTAK 0.8MM	
				linear	.00±.15			dwg no 61083 sheet 5 of 6 size A3	
				0°±3°	.000±.10			type Product Customer Drawing	
				dr	GuoMin Sun	2014-10-21			
				engr	Alan Ni	2023-12-18			
				chr	LQ Lei	2023-12-18			
				appd	Tim Yao	2023-12-18			
sheet index	revision sheet	AU	1						

Amphenol FCI
 © 2016 AFCI
 Downloaded From Oneyac.com

FOR PLUG 1/2/3/4

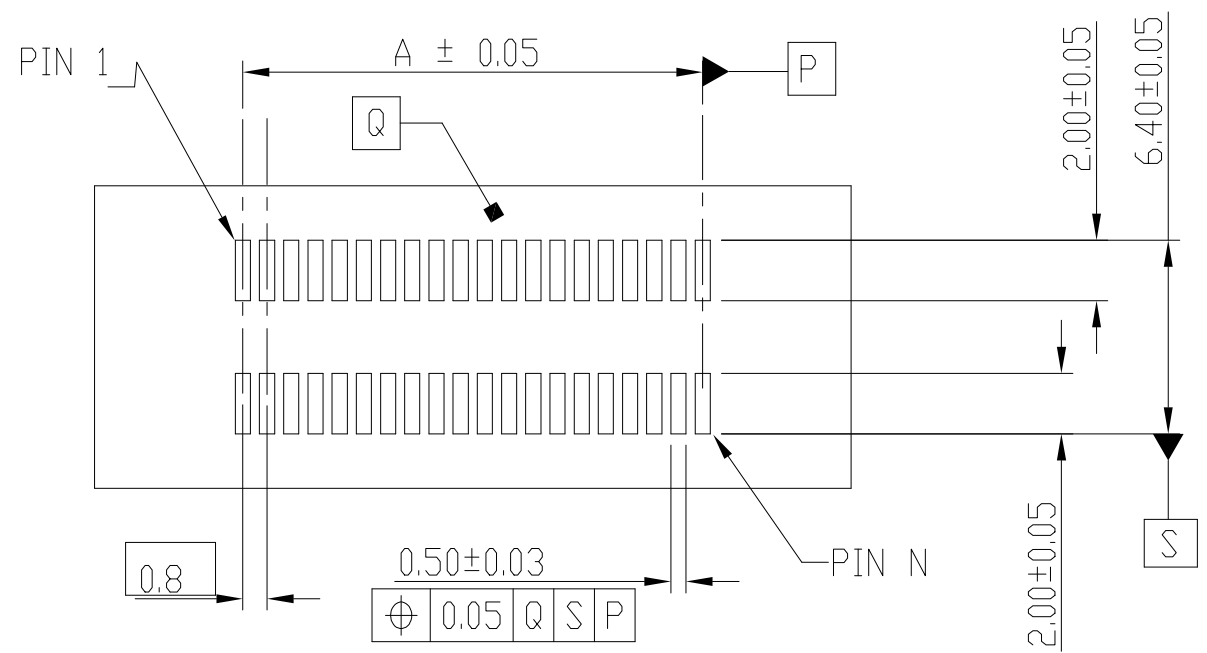

RECOMMENDED PCB LAYOUT WITHOUT PEG FOR
NO. OF POS 2X10, 2X20, 2X30, 2X40, 2X50 2X60

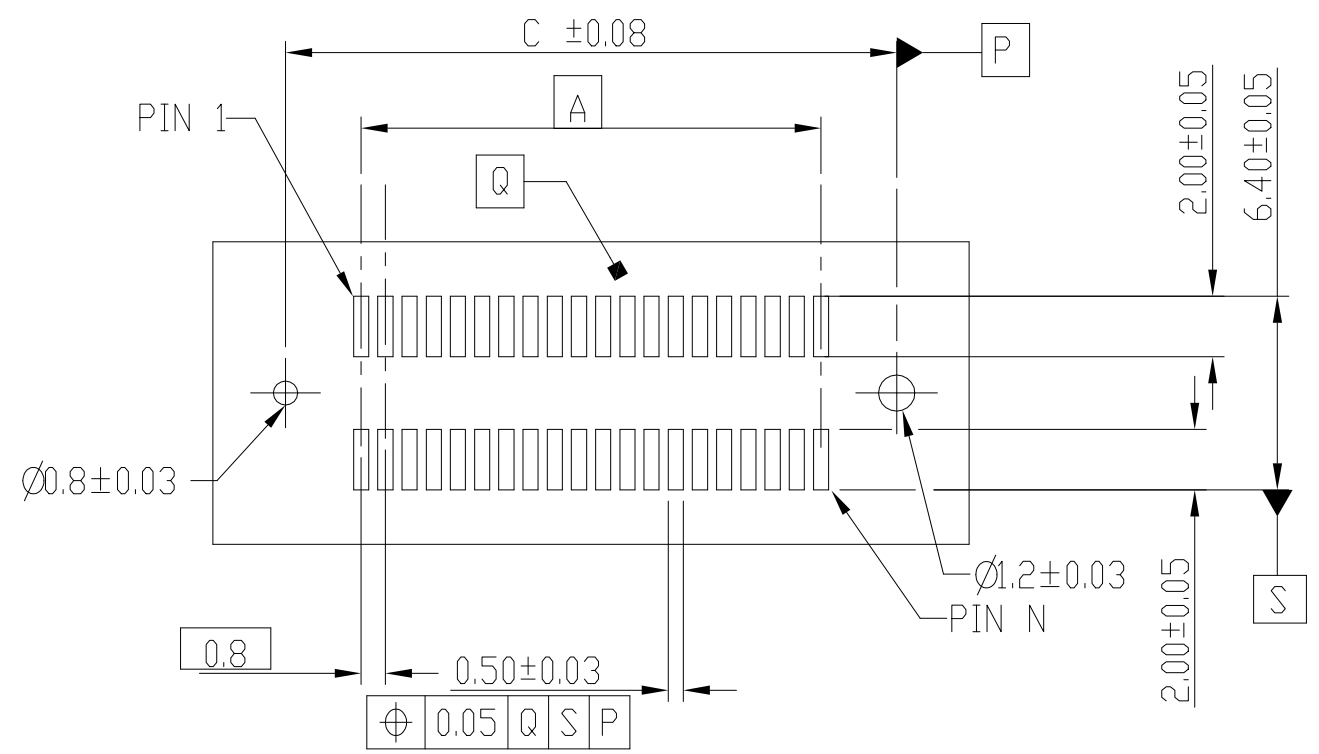

RECOMMENDED PCB LAYOUT WITH PEG FOR
NO. OF POS 2X70, 2X80, 2X90, 2X100

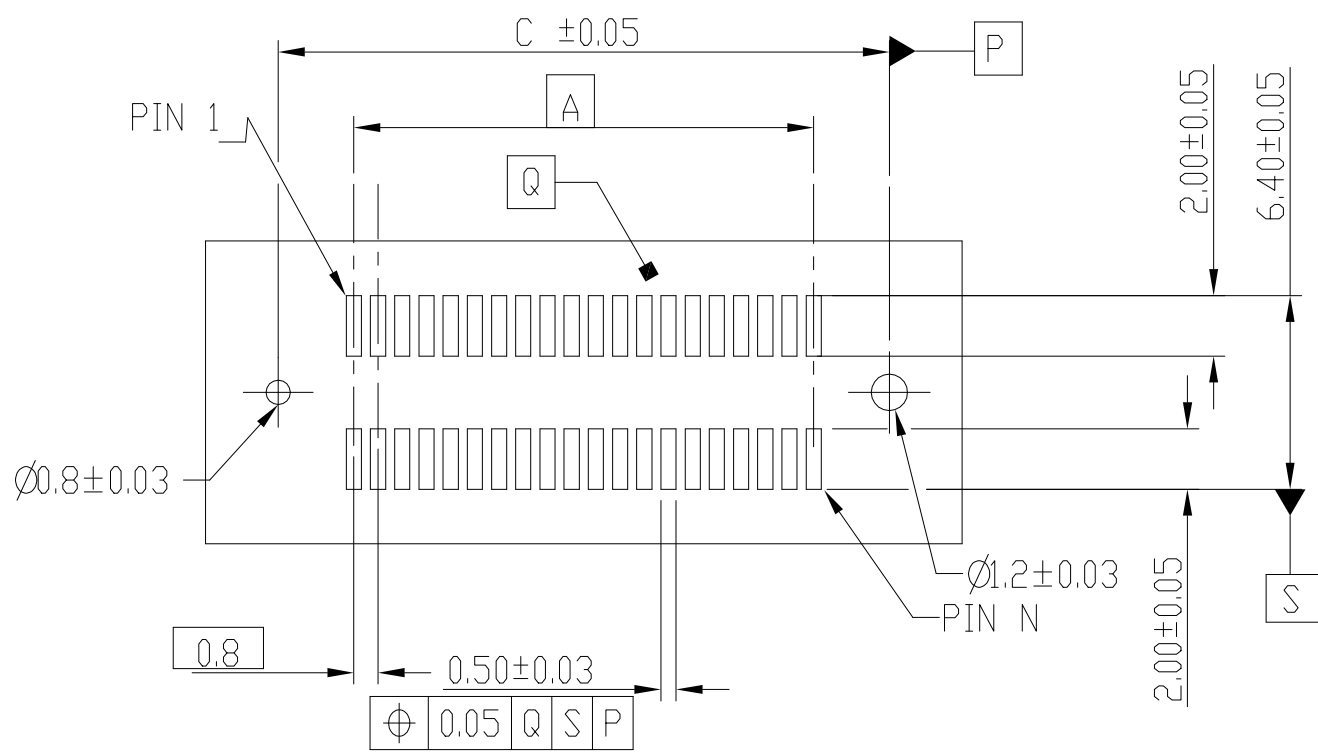

RECOMMENDED PCB LAYOUT WITH PEG FOR
NO. OF POS 2X10, 2X20, 2X30, 2X40, 2X50 2X60

mat'l. code		surface		tolerance		projection		product family	
		ISO 1302 ✓		ISO 406 ISO 1101		mm		BERGSTAK HPL545	
ltr		ecn no		dr		date		title	
AU								PLUG ASSY BERGSTAK 0.8MM	
		angles		linear		scale 1:1		dwg no	
		0°±3'		.0±.2 .00±.15 .000±.10		Amphenol FCi		sheet 6 of 6 size	
		dr		GuoMin Sun		2014-10-21		61083	
		enr		Alan Ni		2023-12-18		A3	
		chr		LQ Lei		2023-12-18		type	
		appd		Tim Yao		2023-12-18		Product Customer Drawing	
sheet index		revision sheet		AU		1			

Amphenol
FCi

© 2016 AFCI

单击下面可查看定价，库存，交付和生命周期等信息

[>>Amphenol\(安费诺\)](#)