

THIS DRAWING IS SUPPLIED FOR INFORMATION ONLY. DESIGN FEATURES, SPECIFICATIONS AND PERFORMANCE DATA SHOWN HEREON ARE THE PROPERTY OF THE AMPHENOL CORPORATION. NO RIGHTS OF REPRODUCTION ARE IMPLIED. ALL DIMENSIONS ARE SUBJECT TO NORMAL MANUFACTURING VARIATIONS.

Customer Drawing

REVISIONS					
REV	ZONE	ECO	DESCRIPTION	DATE	BY APPR
A	--	--	Add fasten torque on lug and flange	08/14/15	RW TS
B	--	--	Change HVIL Wire, Update Spec.	03/31/16	RW TS
C	--	--	Increase the model	05/09/16	KC GX

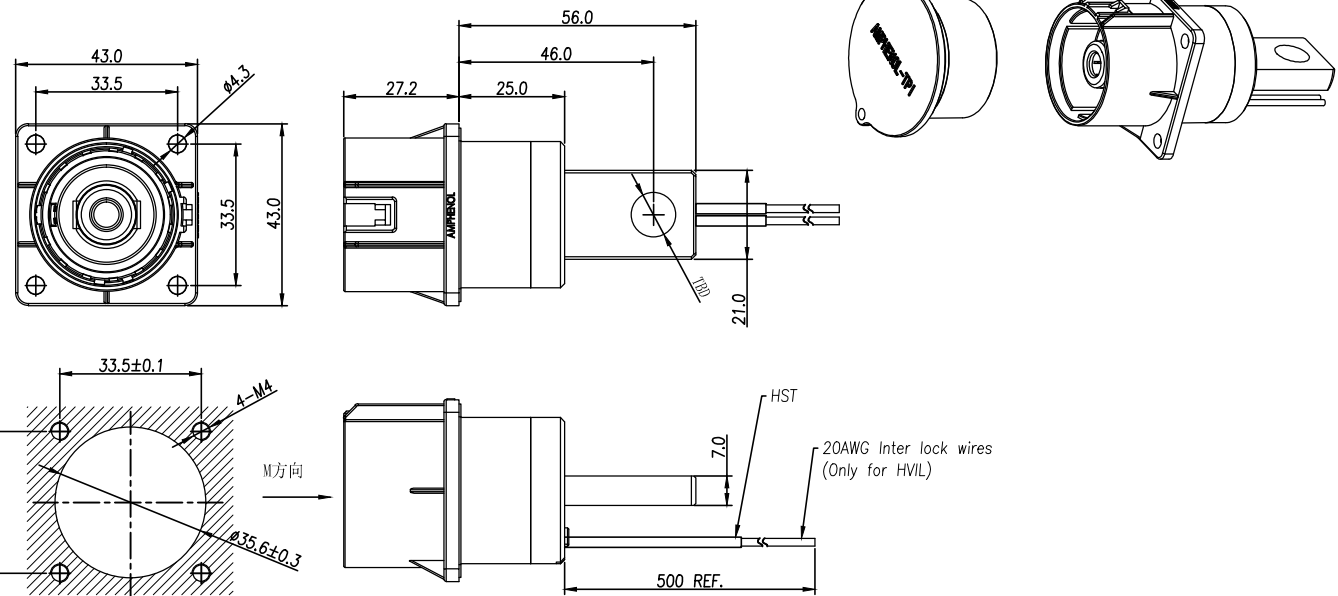

Standard Part List

P/N	Model NO.	Polarization
AC-HA000499	PL00X-500-10D10	X
AC-HA000500	PL00Y-500-10D10	Y
AC-HA000501	PL00U-500-10D10	U
AC-HA000502	PL00V-500-10D10	V
AC-HA000503	PL00W-500-10D10	W
AC-HA000504	PL00X-500-10M10	X
AC-HA000505	PL00Y-500-10M10	Y
AC-HA000506	PL00U-500-10M10	U
AC-HA000507	PL00V-500-10M10	V
AC-HA000508	PL00W-500-10M10	W
△ AC-HA002511	PL00X-500-10M8	X
△ AC-HA002512	PL00Y-500-10M8	Y
△ AC-HA002513	PL00U-500-10M8	U
△ AC-HA002514	PL00V-500-10M8	V
△ AC-HA002515	PL00W-500-10M8	W

△  
△  
△  
△  
△

Standard Part List (With HVIL)

P/N	Model NO.	Polarization
AC-HA000489	PL00X-501-10D10	X
AC-HA000490	PL00Y-501-10D10	Y
AC-HA000491	PL00U-501-10D10	U
AC-HA000492	PL00V-501-10D10	V
AC-HA000493	PL00W-501-10D10	W
AC-HA000494	PL00X-501-10M10	X
AC-HA000495	PL00Y-501-10M10	Y
AC-HA000496	PL00U-501-10M10	U
AC-HA000497	PL00V-501-10M10	V
AC-HA000498	PL00W-501-10M10	W
△ AC-HA002460	PL00X-501-10M8	X
△ AC-HA002461	PL00Y-501-10M8	Y
△ AC-HA002462	PL00U-501-10M8	U
△ AC-HA002463	PL00V-501-10M8	V
△ AC-HA002464	PL00W-501-10M8	W

△  
△  
△  
△  
△

M方向键位示意图

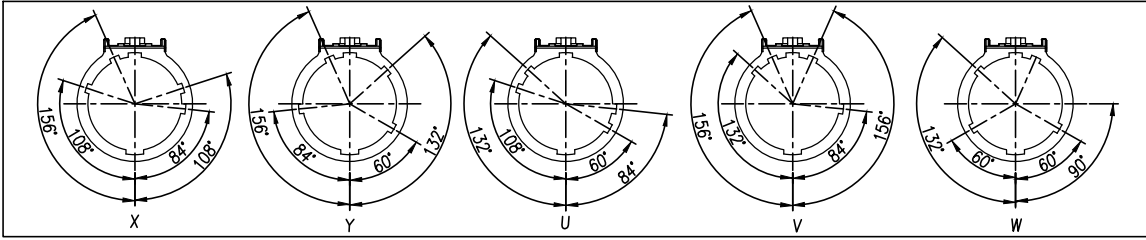

- 规格参数 (Spec.):
- 工作温度 Operating temperature: -40° C~+125° C.
  - 带高压互锁 Electrical interlock (HVIL).
  - 额定电流 Current rating: Power: 500A; HVIL: 5A.
  - 额定电压 Operating voltage: Power: 1000 VDC; Signal: 60 VDC.
  - 耐压 Dielectric withstanding voltage:
    - 与插头对插后, Pin与铁壳之间 After mating, between pin and metal shell :5000 VDC.
    - 与插头对插后, Pin与HVIL之间 After mating, between pin and HVIL :5000 VDC.
    - 与插头对插后, HVIL与铁壳之间 After mating, between HVIL and metal shell :500 VDC.
    - 与插头对插前, 两个HVIL端子之间耐压 Before mating, between two HVIL terminals :500 VDC.
  - 防护等级 Protection class: IP67 & IP2X.
  - 电磁屏蔽 Shielding.
  - 机械寿命 Mating cycle: 500 Min.
  - 带自动二次锁扣 Automatic secondary lock.
  - 铜排推荐安装扭矩 Recommended Fasten Torque on Lug:
    - M6 : 3.6~4.4 Nm
    - M8 : 7.2~8.8 Nm
    - M10: 17.1~20.9 Nm
  - 推荐法兰盘螺丝安装扭矩 Recommended Screw Assembly Torque on Flange : 1.6~2.4 Nm

订购信息 Ordering Information

PL00 X - 50 0 - 10 D 10

键位及颜色 Key & Color	高压互锁 HVIL	孔种类 Hole Type	联接螺栓 Bolt Size
"X", 橙色 Orange "Y", 黑色 Black "U", 黄色 Yellow "V", 绿色 Green "W", 红色 Red	0, 不带互锁 No HVIL 1, 带互锁 With HVIL	D, 通孔 Through Hole M, 螺孔 Screw Hole	Customer Define

	Amphenol Technical Products International GZ				
	第三角投影 THIRD ANGLE PROJECTION	页面 SHEET	幅面 SIZE	版次 REV.	比例 SCALE
1 of 1	A3	C			DWG NO: PL00-500-10
UNLESS OTHERWISE SPECIFIED 1) All dimensions are in metric(mm). 2) Tolerances are as follows: 0 PL DEC ±1.00 1 PL DEC ±0.50 2 PL DEC ±0.20	Angle ±1°			CUST PART #: N/A	CUST REV. -
签名 SIGNATURE	日期 DATE				
制图 DRAWN	NC	05/09/16			
审核 CHECKED	RW	05/09/16			
批准 APPROVAL	GX	05/09/16			

单击下面可查看定价，库存，交付和生命周期等信息

[>>Amphenol\(安费诺\)](#)