

THIS DRAWING IS SUPPLIED FOR INFORMATION ONLY. DESIGN FEATURES, SPECIFICATIONS AND PERFORMANCE DATA SHOWN HEREON ARE THE PROPERTY OF THE AMPHENOL CORPORATION. NO RIGHTS OF REPRODUCTION ARE IMPLIED. ALL DIMENSIONS ARE SUBJECT TO NORMAL MANUFACTURING VARIATIONS.

**Customer Drawing**

6		7			8	
REVISIONS						
REV	ZONE	ECO	DESCRIPTION	DATE	BY	APPR
A	--	--	INITIAL RELEASE	12/01/14	RW	EC
B	--	--	料号从HCTM16XX改为HCTM216XX	01/29/15	RW	EC
C	--	--	Remove the tin-plated terminal	05/12/20	JS	JL

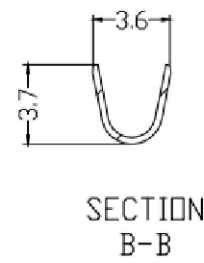
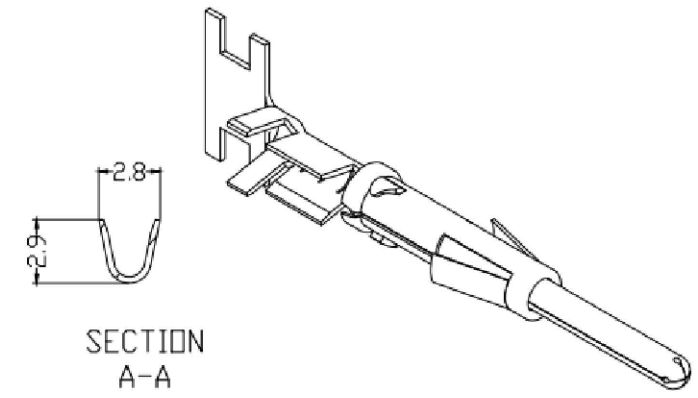
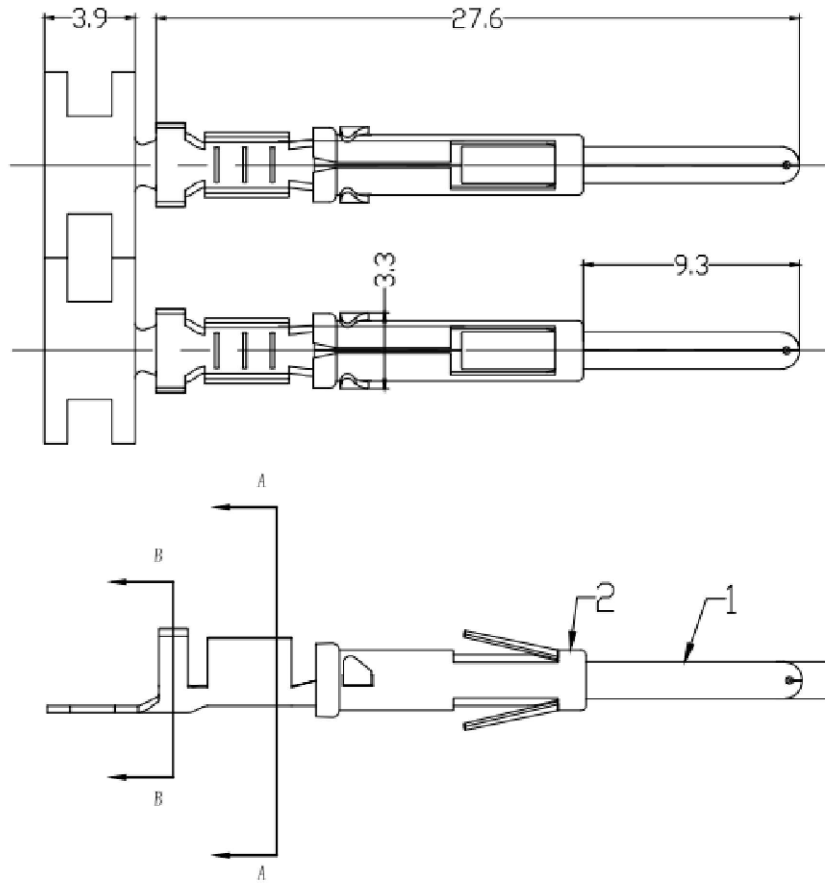

- 注 (NOTES):
- 对配母端直径 Mating contact diameter: 1.6mm
  - 额定电流 Current rating: 13A
  - 端子类型 Terminatin type: Crimp
  - 压线规格 Wire size: AWG16~18
  - 电镀信息 Plating specification:  
 银底, 整个端子飘金.  
 Gold flash plate overall.
  - 材料规格 Material specification:
    1. 端子: 铜合金  
Contact body: Copper alloy
    2. 外套: 不锈钢  
Outer spring: Stainless steel
  - 符合ROHS  
ROHS compliant

<b>AMPHENOL</b> <b>TP</b>	<b>Amphenol Technical Products International GZ</b>					
	第三角投影 THIRD ANGLE PROJECTION	页面 SHEET	幅面 SIZE	版次 REV.	比例 SCALE	PART NAME:  HC Contact 16#Pin 16~18AWG
签名 SIGNATURE	日期 DATE	UNLESS OTHERWISE SPECIFIED			DWG NO:  HCTM21601	
制图 DRAWN	JS	1 OF 1	A3	C	CUST PART #:  N/A	
审核 CHECKED	YM	1) All dimensions are in metric(mm). 2) Tolerances are as follows: 1 PL DEC ±1.00 2 PL DEC ±0.50 3 PL DEC ±0.20			CUST REV.  -	
批准 APPROVAL	JL	05/12/20	Angles ±1°		05/12/20	