

REVISIONS					
REV	ECO	DESCRIPTION	DATE	BY	APPR
B1	-	RELEASE NEW DWG FORMAT	08/14/14	DRACK	TOMMY

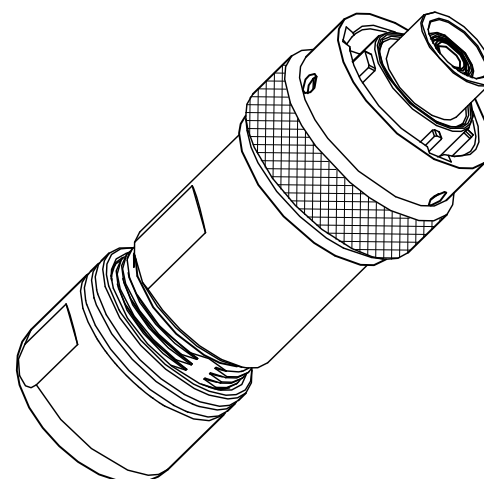
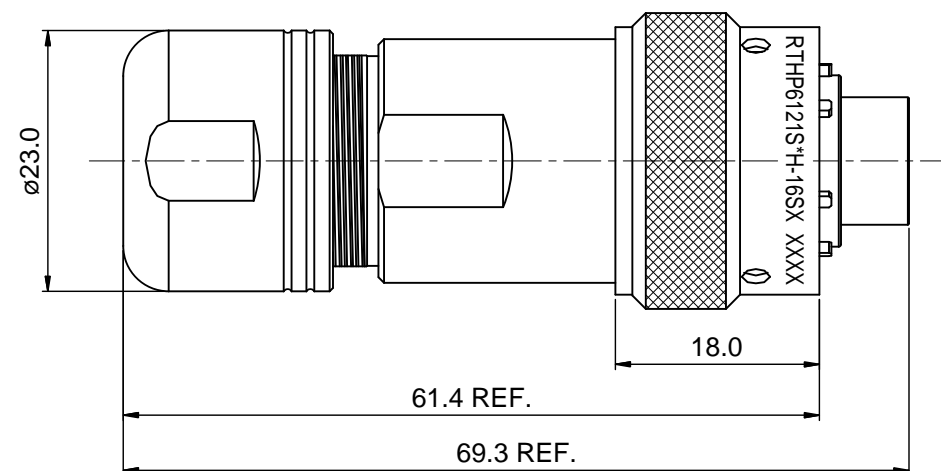
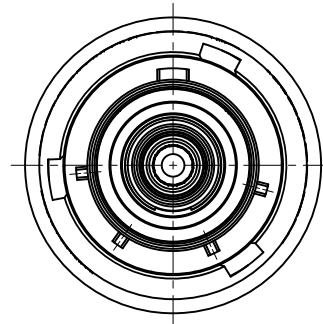
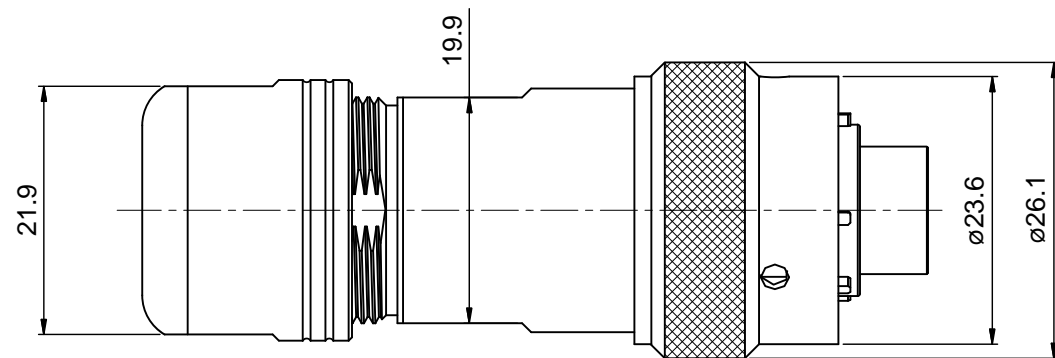

NOTES:

- MATERIAL:
 - HOUSING BODY: ZINC DIE-CAST, NICKEL PLATED
 - COUPLING NUT: AL ALLOY, NICKEL PLATED
 - INSULATION INSERT: PA66,UL94 V0
 - CONTACT: COPPER ALLOY, SILVER PLATED
 - SEAL: SILICONE RUBBER
- SPECIFICATIONS:
 - CURRENT RATING: 86 AMPS MAX.
 - VOLTAGE RATING: 630 V AC/DC
 - OPERATING TEMPERATURE: -40°C TO +125°C
 - DIELECTRIC WITHSTANDING VOLTAGE: LESS THAN 2 MILLIAMPS CURRENT IEAKAGE @ 5000 VOLTS AC
 - DEGREE OF PROTECTION: IP67 (MATED CONDITION)
 - DEGREE OF POLLUTION: 3 PER UL840
 - OVERVOLTAGE CATEGORY: III PER UL840
 - MATING CYCLE DURABILITY: >100 CYCLES
 - RoHS COMPLIANT
- ALL DIMENSIONS ARE FOR REFERENCE USE ONLY.
- *** DENOTE KEY POSTION OF "N","W","X","Y" OR "Z".
- CONTACT P/N: MS6ARS8S

KEY POS	PART NO.	Cable OD Range
N	RTHP6121SNH-16S1	6.0~9.5 mm
W	RTHP6121SWH-16S1	
X	RTHP6121SXH-16S1	
Y	RTHP6121SYH-16S1	
Z	RTHP6121SZH-16S1	

KEY POS	PART NO.	Cable OD Range
N	RTHP6121SNH-16S2	9.5~12.5 mm
W	RTHP6121SWH-16S2	
X	RTHP6121SXH-16S2	
Y	RTHP6121SYH-16S2	
Z	RTHP6121SZH-16S2	

QUANTITY	SEE PART NUMBER PART NUMBER	DESCRIPTION	ITEM								
MATERIALS LIST											
UNLESS OTHERWISE SPECIFIED 1) All dimensions are in metric(mm). 2) Tolerances are as follows: 1 PL DEC ±0.30 2 PL DEC ±0.15 3 PL DEC ±0.08 3) Note reference =		SIGNATURES DRAWN: Drack CHECKED: ENGINEER: APPROVAL:	DATE 08/14/14								
MATERIAL SPECIFICATIONS:		<p style="text-align: center;">Amphenol</p> <p style="text-align: center;">Sine Systems - www.amphenol-sine.com 44724 Morley Drive Clinton Township, MI 48036</p> <p style="text-align: center;">ECO-MATE,PLUG,3.6mm RADSOK, CRIMP TYPE,SHIELDING,CORD GRIP</p>									
PROCESS SPECIFICATIONS:											
NEXT ASSY:		CUSTOMER: THIS DRAWING IS SUPPLIED FOR INFORMATION ONLY. DESIGN FEATURES, SPECIFICATIONS AND PERFORMANCE DATA SHOWN HEREON ARE THE PROPERTY OF THE AMPHENOL CORPORATION. NO RIGHTS OF REPRODUCTION ARE IMPLIED. ALL DIMENSIONS ARE SUBJECT TO NORMAL MANUFACTURING VARIATIONS.	<table border="1"> <tr> <td>SIZE</td> <td>TYPE</td> <td>DWG NO.</td> <td>REVISION</td> </tr> <tr> <td>B</td> <td>C-</td> <td>RTHP6121S*H-16Sx</td> <td>B1</td> </tr> </table>	SIZE	TYPE	DWG NO.	REVISION	B	C-	RTHP6121S*H-16Sx	B1
SIZE	TYPE	DWG NO.	REVISION								
B	C-	RTHP6121S*H-16Sx	B1								
SCALE: 3 : 2		SHEET 1 OF 1									

TITLE: ECO-MATE,PLUG,3.6mm RADSOK,CRIMP TYPE,SHIELDING,CORD GRIP
DWG NO: RTHP6121S*H-16SX
REV: B1
SH: 1
OF: 1

单击下面可查看定价，库存，交付和生命周期等信息

[>>Amphenol\(安费诺\)](#)