

REV.	ECN NO.	DATE	SIGN	DESCRIPTION
B	LEN-8B0573	2008/09/10	Shin	Add Note

ALTW
CONFIDENTIAL
 2012-03-26
R&D DEPT.

ALTW
DCC. DEPT.
CONFIDENTIAL
 2012-04-03
ISSUED

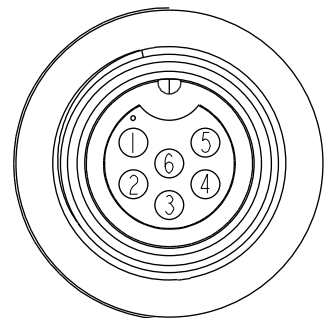
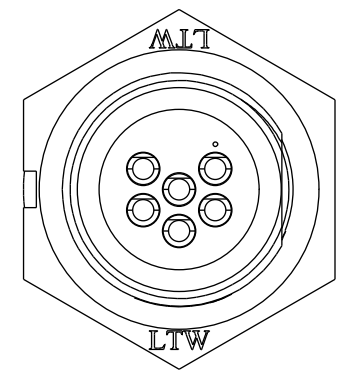
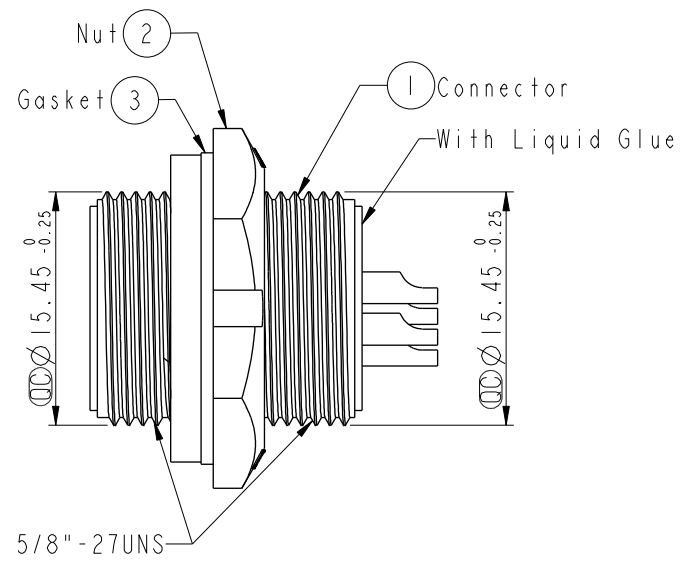
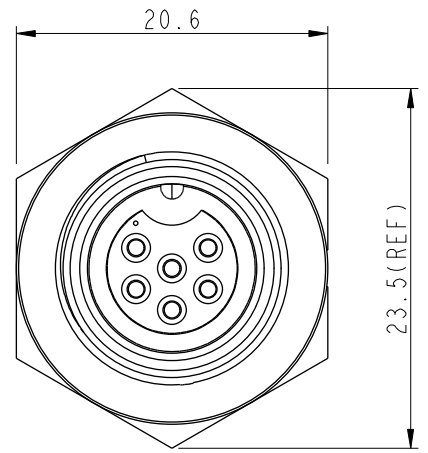

Pin Assignments
 Front View

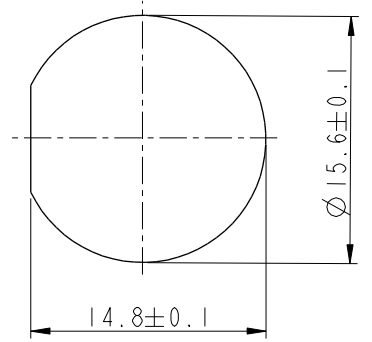

Recommended Panel Cut-out

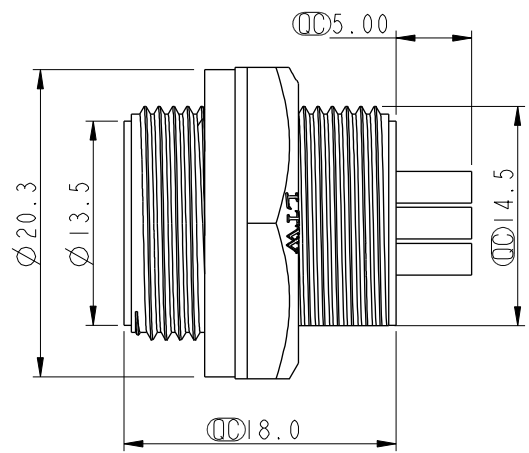

Note:

- * \varnothing Important Dimension To Check.
- * Waterproof Rate: IP67
- * Housing: Nylon+GF, Black
- * Pin: Copper Alloy, Gold Plated
- * Nut: Nylon+GF, Black
- * Gasket: EPDM, Black
- $\triangle B$ * Use With Waterproof Cap Or Dust Cap
 Panel Thickness Max: 4.0mm
- $\triangle B$ * Use Without Waterproof Cap Or Dust Cap
 Panel Thickness Max: 5.0mm

UNIT:mm		
TOLERANCE	.X ±0.25	
.XX ±0.1		
.XXX ±0.05		
ANGLES	±1°	

TITLE Standard, Rear Screw 6P M Conn F Pin			
SCALE 2:1	SIZE A4	SHEET 1 OF 1	
REV. B	WC-REV. A.2	\varnothing : Inspection item	

Amphenol LTW
 安費諾亮泰企業股份有限公司

ITEM NO. BD-06RMFS-SC7001	DRAWN BY SamChang	DATE 2012-03-26
DWG NO. BD-06RMFS-SC7001	CHECKED BY Jeffrey	DATE 2012-04-03
CUSTOMER ALTW	APPROVED BY Lion	DATE 2012-04-03

THIS DOCUMENT IS SUBJECT TO CHANGE WITHOUT NOTICE. IT IS CONFIDENTIAL AND A PROPERTY OF AMPHENOL LTW. DISCLOSURE TO THIRD PARTY HAS TO BE AUTHORIZED BY AMPHENOL LTW.

单击下面可查看定价，库存，交付和生命周期等信息

[>>Amphenol\(安费诺\)](#)