

THIS DRAWING IS SUPPLIED FOR INFORMATION ONLY. DESIGN FEATURES, SPECIFICATIONS AND PERFORMANCE DATA SHOWN HEREON ARE THE PROPERTY OF THE AMPHENOL CORPORATION. NO RIGHTS OF REPRODUCTION ARE IMPLIED. ALL DIMENSIONS ARE SUBJECT TO NORMAL MANUFACTURING VARIATIONS.

CUSTOMER DRAWING

REVISIONS					
REV#	ECN#	REVISION ACTION	REV.BY:	APPR.BY:	DATE
A	--	INITIAL RELEASE	JX	JL	03/09/2020
B	--	Add new parts and Key U/V	Star	JL	10/15/2020

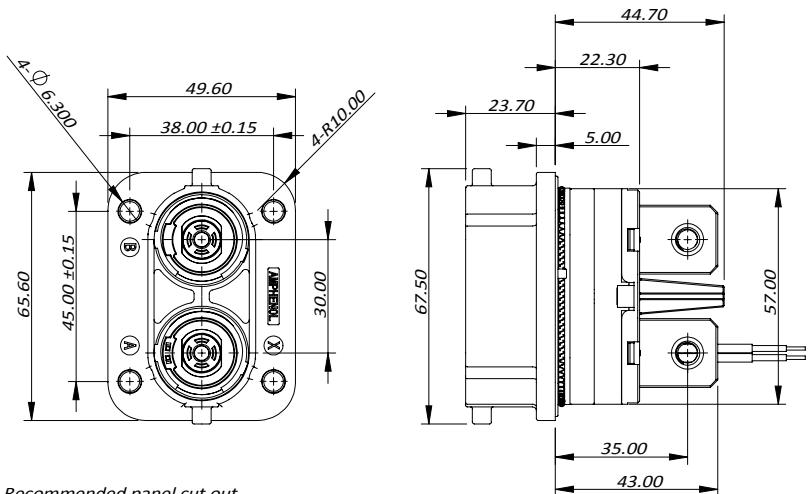

Recommended panel cut out

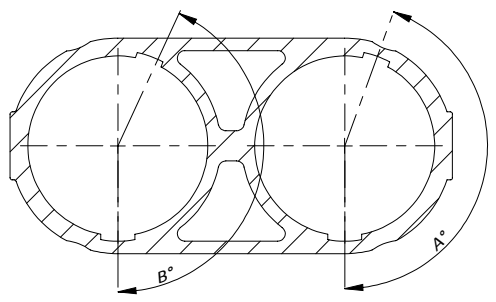
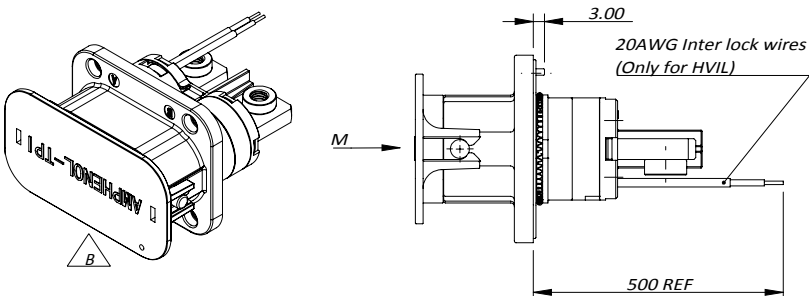
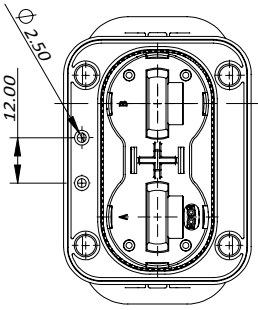

M向键位示意图

Key	角度A°	角度B°
X	160	160
Y	200	200
U	160	200
V	200	160

规格参数(Spec.):

1. 工作温度 Operating temperature : -40°C ~ +125°C.
2. 带高压互锁 Electrical interlock (HVIL).
3. 额定电流 Current rating:
Power: 300A; HVIL: 5A.
4. 额定电压 Operating voltage:
Power: 1000 VDC; Signal: 60 VDC.
5. 耐电压 Dielectric withstanding voltage:
A. 与插座对插后, Pin与铁壳之间
When mated, between pin and metal shell: 5000 VDC.
B. 与插座对插后, Pin与HVIL之间
When mated, between pin and HVIL: 5000 VDC.
C. 与插座对插后, HVIL与铁壳之间
When mated, between HVIL and metal shell: 500 VDC.
D. 与插座对插前, 两个HVIL端子之间耐压
Before mating, between two HVIL terminals: 500 VDC.
6. 防护等级 Protection class: Mated-IP6k9k & IP67, unmated-IP2X.
7. 电磁屏蔽 360° full Shielding.
8. 机械寿命 Mating cycle: 100 Min.
9. 推荐法兰盘螺丝安装扭矩 Recommended Screw
Assembly Torque on Flange : 6.2~7.6Nm
10. 推荐铜排安装扭矩 Recommended Fasten Torque on Lug:
M6: 3.6~4.4Nm, M8: 7.2~8.8Nm, M10: 17.1~20.9Nm
11. 镀灰锌/锌镍合金, 符合RoHS, 满足500H中性盐雾实验
Gray Zinc/Nickel(ZnNi) Plating. RoHS compliant, Rated at 500hours salt spray.

订购信息 Ordering Information

PL082 X - 30 1 - 10 PM 6 - 2

Key and Color "X", Orange "Y", Black "U", Yellow "V", Green	HVIL "0", NO HVIL "1", With HVIL	Hole Type "D", through hole "M", thread hole "H", slot hole "PM", punched nut	Hole Size
--	---	--	------------------

	Amphenol Technical Products International Asia.					PART NAME: PwrLok 10mm G2 2POS Rcpt Lug
	第三角投影 THIRD ANGLE PROJECTION	页面 SHEET 1 OF 2	幅面 SIZE A4	版次 REV. B	比例 SCALE --	
签名 SIGNATURE Star	日期 DATE 10/15/2020	UNLESS OTHERWISE SPECIFIED 1) All dimensions are in metric(mm). 2) Tolerances are as follows: 1.PL DEC ± 1.00 2.PL DEC ± 0.50 3.PL DEC ± 0.20			CUST PART #	CUST REV.
制图 DRAWN	审核 CHECKED	批准 APPROVAL	Angles ±1°			

THIS DRAWING IS SUPPLIED FOR INFORMATION ONLY. DESIGN FEATURES, SPECIFICATIONS AND PERFORMANCE DATA SHOWN HEREON ARE THE PROPERTY OF THE AMPHENOL CORPORATION. NO RIGHTS OF REPRODUCTION ARE IMPLIED. ALL DIMENSIONS ARE SUBJECT TO NORMAL MANUFACTURING VARIATIONS.

1	2	3	4
型号	AC P/N	型号	AC P/N
PL082X-300-10M6-2	AC-HA010932	PL082X-301-10M8-2	AC-HA010946
PL082Y-300-10M6-2	AC-HA010933	PL082Y-301-10M8-2	AC-HA010947
PL082U-300-10M6-2	AC-HA016971	PL082U-301-10M8-2	AC-HA016995
PL082V-300-10M6-2	AC-HA016972	PL082V-301-10M8-2	AC-HA016996
PL082X-300-10M8-2	AC-HA010934	PL082X-301-10D6-2	AC-HA010950
PL082Y-300-10M8-2	AC-HA010935	PL082Y-301-10D6-2	AC-HA010951
PL082U-300-10M8-2	AC-HA016975	PL082U-301-10D6-2	AC-HA016999
PL082V-300-10M8-2	AC-HA016976	PL082V-301-10D6-2	AC-HA017000
PL082X-300-10D6-2	AC-HA010938	PL082X-301-10D8-2	AC-HA010952
PL082Y-300-10D6-2	AC-HA010939	PL082Y-301-10D8-2	AC-HA010953
PL082U-300-10D6-2	AC-HA016979	PL082U-301-10D8-2	AC-HA017003
PL082V-300-10D6-2	AC-HA016980	PL082V-301-10D8-2	AC-HA017004
PL082X-300-10D8-2	AC-HA010940	PL082X-301-10D10-2	AC-HA010954
PL082Y-300-10D8-2	AC-HA010941	PL082Y-301-10D10-2	AC-HA010955
PL082U-300-10D8-2	AC-HA016983	PL082U-301-10D10-2	AC-HA017007
PL082V-300-10D8-2	AC-HA016984	PL082V-301-10D10-2	AC-HA017008
PL082X-300-10D10-2	AC-HA010942	PL082X-301-10PM6-2	AC-HA011979
PL082Y-300-10D10-2	AC-HA010943	PL082Y-301-10PM6-2	AC-HA011980
PL082U-300-10D10-2	AC-HA016987	PL082U-301-10PM6-2	AC-HA017015
PL082V-300-10D10-2	AC-HA016988	PL082V-301-10PM6-2	AC-HA017016
PL082X-300-10PM6-2	AC-HA011977		
PL082Y-300-10PM6-2	AC-HA011978		
PL082U-300-10PM6-2	AC-HA017011		
PL082V-300-10PM6-2	AC-HA017012		
PL082X-301-10M6-2	AC-HA010944		
PL082Y-301-10M6-2	AC-HA010945		
PL082U-301-10M6-2	AC-HA016991		
PL082V-301-10M6-2	AC-HA016992		

REVISIONS					
REV#	ECN#	REVISION ACTION	REV.BY:	APPR.BY:	DATE
A	--	INITIAL RELEASE	JX	JL	03/09/2020
B	--	Add new parts and Key U/V/W/T	Star	JL	10/15/2020

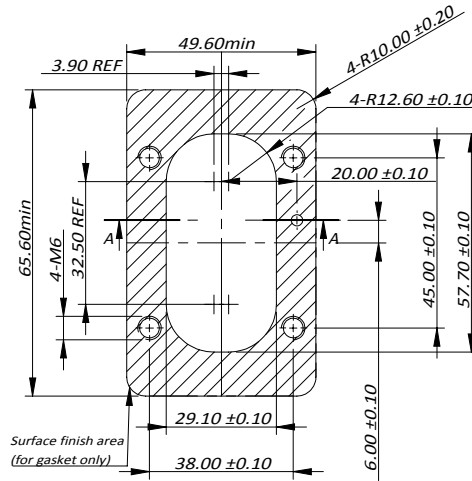

X Key

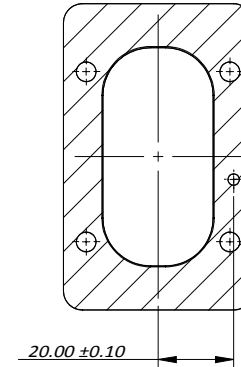

Y Key

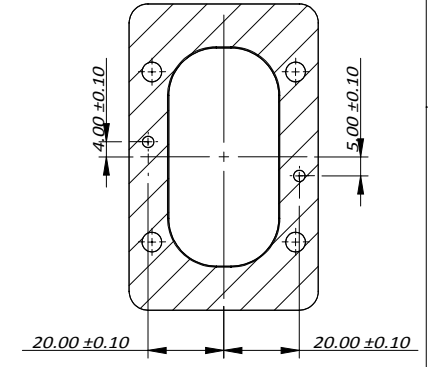

U Key

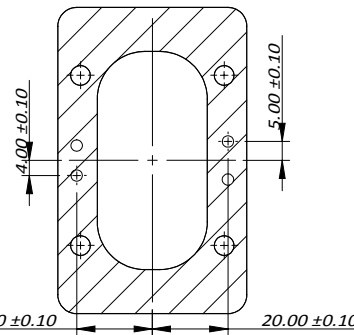

V Key

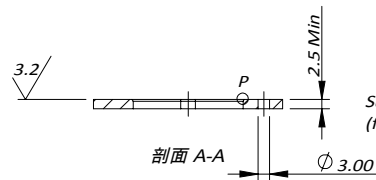

剖面 A-A

$C0.30 \pm 0.10 \times 60^\circ$ (for coil spring lead in)

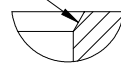

局部视图 P
比例 5:1

		Amphenol Technical Products International Asia.					PART NAME: PwrLok 10mm G2 2POS Rcpt Lug
		第三角投影 THIRD ANGLE PROJECTION	页面 SHEET	幅面 SIZE	版次 REV.	比例 SCALE	
签名 SIGNATURE Star		日期 DATE 10/15/2020	UNLESS OTHERWISE SPECIFIED 1) All dimensions are in metric(mm). 2) Tolerances are as follows: 1.PL DEC ± 1.00 2.PL DEC ± 0.50 3.PL DEC ± 0.20			DWG NO: PL082X-30X-10XX-2	
审核 CHECKED		批准 APPROVAL	Angles ±1°			CUST PART # 	CUST REV.

单击下面可查看定价，库存，交付和生命周期等信息

[>>Amphenol\(安费诺\)](#)