

MOUNTING PLATE SIZE

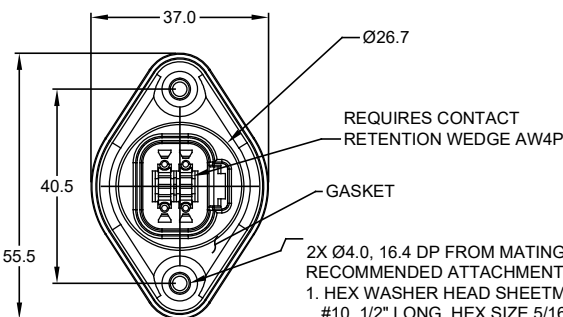
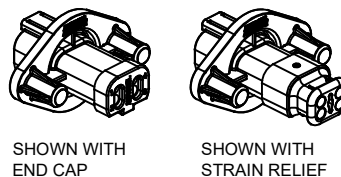
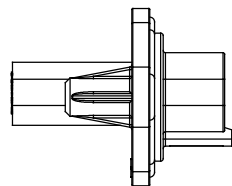
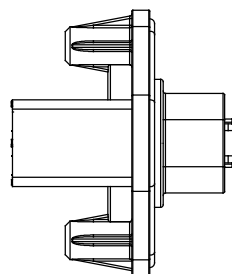
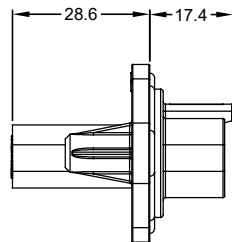
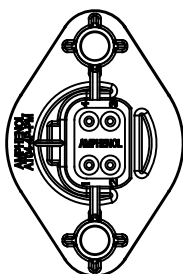

| REVISIONS | | | | | |
|-----------|-----|--------------------------|---------|-----|------|
| REV | ECO | DESCRIPTION | DATE | BY | APPR |
| A1 | - | RELEASED CHARTED DRAWING | 23MAR18 | JAH | - |

NOTES: UNLESS OTHERWISE SPECIFIED

- MATERIAL:
HOUSING: THERMOPLASTIC; COLOR: BLACK
END CAP: THERMOPLASTIC; COLOR: BLACK
STRAIN RELIEF CAP: THERMOPLASTIC; COLOR: BLACK
SEALS: SILICONE RUBBER; COLOR: RED
- MODIFICATIONS: FLANGE, GASKET, END CAP (OPT), STRAIN RELIEF CAP (OPT), REDUCED DIAMETER SEAL (OPT).
- SPECIFICATIONS:
3.1 CURRENT RATING: 13 AMPS
3.2 OPERATING TEMPERATURE: -55°C TO +125°C
3.3 DIELECTRIC WITHSTANDING VOLTAGE: LESS THAN 2 MILLIAMPS CURRENT LEAKAGE @ 1500 VOLTS AC.
3.4 INSULATION RESISTANCE: 1000 MEGOHMS MIN @ 25°C.
3.5 MOISTURE RESISTANCE: IP67 (MATED CONDITION)
3.6 MATING CYCLE DURABILITY: 100 CYCLES
3.7 RoHS COMPLIANT
- MATING PART: AT06-4S* PLUG
(* = MODIFICATIONS)
- ALL DIMENSIONS ARE FOR REFERENCE USE ONLY.

6 CONTACT SIZE AND REAR SEAL WIRE RANGE:

REDUCED DIAMETER SEAL:

| CONTACT SIZE | MIN. INSUL O.D. | MAX. INSUL O.D. | TYPICAL WIRE RANGE |
|--------------|-------------------|-------------------|--------------------|
| 16 | 1.35 mm (.053 in) | 3.05 mm (.120 in) | 14 - 20 AWG |

STANDARD SEAL:

| CONTACT SIZE | MIN. INSUL O.D. | MAX. INSUL O.D. | TYPICAL WIRE RANGE |
|--------------|-------------------|-------------------|--------------------|
| 16 | 2.24 mm (.088 in) | 3.68 mm (.145 in) | 14 - 20 AWG |

| MODIFICATIONS | | | |
|---------------|--------------|---------|---------------|
| PART NUMBER | SEAL | END CAP | STRAIN RELIEF |
| AT04-4P-PM11 | STANDARD | NO | NO |
| AT04-4P-PM12 | REDUCED DIA. | NO | NO |
| AT04-4P-PM13 | STANDARD | YES | NO |
| AT04-4P-PM14 | REDUCED DIA. | YES | NO |
| AT04-4P-PM15 | STANDARD | NO | YES |
| AT04-4P-PM16 | REDUCED DIA. | NO | YES |

| | | | | | | |
|------------------------------------------------------------------------------------------------------------------------------------------------------------------------------------|--|----------------------------------------------------------------------------------------------------------------------------------------------------------------------------------------------------------------------------------------------------------------------|--|-------------------------------------------------------------------------------|--|------------------------------------------------------------------------------------------------------------------------------------------------------------------------------------|
| AT04-4P-PM1X | | PART NUMBER | | DESCRIPTION | | ITEM |
| QUANTITY | | MATERIALS LIST | | | | |
| UNLESS OTHERWISE SPECIFIED: 1) All dimensions are in metric (mm). 2) Tolerances are as follows: 1 PL DEC ±0.30 2 PL DEC ±0.15 3 PL DEC ±0.08 3) Note reference = | | SIGNATURES | | DATE | | <p>Amphenol</p> <p>Sine Systems - www.amphenol-sine.com 44724 Morley Drive Clinton Township, MI 48036</p> <p>RECEPTACLE, 4 PIN, AT SERIES, W/FLANGE, GASKET</p> |
| DRAWN: J. HEAD | | 23MAR18 | | CHECKED: | | |
| ENGINEER: | | APPROVAL: | | CUSTOMER: | | |
| MATERIAL SPECIFICATIONS: | | THIS DRAWING IS SUPPLIED FOR INFORMATION ONLY. DESIGN FEATURES, SPECIFICATIONS AND PERFORMANCE DATA SHOWN HEREON ARE THE PROPERTY OF THE AMPHENOL CORPORATION. NO RIGHTS OF REPRODUCTION ARE IMPLIED. ALL DIMENSIONS ARE SUBJECT TO NORMAL MANUFACTURING VARIATIONS. | | SIZE: B TYPE: C DWG NO: AT04-4P-PM1X REVISION: A1 | | |
| NEXT ASSY: | | SCALE: NONE | | SHEET 1 OF 1 | | |

TITLE: RECEPTACLE, 4 PIN, AT SERIES, W/FLANGE, GASKET
DWG NO: AT04-4P-PM1X
REV: A1
SH: 1
OF: 1

单击下面可查看定价，库存，交付和生命周期等信息

[>>Amphenol\(安费诺\)](#)