

REVISIONS					
REV	ECO	DESCRIPTION	DATE	BY	APPR
A1	-	RELEASE NEW DWG FORMAT	12/JUN/15	ORION	-
A2	-	CORRECT SECTION DIMENSIONS	29/MAR/17	ORION	TOMMY
A3	C1070S	UPDATE DRAWING	28/JUN/19	JOE	TOMMY

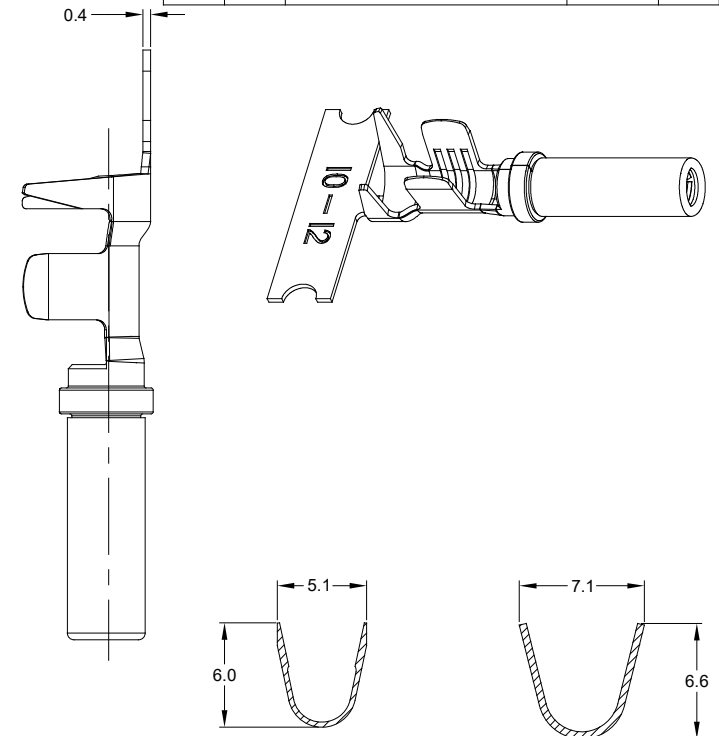
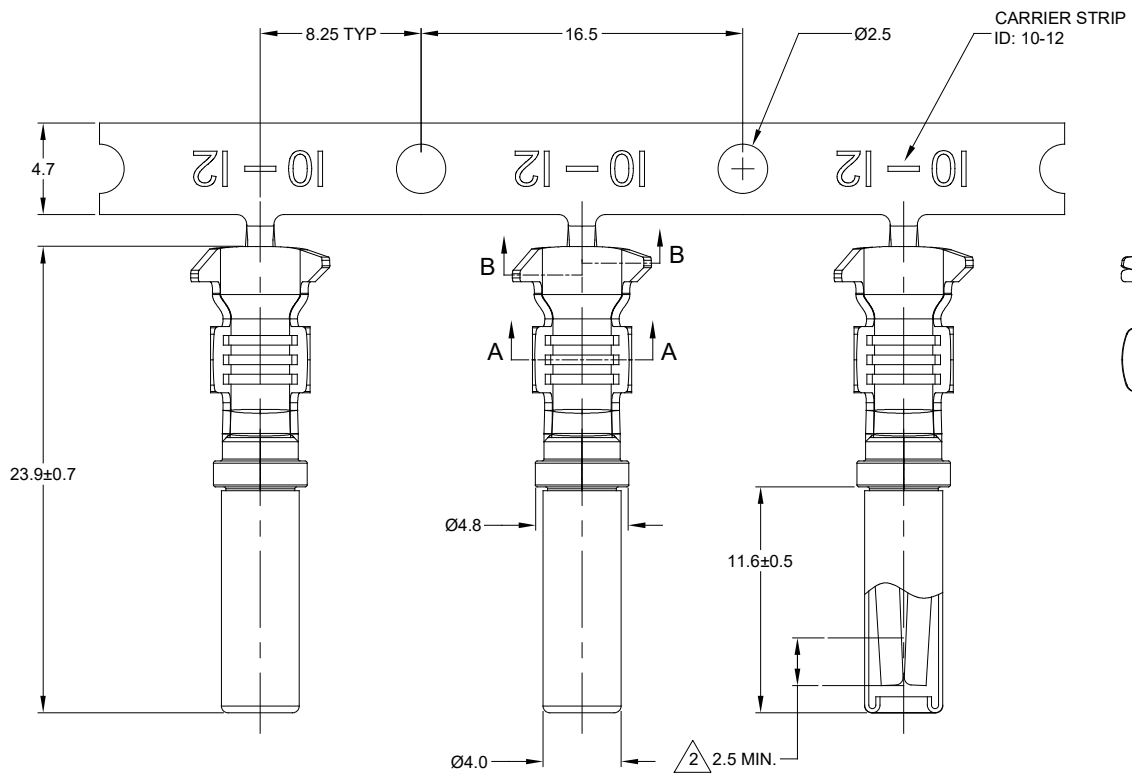

NOTES: UNLESS OTHERWISE SPECIFIED

1. MATERIAL: COPPER ALLOY
2. PLATING: SEE PART NUMBER CHART
*FOR GOLD PLATED CONTACTS: SELECTIVE GOLD FLASH IN CONTACT ZONE OR ENTIRE CONTACT.
3. CONTACT SIZE: 12
4. SPECIFICATIONS:
4.1 CURRENT RATING: 25 AMPS
4.2 CONTACT MILLIVOLT DROP: 100 MILLIVOLT DROP @ 25 AMP TEST CURRENT.
4.3 RoHS COMPLIANT
5. RECOMMENDED WIRE RANGE: 10 - 12 AWG
6. PACKAGE: 2000 PCS/REEL
7. ALL DIMENSIONS ARE FOR REFERENCE USE ONLY

PART NUMBER CHART	
PLATING	PART NUMBER
NICKEL	AT62-12-0222
GOLD	AT62-12-0244

SEE PART NUMBER CHART		REF: 1062-12-0222, 1062-12-0244	
PART NUMBER		DESCRIPTION	
QUANTITY	MATERIALS LIST		
UNLESS OTHERWISE SPECIFIED: 1) All dimensions are in metric (mm). 2) Tolerances are as follows: 1 PL DEC ±0.30 2 PL DEC ±0.15 3 PL DEC ±0.08 Fractions ±1/64 Angles ±1°		SIGNATURES	DATE
3) Note reference =		DRAWN: JOE SONG	28/JUN/19
MATERIAL SPECIFICATIONS:		CHECKED: ORION LI	28/JUN/19
PROCESS SPECIFICATIONS:		ENGINEER:	
NEXT ASSY:		APPROVAL: TOMMY XIE	28/JUN/19
		CUSTOMER:	
		THIS DRAWING IS SUPPLIED FOR INFORMATION ONLY. DESIGN FEATURES, SPECIFICATIONS AND PERFORMANCE DATA SHOWN HEREON ARE THE PROPERTY OF THE AMPHENOL CORPORATION. NO RIGHTS OF REPRODUCTION ARE IMPLIED. ALL DIMENSIONS ARE SUBJECT TO NORMAL MANUFACTURING VARIATIONS.	
SIZE: B C-	TYPE: DWG NO: AT62-12-02XX	REVISION: A3	
SCALE: NONE	SHEET 1 OF 1		

TITLE: CONTACT, STAMPED, SIZE 12, 10-12 AWG, A SERIES
DWG NO: AT62-12-02XX
REV: A3
SH: 1
OF: 1

单击下面可查看定价，库存，交付和生命周期等信息

[>>Amphenol\(安费诺\)](#)