

REVISIONS				
REV.	ZONE	DESCRIPTION	DATE	APPROVED
E		PLATING 5 & 6 ADDED	2007/04/05	A.G
F		MATING END GAP DIM. ADDED	2008/09/03	A.G
G		DRAWING UPDATE	2012/03/21	ZLJ
H		DRAWING UPDATE	2012/10/26	ZLJ

PLASTIC HOUSING:
HIGH TEMPERATURE RESISTANT PLASTIC
COLOUR: BLACK
FLAMMABILITY RATING UL94V-0

PACKAGING:
TAPE AND REEL RACKAGING

TEMPERATURE RANGE:
-40°C TO +85°C

MATERIAL NOTES

CONTACTS:
PHOSPHOR BRONZE

PLATING OPTION 2: (RoHS FOR UE75 ONLY)
30µ" [0.76 µm] MIN. GOLD ON MATING AREA AND 2µ" [0.05 µm] GOLD FLASH PLATING ON TERMINATION OVER 50µ" [1.27 µm] MIN. NICKEL UNDER LAYER

PLATING OPTION 3: (RoHS FOR UE75 ONLY)
30µ" [0.76 µm] MIN. GOLD ON MATING AREA AND 100 - 150µ" [3.81 - 7.62 µm] MIN. LOW WHISKER MATTE TIN PLATING ON TERMINATION OVER 50µ" [1.27 µm] MIN. NICKEL UNDER LAYER

PLATING OPTION 5: (RoHS FOR UE75 ONLY)
15µ" [0.38 µm] MIN. GOLD ON MATING AREA AND 2µ" [0.05 µm] GOLD FLASH PLATING ON TERMINATION OVER 50µ" [1.27 µm] MIN. NICKEL UNDER LAYER

PLATING OPTION 6: (RoHS FOR UE75 ONLY)
15µ" [0.38 µm] MIN. GOLD ON MATING AREA AND 100 - 150µ" [3.81 - 7.62 µm] MIN. LOW WHISKER MATTE TIN PLATING ON TERMINATION OVER 50µ" [1.27 µm] MIN. NICKEL UNDER LAYER



AMPHENOL PART NUMBER CONFIGURATION

UE75 - A 30 - X 0 0 0 T

CONTACT PLATING (SEE MATERIAL NOTES)

(FOR UE75 RoHS)
2 = PLATING OPTION 2
3 = PLATING OPTION 3
5 = PLATING OPTION 5
6 = PLATING OPTION 6

DO NOT SCALE DRAWING

THIS DOCUMENT CONTAINS PROPRIETARY INFORMATION AND SUCH INFORMATION MAY NOT BE DISCLOSED TO OTHERS FOR ANY PURPOSE OR USED FOR MANUFACTURING PURPOSES WITHOUT PERMISSION FROM AMPHENOL CANADA CORP.

UNLESS OTHERWISE SPECIFIED DIMENSIONS ARE IN MILLIMETERS TOLERANCES ARE:		APPROVALS		DATE		Amphenol High Speed Interconnects <small>A Division of Amphenol Corp. www.amphenolhighspeed.com</small>	
DECIMALS	ANGLES	DRAWN	J. SI	2005/12/02	TITLE		
		DESIGNED	J. SI	2005/12/02	XFP 30 POSITION HIGH SPEED CONNECTOR RECEPTACLE FIXED BOARD, RIGHT ANGLE SMT		
MATERIAL AND FINISH		CHECKED	X	X			
N/A		QA APPD					
REF.		E APPD			SIZE	DWG. NO.	REV.
CODE IDENT. NO.	03554	DWG APPD			A	P-UE75-A30-X000T	H
		SCALE		PROJECT		SHEET	
		NTS				1 OF 3	

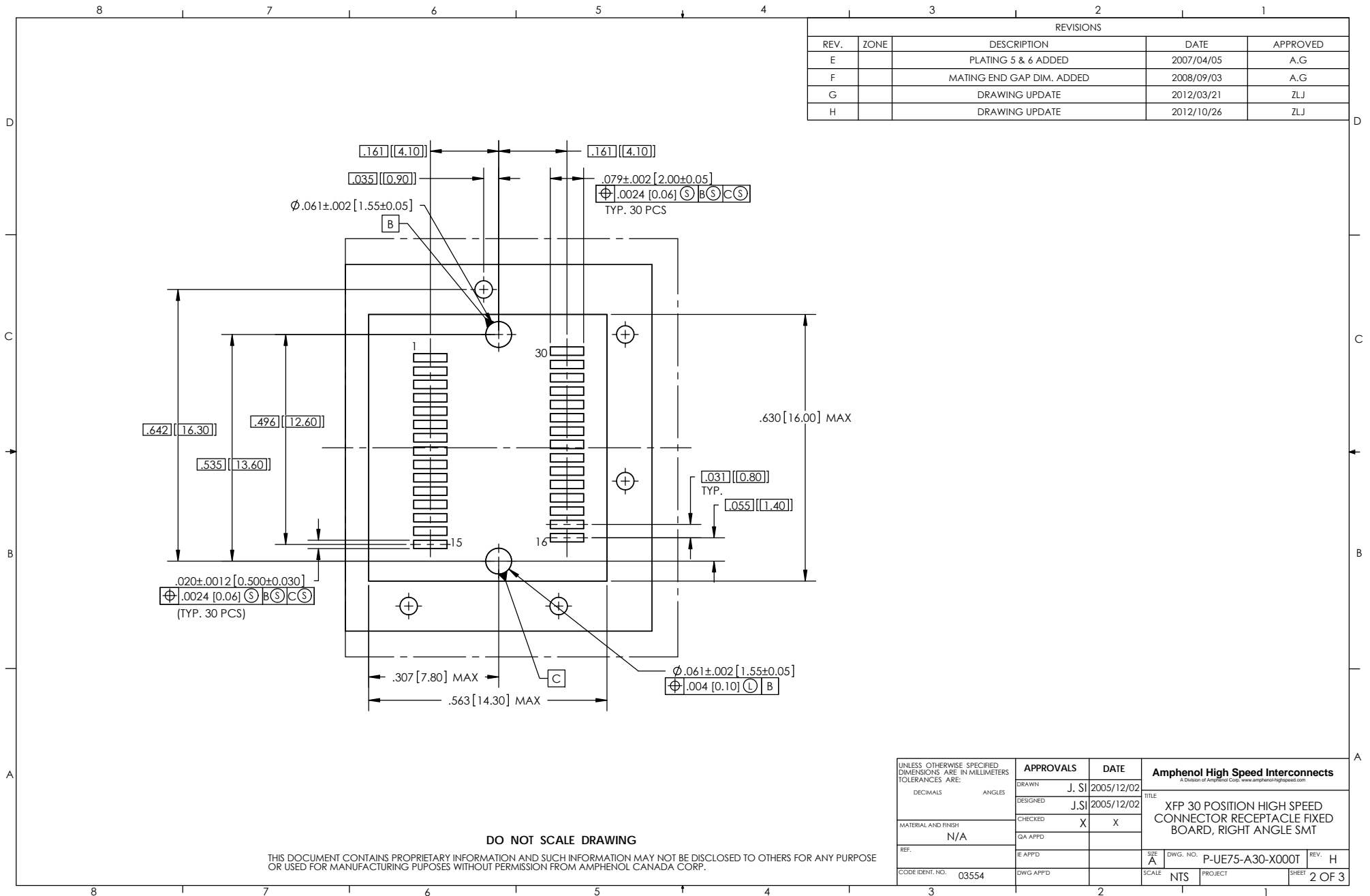

REVISIONS				
REV.	ZONE	DESCRIPTION	DATE	APPROVED
E		PLATING 5 & 6 ADDED	2007/04/05	A.G
F		MATING END GAP DIM. ADDED	2008/09/03	A.G
G		DRAWING UPDATE	2012/03/21	ZLJ
H		DRAWING UPDATE	2012/10/26	ZLJ

DO NOT SCALE DRAWING

THIS DOCUMENT CONTAINS PROPRIETARY INFORMATION AND SUCH INFORMATION MAY NOT BE DISCLOSED TO OTHERS FOR ANY PURPOSE OR USED FOR MANUFACTURING PURPOSES WITHOUT PERMISSION FROM AMPHENOL CANADA CORP.

UNLESS OTHERWISE SPECIFIED DIMENSIONS ARE IN MILLIMETERS TOLERANCES ARE:		APPROVALS		DATE		Amphenol High Speed Interconnects <small>A Division of Amphenol Corp. www.amphenolhighspeed.com</small>	
DECIMALS	ANGLES	DRAWN	J. SI	2005/12/02	TITLE		
		DESIGNED	J. SI	2005/12/02	XFP 30 POSITION HIGH SPEED CONNECTOR RECEPTACLE FIXED BOARD, RIGHT ANGLE SMT		
MATERIAL AND FINISH		CHECKED	X	X	REV. H		
N/A		QA APPD			SIZE A		
REF.		E APPD			DWG. NO.	P-UE75-A30-X000T	
CODE IDENT. NO.	03554	DWG APPD			SCALE	NTS	SHEET 2 OF 3

REVISIONS				
REV.	ZONE	DESCRIPTION	DATE	APPROVED
E		PLATING 5 & 6 ADDED	2007/04/05	A.G
F		MATING END GAP DIM. ADDED	2008/09/03	A.G
G		DRAWING UPDATE	2012/03/21	ZLJ
H		DRAWING UPDATE	2012/10/26	ZLJ

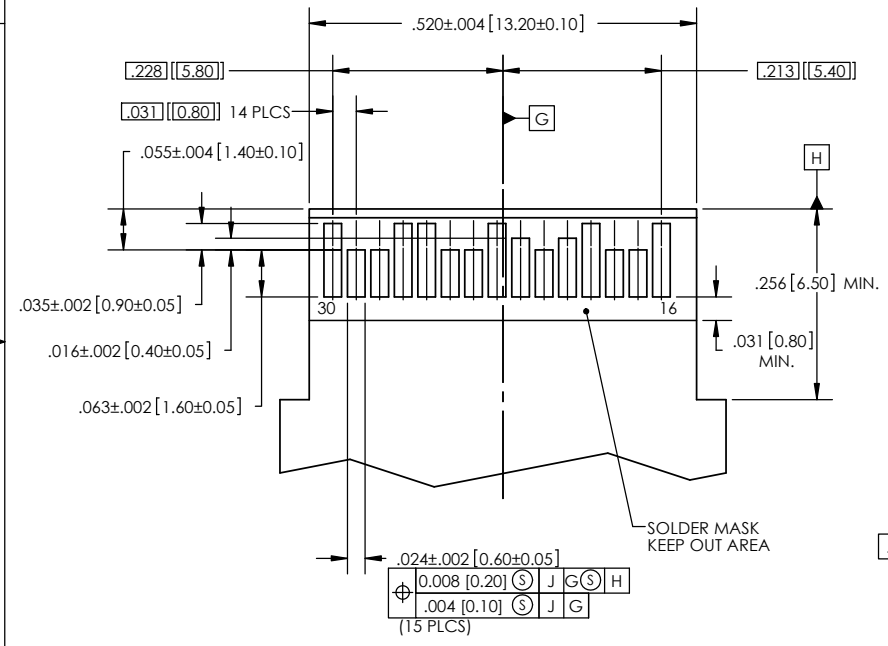

TOP VIEW OF BOARD

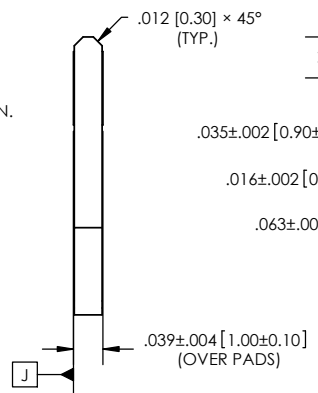

RECOMMENDED LAYOUT DETAIL
MATING TRANSCEIVER PCB

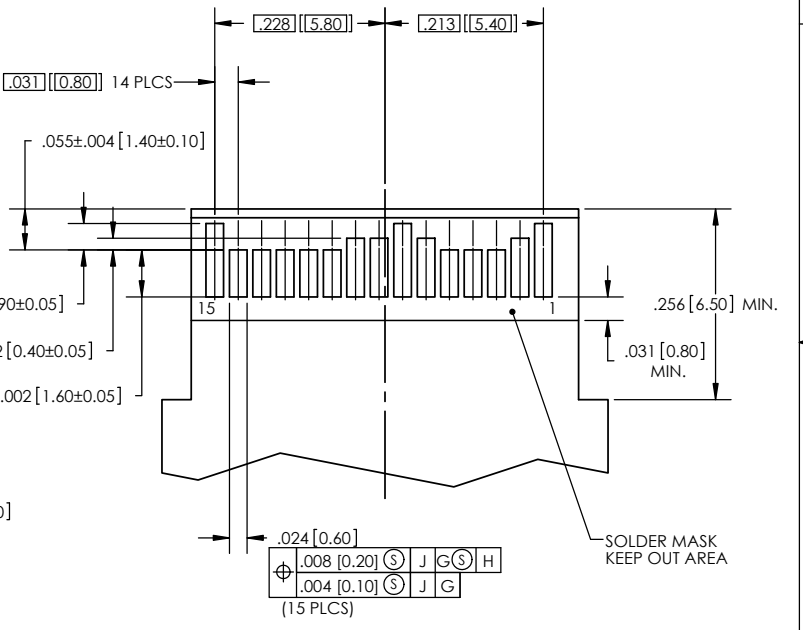

BOTTOM VIEW OF BOARD

DO NOT SCALE DRAWING

THIS DOCUMENT CONTAINS PROPRIETARY INFORMATION AND SUCH INFORMATION MAY NOT BE DISCLOSED TO OTHERS FOR ANY PURPOSE OR USED FOR MANUFACTURING PURPOSES WITHOUT PERMISSION FROM AMPHENOL CANADA CORP.

UNLESS OTHERWISE SPECIFIED DIMENSIONS ARE IN MILLIMETERS TOLERANCES ARE:		APPROVALS		DATE		Amphenol High Speed Interconnects <small>A Division of Amphenol Corp. www.amphenolhighspeed.com</small>			
DECIMALS	ANGLES	DRAWN	J. SI	2005/12/02	TITLE				
		DESIGNED	J. SI	2005/12/02	XFP 30 POSITION HIGH SPEED CONNECTOR RECEPTACLE FIXED BOARD, RIGHT ANGLE SMT				
MATERIAL AND FINISH		CHECKED	X	X					
N/A		QA APPD							
REF.		E APPD			SIZE	DWG. NO.	P-UE75-A30-X000T	REV.	H
CODE IDENT. NO.	03554	DWG APPD			SCALE	NTS	PROJECT	SHEET	3 OF 3

单击下面可查看定价，库存，交付和生命周期等信息

[>>Amphenol\(安费诺\)](#)