

AFCI CONFIDENTIAL

Amphenol
FCI

This document is the property of and embodies CONFIDENTIAL and PROPRIETARY information of AFCI. No part of the information shown on this document may be used in any way or disclosed to others without the written consent of Amphenol AFCI.

CONNECTOR ASSY

- Note
- "n" shows the number of contacts.
 - This product meets European Union Directives and other country regulations as described in GS-22-008
- 注記
- n は極数を示す。
 - 本製品は、GS-22-008に記載されたヨーロッパ連合指令と他国の規制に適合しています。

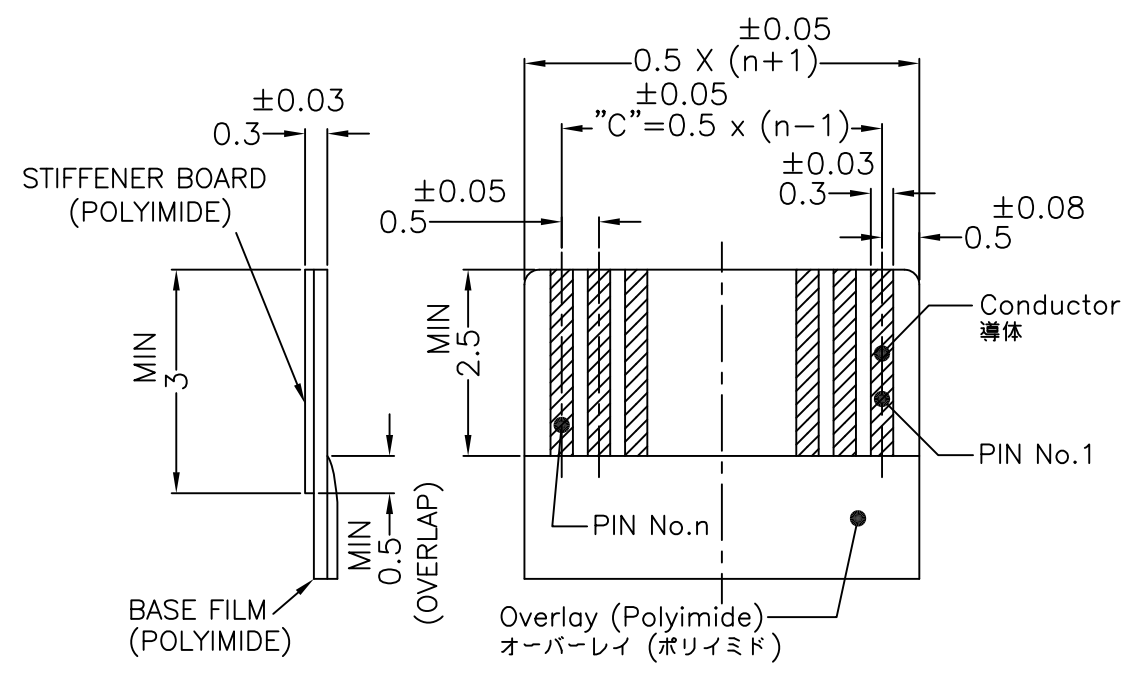
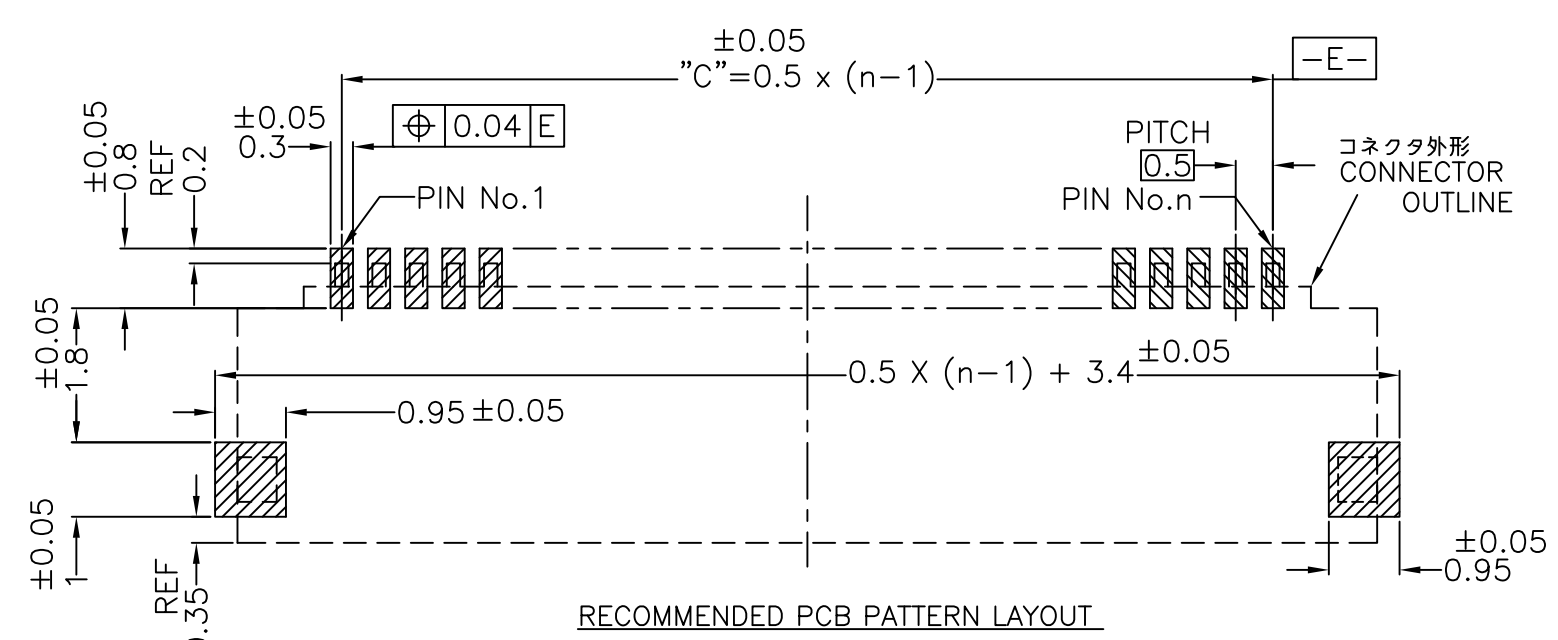
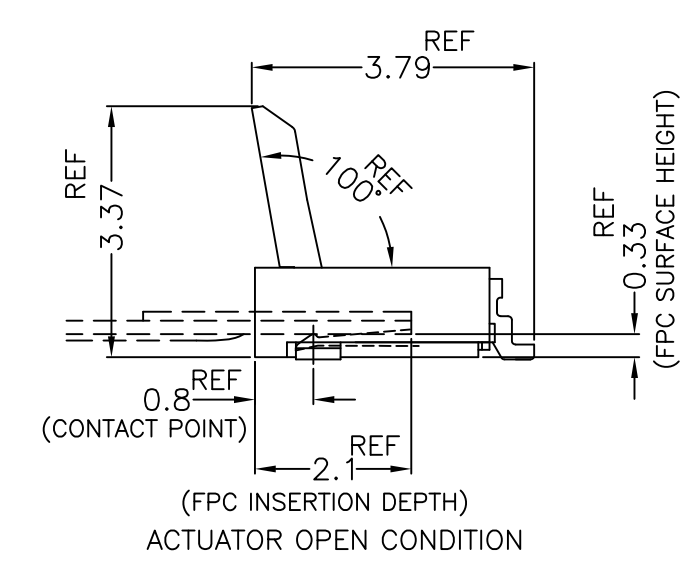
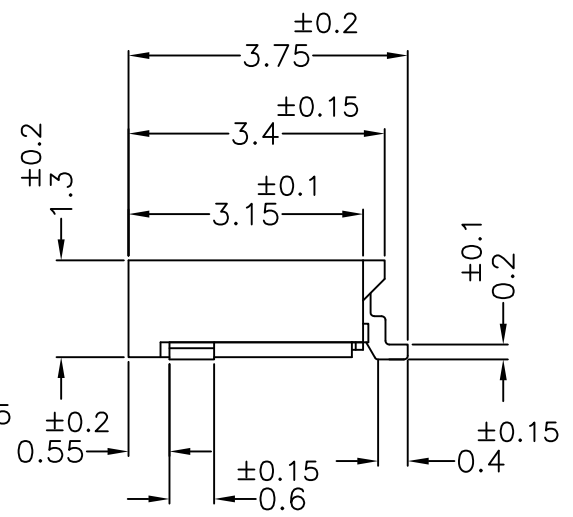
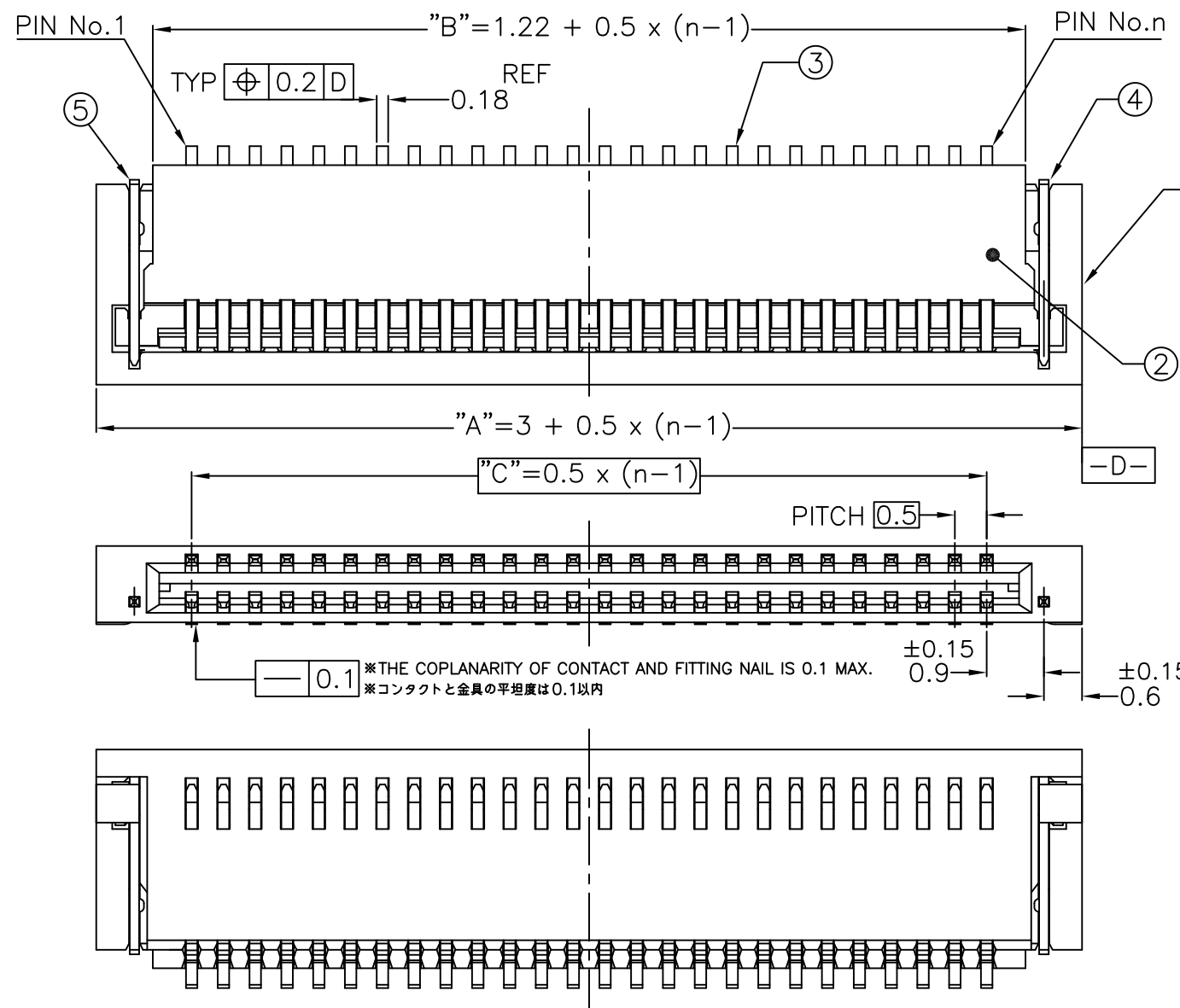

RECOMMENDED FPC PATTERN LAYOUT

mat'l. code				surface		tolerance		projection		product family	
---				ISO 1302		ISO 406		mm		59GF FLEX 0.5	
ltr ecn no dr date				tolerances unless otherwise specified		angles		linear		title	
A	J05-0356	N.S.	6/20/05			±2'		0.X ±0.3		ASSEMBLY	
E	J08-0283	N.S.	2008-7-1					0.XX ±0.3		0.5mm PITCH CONNECTOR FOR FPC VLL Series	
F	J09-0178	N.S.	2009-5-7	dr	N.SASAME	2019-04-12			scale 10:1		dwg no
G	J10-0142	N.S.	2010-6-4	enr	N.SASAME	2019-04-12					sheet 1 of 5
H	J10-0171	N.S.	2010-6-23	chr	THIO_SOON-HOE	2019-04-12					size
J	ELX-J-33203	N.S.	2019-04-12	appd	Y.KAMEDA	2019-04-12					A3
sheet revision										type	
index sheet										Product Customer Drawing	
										Rev.	
										J	

CONNECTOR ASSY

<P/N composition> <P/N 構成>

10051922-24 1 LF

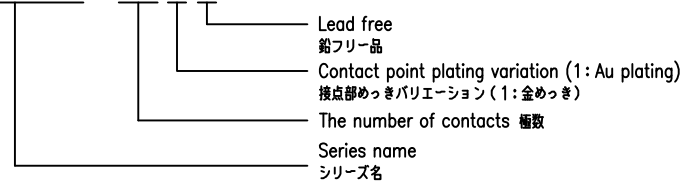

PARTS TABLE 部品表

No.	Part name 部品名	Material 材質	Finish めっき	Note 備考
①	Housing ハウジング	Enter glass fiber LCP resin ガラス繊維入り LCP 樹脂	—	色:乳白色, UL94V-0 Color: Natural, UL94V-0
②	Actuator アクチュエーター	Enter glass fiber 9TPA resin ガラス繊維入り ポリアミド9T	—	色:黒, UL94V-0 Color: Black, UL94V-0
③	Contact コンタクト	Copper alloy 銅合金	Au plating (Nickel underplating) 金めっき(ニッケル下地めっき)	ニッケルダムあり With Ni dam on the contact
④	Fitting nail (Right side) 補強金具(右側)	Copper alloy 銅合金	Tin alloy plating (Nickel underplating) スズ合金めっき(ニッケル下地めっき)	—
⑤	Fitting nail (Left side) 補強金具(左側)	Copper alloy 銅合金	Tin alloy plating (Nickel underplating) スズ合金めっき(ニッケル下地めっき)	—

CONTACT PLATING	DIM "C"	DIM "B"	DIM "A"	⑤ FITTING NAIL(L) QTY	④ FITTING NAIL(R) QTY	③ CONTACT QTY	② ACTUATOR QTY	① HOUSING QTY	PRODUCT NO.
Au	14.5	15.72	17.5	1	1	30	1	1	10051922-301LF
Au	13.5	14.72	16.5	1	1	28	1	1	10051922-281LF
Au	12.5	13.72	15.5	1	1	26	1	1	10051922-261LF
Au	11.5	12.72	14.5	1	1	24	1	1	10051922-241LF
Au	10.5	11.72	13.5	1	1	22	1	1	10051922-221LF
Au	9.5	10.72	12.5	1	1	20	1	1	10051922-201LF
Au	9	10.22	12	1	1	19	1	1	10051922-191LF
Au	8.5	9.72	11.5	1	1	18	1	1	10051922-181LF
Au	7.5	8.72	10.5	1	1	16	1	1	10051922-161LF
Au	7	8.22	10	1	1	15	1	1	10051922-151LF
Au	6.5	7.72	9.5	1	1	14	1	1	10051922-141LF
Au	5.5	6.72	8.5	1	1	12	1	1	10051922-121LF
Au	5	6.22	8	1	1	11	1	1	10051922-111LF
Au	4.5	5.72	7.5	1	1	10	1	1	10051922-101LF
Au	3.5	4.72	6.5	1	1	8	1	1	10051922-081LF

mat'l. code		surface		tolerance		projection		product family	
---		ISO 1302 ✓		ISO 406 ISO 1101				59GF FLEX 0.5	
ltr		ecn no		dr		date		title	
A		J05-0356		N.S		6/20/05		ASSEMBLY	
E		J08-0283		N.S		2008-7-1		0.5mm PITCH CONNECTOR FOR FPC VLL Series	
F		J09-0178		N.S		2009-5-7		dwg no	
G		J10-0142		N.S		2010-6-4		sheet 2 of 5	
H		J10-0171		N.S		2010-6-23		size	
J		ELX-J-33203		N.S		2019-04-12		10051922	
sheet index		revision sheet						A3	
								Product Customer Drawing	
								Rev. J	

CONNECTOR ASSY

HALOGEN FREE

<P/N composition> <P/N 構成>

10051922-24 1 H LF

- Lead free
鉛フリー品
- Halogen free
ハロゲンフリー品
- Contact point plating variation (1: Au plating)
接点部めっきバリエーション(1: 金めっき)
- The number of contacts 極数
- Series name
シリーズ名

PARTS TABLE 部品表

No.	Part name 部品名	Material 材質	Finish めっき	Note 備考
①	Housing ハウジング	Enter glass fiber LCP resin ガラス繊維入り LCP 樹脂	—	色: 乳白色, UL94V-0 Color: Natural, UL94V-0
②	Actuator アクチュエーター	Enter glass fiber LCP resin ガラス繊維入り LCP 樹脂	—	色: 乳白色, UL94V-0 Color: Natural, UL94V-0
③	Contact コンタクト	Copper alloy 銅合金	Au plating (Nickel underplating) 金めっき(ニッケル下地めっき)	ニッケルダムあり With Ni dam on the contact
④	Fitting nail (Right side) 補強金具(右側)	Copper alloy 銅合金	Tin alloy plating (Nickel underplating) スズ合金めっき(ニッケル下地めっき)	—
⑤	Fitting nail (Left side) 補強金具(左側)	Copper alloy 銅合金	Tin alloy plating (Nickel underplating) スズ合金めっき(ニッケル下地めっき)	—

Au	14.5	15.72	17.5	1	1	30	1	1	10051922-301HLF
	13.5	14.72	16.5	1	1	28	1	1	10051922-281HLF
	12.5	13.72	15.5	1	1	26	1	1	10051922-261HLF
	11.5	12.72	14.5	1	1	24	1	1	10051922-241HLF
	10.5	11.72	13.5	1	1	22	1	1	10051922-221HLF
	9.5	10.72	12.5	1	1	20	1	1	10051922-201HLF
	9	10.22	12	1	1	19	1	1	10051922-191HLF
	8.5	9.72	11.5	1	1	18	1	1	10051922-181HLF
	7.5	8.72	10.5	1	1	16	1	1	10051922-161HLF
	7	8.22	10	1	1	15	1	1	10051922-151HLF
	6.5	7.72	9.5	1	1	14	1	1	10051922-141HLF
	5.5	6.72	8.5	1	1	12	1	1	10051922-121HLF
	5	6.22	8	1	1	11	1	1	10051922-111HLF
	4.5	5.72	7.5	1	1	10	1	1	10051922-101HLF
3.5	4.72	6.5	1	1	8	1	1	10051922-081HLF	
CONTACT PLATING	DIM "C"	DIM "B"	DIM "A"	⑤ FITTING NAIL(L) QTY	④ FITTING NAIL(R) QTY	③ CONTACT QTY	② ACTUATOR QTY	① HOUSING QTY	PRODUCT NO.

mat'l. code		surface		tolerance		projection		product family	
---		ISO 1302 <input checked="" type="checkbox"/>		ISO 406				59GF FLEX 0.5	
ltr		ecn no		dr		date		title	
								ASSEMBLY	
								0.5mm PITCH CONNECTOR FOR FPC	
								VLL Series	
								dwg no	
								sheet 3 of 5	
								size	
								A3	
								type	
								Product Customer Drawing	
sheet index		revision sheet						Rev.	
								J	

PRODUCT NO.	DIM "A"	DIM "B"	DIM "C"	DIM "D"	DIM "E"	CONTACT PLATING	Emboss QTY.	TOOLING AVAILABLE							
10051922-0810ELF	16	7.5	21.5	8	--	Au	4500	YES							
10051922-1010ELF								YES							
10051922-1110ELF								YES							
10051922-1210ELF								YES							
10051922-1410ELF								YES							
10051922-1510ELF								YES							
10051922-1610ELF								YES							
10051922-1810ELF								YES							
10051922-1910ELF								YES							
10051922-2010ELF	24	11.5	29.5	8	--	Au	4500	YES							
10051922-2210ELF								YES							
10051922-2410ELF								YES							
10051922-2610ELF								YES							
10051922-2810ELF								YES							
10051922-3010ELF								YES							
10051922-2210ELF								32	14.2	37.5	8	28.4	Au	4500	YES
10051922-2410ELF															YES
10051922-2610ELF															YES
10051922-2810ELF	YES														
10051922-3010ELF	YES														

PARTS TABLE 部品表

No.	Part name 部品名	Material 材質	QTY.	Note 備考
①	The reel for packaging 梱包用リール	Polystyrene ポリスチレン	1	Color : White or Black, Electrification prevention processing 色 : 白または黒、帯電防止処理品
②	Emboss tape エンボステープ	APET or PS	1	Electrification prevention processing 帯電防止処理品
③	Cover tape カバーテープ	POLYESTER, POLYETHYLENE ポリエステル, ポリエチレン	1	
④	Connector コネクタ	See sheet 1	4500	APPLIED FOR 8mm PITCH EMBOS TAPE

EMBOSS PACKAGE

NOTE

- This article carries out the emboss tape package of the 0.5mm pitch connector for FPC.
- The shape and dimension of this article are based on JIS C 0806.
(Taping of electronic parts (Surface mounted device))

注記

- 本品は 0.5mm ピッチ FPC 用コネクタをエンボステープ梱包したものである。
- 本品の形状及び寸法規定は JIS C 0806 (電子部品のテーピング (表面実装部品)) に準拠する。

<P/N composition> <P/N 構成>

10051922-16 1 0E LF

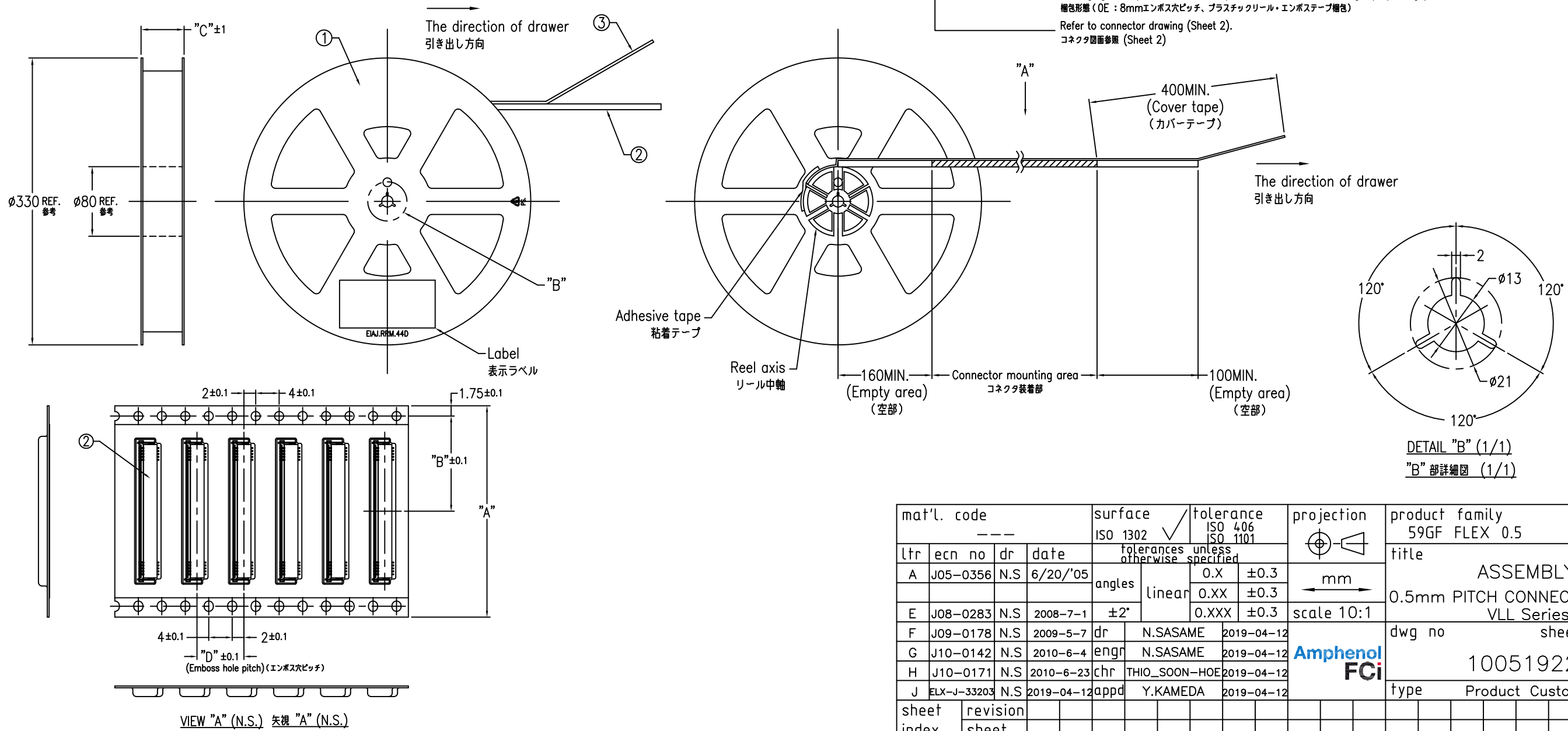

mat'l. code				surface		tolerance		projection		product family	
---				ISO 1302		ISO 406		mm		59GF FLEX 0.5	
ltr	ecn no	dr	date	tolerances unless otherwise specified				title			
A	J05-0356	N.S	6/20/05	angles	linear	0.X	± 0.3	ASSEMBLY			
E	J08-0283	N.S	2008-7-1	$\pm 2'$		0.XX	± 0.3	0.5mm PITCH CONNECTOR FOR FPC			
F	J09-0178	N.S	2009-5-7	dr		0.XXX	± 0.3	VLL Series			
G	J10-0142	N.S	2010-6-4	engr		scale 10:1		dwg no		sheet 4 of 5	size
H	J10-0171	N.S	2010-6-23	chr	THIO_SOON-HOE			10051922			A3
J	ELX-J-33203	N.S	2019-04-12	appd	Y.KAMEDA			type		Product Customer Drawing	Rev.
sheet index	revision sheet									J	

AFCI CONFIDENTIAL

Amphenol FCI

This document is the property of and embodies CONFIDENTIAL and PROPRIETARY information of AFCI. No part of the information shown on this document may be used in any way or disclosed to others without the written consent of Amphenol FCI.

PRODUCT NO.	DIM "A"	DIM "B"	DIM "C"	DIM "D"	DIM "E"	CONTACT PLATING	Emboss QTY.	TOOLING AVAILABLE
10051922-0810EHLF	16	7.5	21.5	8	---	Au	4500	YES
10051922-1010EHLF								YES
10051922-1110EHLF								YES
10051922-1210EHLF								YES
10051922-1410EHLF								YES
10051922-1510EHLF								YES
10051922-1610EHLF								YES
10051922-1810EHLF								YES
10051922-1910EHLF	24	11.5	29.5	8	---	Au	4500	YES
10051922-2010EHLF								YES
10051922-2210EHLF								YES
10051922-2410EHLF								YES
10051922-2610EHLF								YES
10051922-2810EHLF								YES
10051922-3010EHLF								YES
10051922-3010EHLF								32
10051922-2210EHLF	YES							
10051922-2410EHLF	YES							
10051922-2610EHLF	YES							
10051922-2810EHLF	YES							
10051922-3010EHLF	YES							
10051922-3010EHLF	YES							
10051922-3010EHLF	YES							

PARTS TABLE 部品表

No.	Part name 部品名	Material 材質	QTY.	Note 備考
①	The reel for packaging 梱包用リール	Polystyrene ポリスチレン	1	Color : White or Black, Electrification prevention processing 色 : 白または黒、帯電防止処理品
②	Emboss tape エンボステープ	APET or PS	1	Electrification prevention processing 帯電防止処理品
③	Cover tape カバーテープ	POLYESTER, POLYETHYLENE ポリエステル, ポリエチレン	1	
④	Connector コネクタ	See sheet 1	4500	APPLIED FOR 8mm PITCH EMBOS TAPE

EMBOSS PACKAGE

HALOGEN FREE

NOTE

- This article carries out the emboss tape package of the 0.5mm pitch connector for FPC.
- The shape and dimension of this article are based on JIS C 0806.
(Taping of electronic parts (Surface mounted device))

注記

- 本品は 0.5mm ピッチ FPC 用コネクタをエンボステープ梱包したものである。
- 本品の形状及び寸法規定は JIS C 0806 (電子部品のテーピング (表面実装部品)) に準拠する。

<P/N composition> <P/N 構成>

10051922-16 1 0E H LF

- Lead free
鉛フリー品
- Halogen free
ハロゲンフリー品
- Packaging form (0E : 8mm emboss pitch, Plastic reel・Embossing tape package)
梱包形態 (0E : 8mmエンボス穴ピッチ、プラスチックリール・エンボステープ梱包)
- Refer to connector drawing (Sheet 2).
コネクタ図面参照 (Sheet 2)

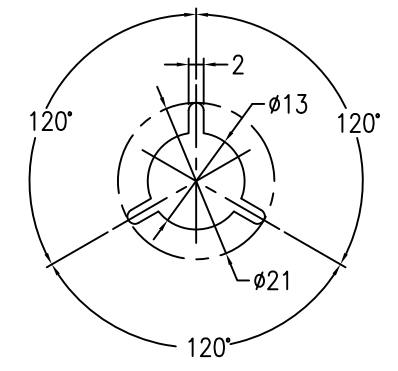
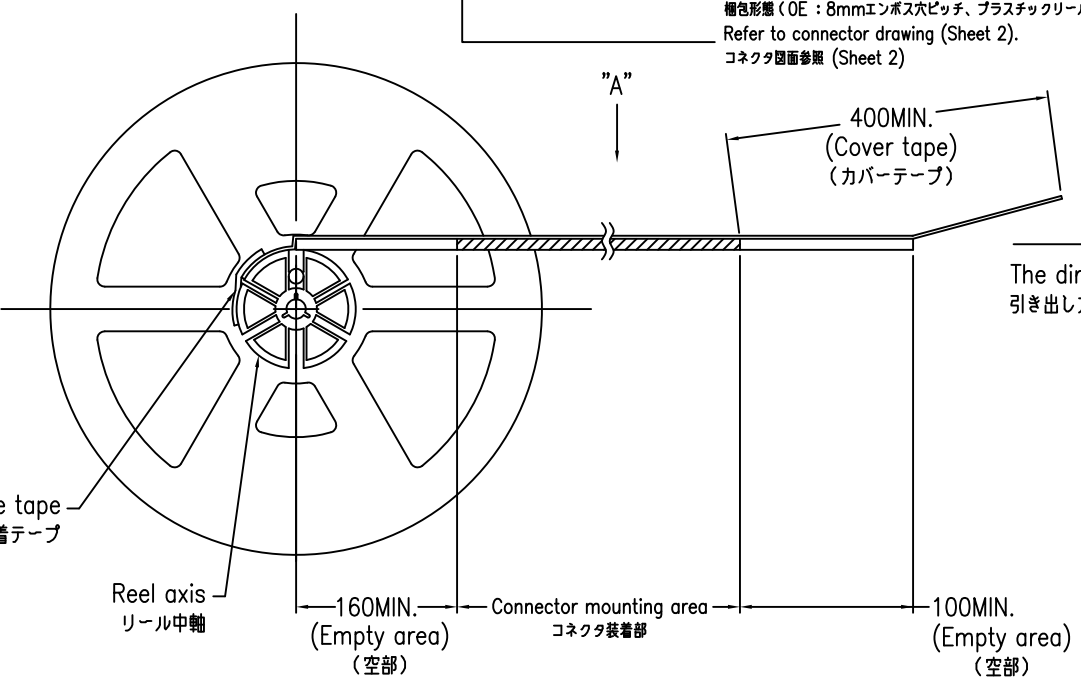
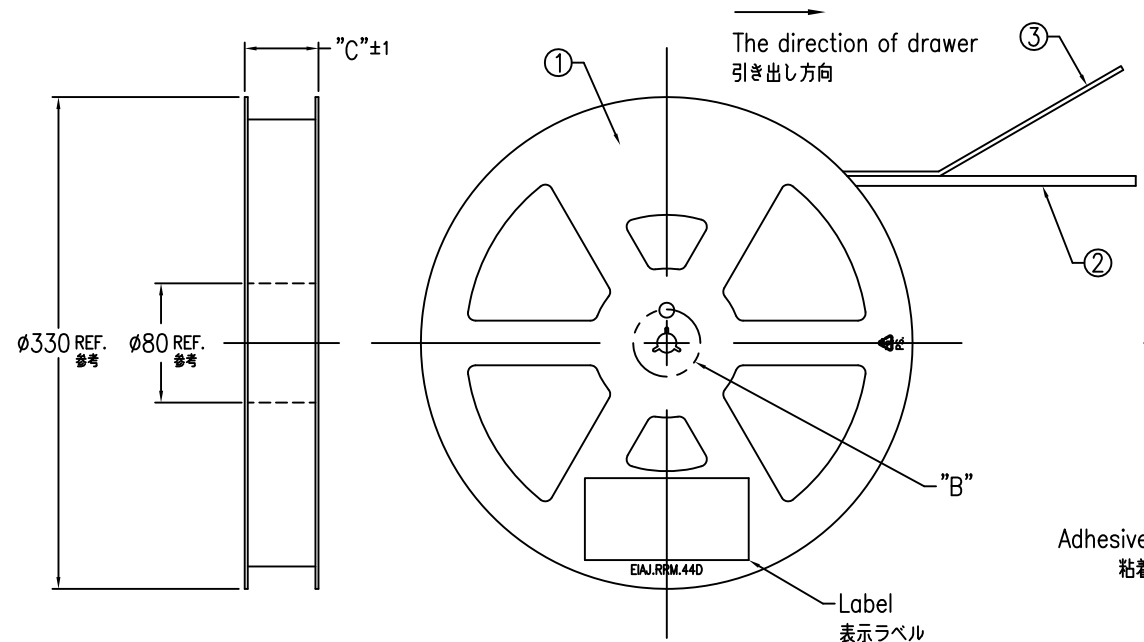

DETAIL "B" (1/1)
"B" 部詳細図 (1/1)

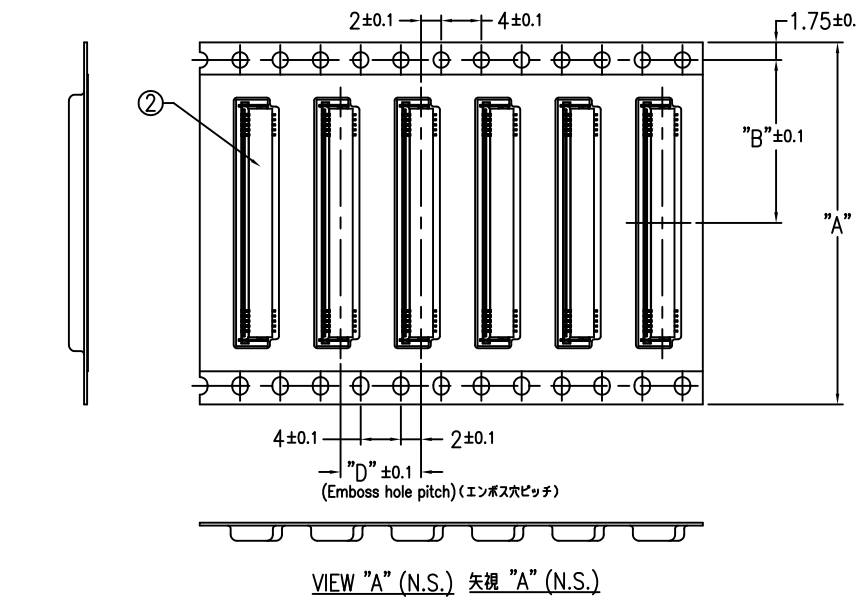

VIEW "A" (N.S.) 矢視 "A" (N.S.)

mat'l. code ---				surface ISO 1302 ✓		tolerance ISO 406 ISO 1101		projection mm		product family 59GF FLEX 0.5			
ltr ecn no dr date				tolerances unless otherwise specified						title ASSEMBLY 0.5mm PITCH CONNECTOR FOR FPC VLL Series			
				angles linear		0.X ±0.3 0.XX ±0.3 0.XXX ±0.3		scale 10:1		dwg no 10051922		sheet 5 of 5 size A3	
				dr		N.SASAME 2019-04-12		Amphenol FCI		type Product Customer Drawing			
G J10-0142 N.S 2010-6-4 engr				N.SASAME 2019-04-12						Rev. J			
H J10-0171 N.S 2010-6-23 chr				THIO_SOON-HOE 2019-04-12									
J ELX-J-33203 N.S 2019-04-12 appd				Y.KAMEDA 2019-04-12									
sheet index				revision sheet									

单击下面可查看定价，库存，交付和生命周期等信息

[>>Amphenol\(安费诺\)](#)