

REVISIONS					
REV	ECO	DESCRIPTION	DATE	BY	APPR
B1	-	RELEASED DRAWING	JUN-25-2014	BEN	TOMMY
B2	-	UPDATING DRAWING	Nov-16-2016	FLAN	TOMMY

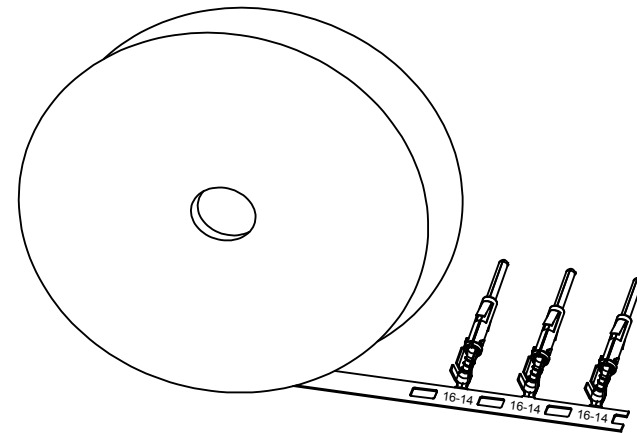

CONTACT ORIENTATION ON ROLL

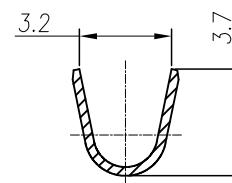

SECTION A-A

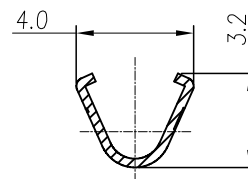

SECTION B-B

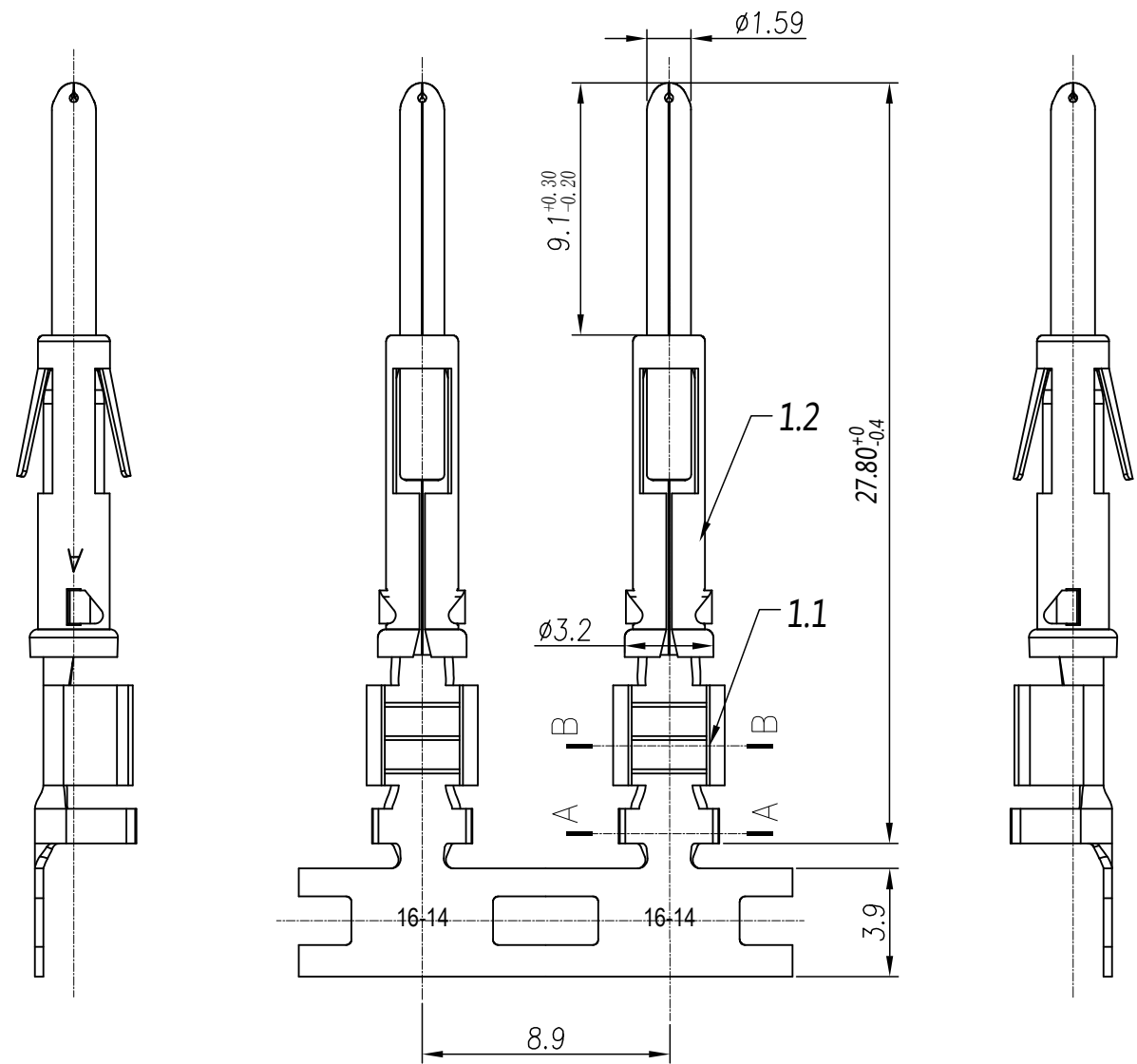

NOTES : (UNLESS OTHERWISE SPECIFIED)

- MATERIAL :
 - CONTACT BODY : COPPER ALLOY.
 - OUTER SPRING : STAINLESS STEEL.
- SPECIFICATIONS :
 - CURRENT RATING : 13A MAX.
 - TERMINATION TYPE : CRIMPING.
 - WIRE RANGE : 14~16AWG.
- RoHS COMPLIANT.
- ALL DIMENSIONS ARE FOR REFERENCE USE ONLY.
- AVAILABLE TOOLS :
 - HAND CRIMPER : MFX-3954.
 - CRIMP APPLICATOR : MFX-3957.
 - EXTRACTION TOOL : QXRT16.

P/N	CONTACT PLATING(MATING AREA)
SP14M1T	TIN PLATING OVER NICKEL.
SP14M1F	GOLD FLASH PLATING OVER NICKEL.
SP14M1G5	5μ" GOLD PLATING OVER NICKEL.
SP14M1G10	10μ" GOLD PLATING OVER NICKEL.
SP14M1G15	15μ" GOLD PLATING OVER NICKEL.
SP14M1G30	30μ" GOLD PLATING OVER NICKEL.

QUANTITY	PART NUMBER	DESCRIPTION	ITEM										
MATERIALS LIST													
UNLESS OTHERWISE SPECIFIED 1) All dimensions are in metric(mm). 2) Tolerances are as follows: 1 PL DEC ±0.30 Fractions ±1/64 2 PL DEC ±0.15 Angles ±1° 3 PL DEC ±0.08 3) Note reference =		<table border="1"> <thead> <tr> <th>SIGNATURES</th> <th>DATE</th> </tr> </thead> <tbody> <tr> <td>DRAWN: FLAN</td> <td>Nov-16-2016</td> </tr> <tr> <td>CHECKED: TOD</td> <td>Nov-16-2016</td> </tr> <tr> <td>ENGINEER:</td> <td></td> </tr> <tr> <td>APPROVAL: TOMMY</td> <td>Nov-16-2016</td> </tr> </tbody> </table>		SIGNATURES	DATE	DRAWN: FLAN	Nov-16-2016	CHECKED: TOD	Nov-16-2016	ENGINEER:		APPROVAL: TOMMY	Nov-16-2016
SIGNATURES	DATE												
DRAWN: FLAN	Nov-16-2016												
CHECKED: TOD	Nov-16-2016												
ENGINEER:													
APPROVAL: TOMMY	Nov-16-2016												
MATERIAL SPECIFICATIONS:		<p style="text-align: center;">Amphenol</p> <p>Sine Systems - www.amphenol-sine.com 44724 Morley Drive Clinton Township, MI 48036</p> <p style="text-align: center;">ECO-MATE, PIN CONTACT, STAMPED, 14-16AWG, SIZE 16</p>											
PROCESS SPECIFICATIONS:													
NEXT ASSY:		<table border="1"> <tr> <td>SIZE</td> <td>TYPE</td> <td>DWG NO:</td> <td>REVISION</td> </tr> <tr> <td>B</td> <td>C-</td> <td>SP14M1XX</td> <td>B2</td> </tr> </table>	SIZE	TYPE	DWG NO:	REVISION	B	C-	SP14M1XX	B2			
SIZE	TYPE	DWG NO:	REVISION										
B	C-	SP14M1XX	B2										
SCALE: NONE		SHEET 1 OF 1											

TITLE: ECO-MATE, PIN CONTACT, STAMPED, 14-16AWG, SIZE 16
DWG NO: SP14M1XX
REV: B2
SH: 1
OF: 1

单击下面可查看定价，库存，交付和生命周期等信息

[>>Amphenol\(安费诺\)](#)