

CONTACT ORIENTATION ON ROLL

NOTES : (UNLESS OTHERWISE SPECIFIED)

1. MATERIAL :
 - 1.1. CONTACT BODY : COPPER ALLOY.
 - 1.2. OUTER SPRING : STAINLESS STEEL.
2. SPECIFICATIONS :
 - 2.1. CURRENT RATING : 23A MAX.
 - 2.2. TERMINATION TYPE : CRIMPING.
 - 2.3. WIRE RANGE : 14~12AWG.
 - 2.4. WIRE INSULATION DIA(MAX) : ϕ 4.3mm.
3. ROHS COMPLIANT.
4. ALL DIMENSIONS ARE FOR REFERENCE USE ONLY.

P/N	CONTACT PLATING(MATING AREA)
SP12A1T	TIN PLATING OVER NICKEL.
SP12A1F	GOLD FLASH PLATING OVER NICKEL.
SP12A1G10	10 μ "GOLD PLATING OVER NICKEL.
SP12A1G15	15 μ "GOLD PLATING OVER NICKEL.
SP12A1G30	30 μ "GOLD PLATING OVER NICKEL.

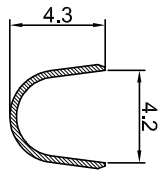

SECTION B-B

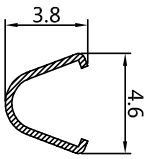

SECTION A-A

REVISIONS					
REV	ECO	DESCRIPTION	DATE	BY	APPR
B1	-	RELEASED DRAWING	JAN-18-2014	ARROW	TOMMY
B2	-	UPDATE DRAWING	NOV-09-2016	FLAN	TOMMY

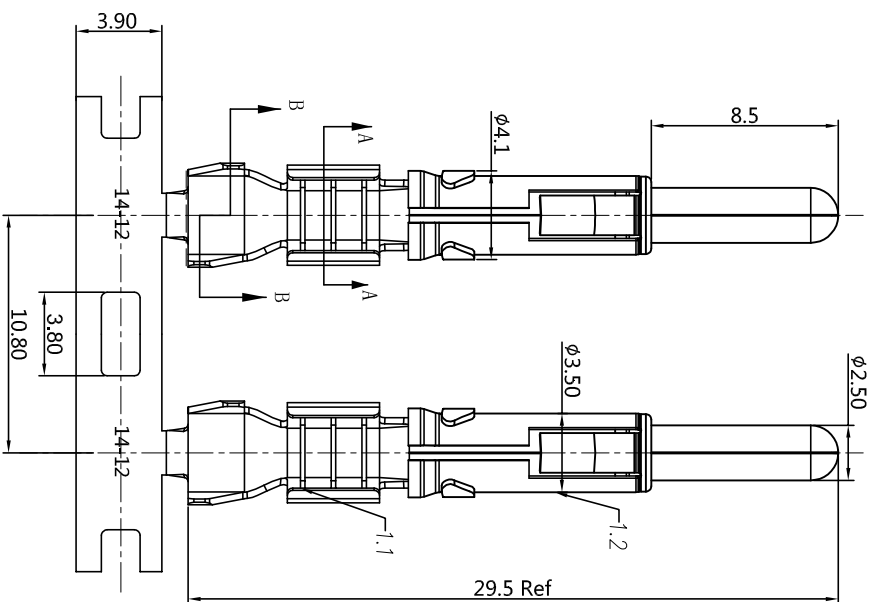

QUANTITY	PART NUMBER	DESCRIPTION	ITEM

UNLESS OTHERWISE SPECIFIED			
1) All dimensions are in millimeters.	DRAWN	DATE	
2) Tolerances are as follows:	FLN	NOV-09-2016	
1 PL DEC 20-09	FRACIONS: 1/16"	ENGINEER	NOV-09-2016
3 PL DEC 20-09	ANGLES: 1°	APPROVAL:	TOMMY
3) Note reference = Δ	CUSTOMER:	NOV-09-2016	
MATERIAL SPECIFICATIONS:			
PROCESS SPECIFICATIONS:			
TESTING SPECIFICATIONS:			
REVISIONS:			
SCALE: NONE	SIZE: B	TYPE: C-	DWG NO: SP12A1XX
REVISION: B2			

Amphenol
 Site Systems - www.amphenol-site.com
 44724 Morley Drive
 Clinton Township, MI 48036

ECO-MATE PIN CONTACT,
 STAMPED, 14-12AWG, 2.5mm CONTACT

单击下面可查看定价，库存，交付和生命周期等信息

[>>Amphenol\(安费诺\)](#)