

General Description

The AOZ8671BDT-05 is a single channel transient voltage suppressor designed to protect high speed data lines and voltage sensitive electronics from high transient conditions and ESD.

This device incorporates one bidirectional TVS diode in an ultra-small 0201 footprint package. It may be used to meet the ESD immunity requirements of IEC 61000-4-2, Level 4 (± 15 kV air, ± 8 kV contact discharge).

The AOZ8671BDT-05 comes in an RoHS compliant package and is rated over a -40°C to $+125^{\circ}\text{C}$ ambient temperature range.

The ultra-small 0.6 mm x 0.3 mm 0201 footprint package makes the AOZ8671BDT-05 ideal for applications where PCB space is a premium. The small size and high ESD protection makes it ideal for protecting voltage sensitive electronics from high transient conditions and ESD.

Features

- ESD protection for high-speed data lines:
 - IEC 61000 IE-4-2, ESD immunity:
 - Air discharge: ± 30 kV;
 - Contact Discharge: ± 30 kV;
 - IEC 61000-4-5 (Lightning) 7A (8/20 μs)
 - Human Body Mode: ± 30 kV
- Bidirectional TVS
- Low capacitance: 1 pF
- Low clamping voltage
- Low operating voltage: 5.5 V

Applications

- Mobile phones
- Notebook computers
- Portable devices



Typical Application

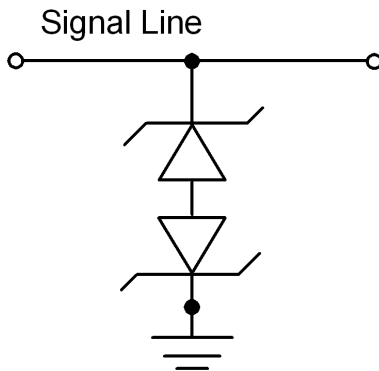

Pin Configuration

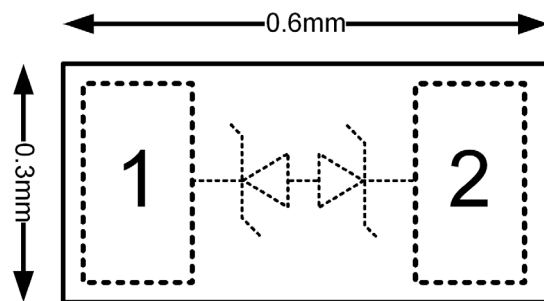

Ordering Information

Part Number	Ambient Temperature Range	Package	Environmental
AOZ8671BDT-05	-40°C to +125°C	DFN 0.6 x 0.3 A_2L	Green Product



AOS Green Products use reduced levels of Halogens, and are also RoHS compliant. Please visit www.aosmd.com/media/AOSGreenPolicy.pdf for additional information.

Absolute Maximum Ratings

Exceeding the Absolute Maximum Ratings may damage the device.

Parameter	Rating
Any Pin to Pin	5.5 V
Peak Pulse Current (I_{PP}), $t_P = 8/20 \mu s$	7 A
Peak Pulse Power (P_{PP}), $t_P = 8/20 \mu s$	45 W
Storage Temperature (T_S)	-65°C to +150°C
ESD Rating per IEC61000-4-2, Contact ⁽¹⁾	±30 kV
ESD Rating per IEC61000-4-2, Air ⁽¹⁾	±30 kV
ESD Rating per Human Body Mode ⁽²⁾	±30 kV

Notes:

- IEC 61000-4-2 discharge with $C_{Discharge} = 150 \text{ pF}$, $R_{Discharge} = 330 \Omega$.
- Human Body Discharge per MIL-STD-883, Method 3015 $C_{Discharge} = 100 \text{ pF}$, $R_{Discharge} = 1.5 \text{ k}\Omega$

Maximum Operating Conditions

The device is not guaranteed to operate beyond the Maximum Operating Conditions.

Parameter	Rating
Junction Temperature (T_J)	-40°C to +125°C

Electrical Characteristics

T_A = 25°C unless otherwise specified.

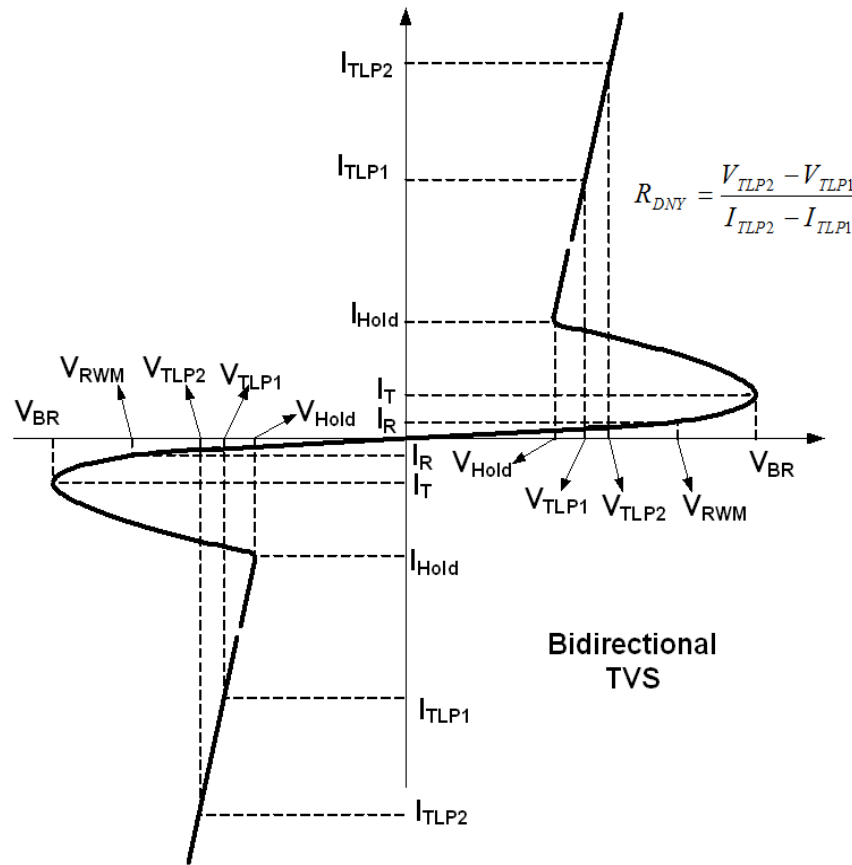

Symbol	Parameter	Conditions	Min.	Typ.	Max.	Units
V _{RWM}	Reverse Working Voltage				5.5	V
V _{BR}	Reverse Breakdown Voltage	I _T = 10 μA	6	10	12	V
I _R	Reverse Leakage Current	Max. V _{RWM}		1	50	nA
V _{CL}	Clamping Voltage ⁽³⁾⁽⁴⁾ (100ns Transmission Line Pulse)	I _{TLP} = 1 A		3.5		V
		I _{TLP} = 16 A		8		
	Clamping Voltage ⁽³⁾ (IEC61000-4-5, 8/20 μs)	I _{PP} = 1 A		3.5		
		I _{PP} = 7 A		6.5		
R _{DNY}	Dynamic Resistance ⁽³⁾⁽⁴⁾	I _{TLP} = 1 A to 16 A		0.3		Ω
C _J	Junction Capacitance	V _{I/O} = 0 V, f = 1 MHz		1	1.2	pF

Notes:

- 3. These specifications are guaranteed by design and characterization.
- 4. Measurements performed using a 100ns Transmission Line Pulse (TLP) system.

Typical Performance Characteristics

Positive TLP Curve
($t_p = 100\text{ns}$, $t_r = 0.2\text{ns}$)

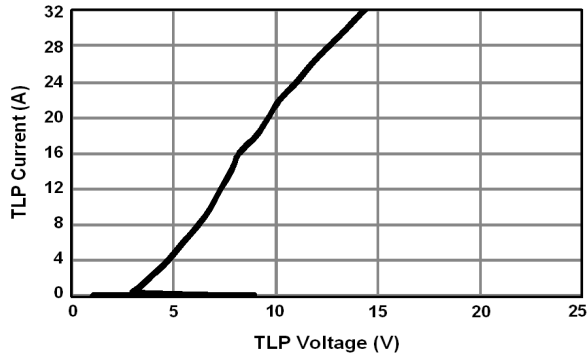

Negative TLP Curve
($t_p = 100\text{ns}$, $t_r = 0.2\text{ns}$)

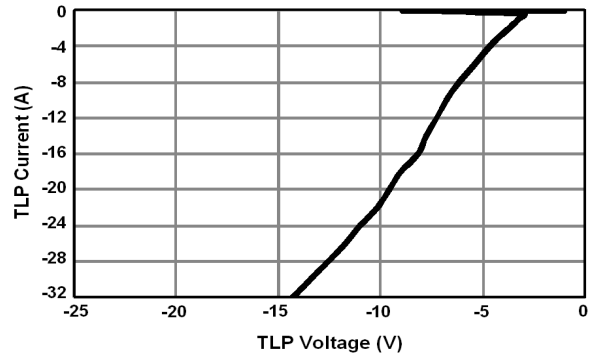

Typical Variations of CJ vs. Input Voltage

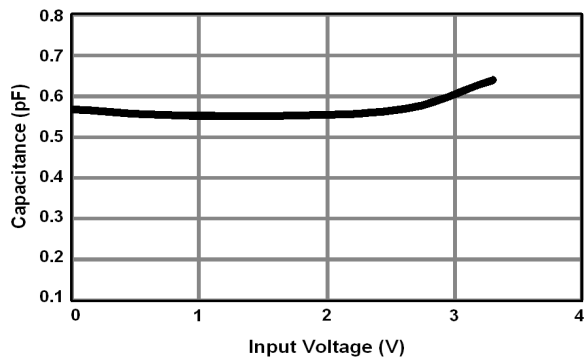

IEC61000-4-5 Surge 8/20 μs

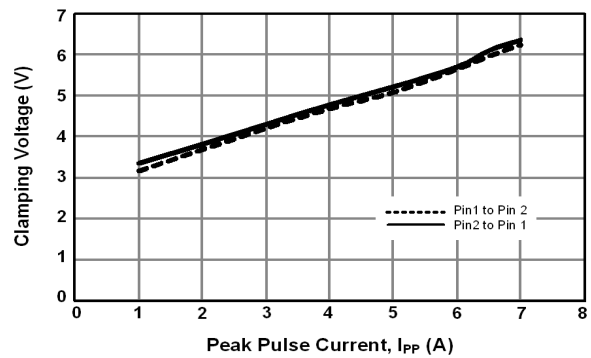

**+8kV ESD Clamping Per IEC 61000-4-2
(Contact, Any I/O to I/O Pin)**

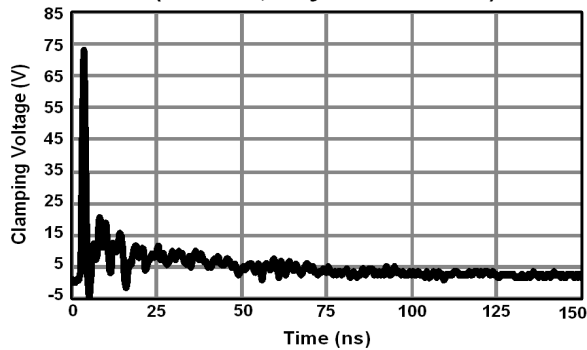

**-8kV ESD Clamping Per IEC 61000-4-2
(Contact, Any I/O to I/O Pin)**

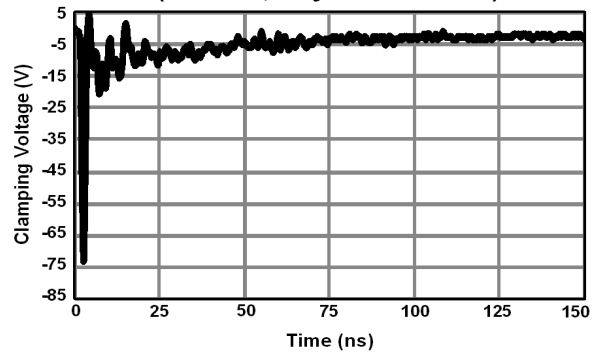

Package Dimensions, DFN 0.6x0.3A_2L,EP2

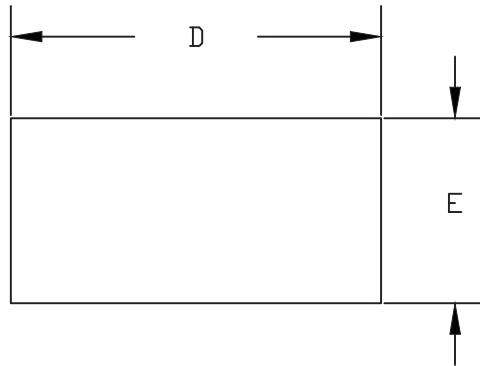

Top View

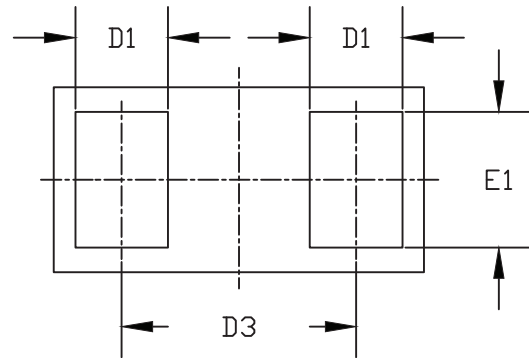

Bottom View

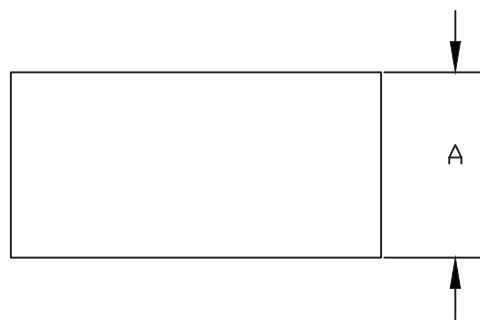

Side View

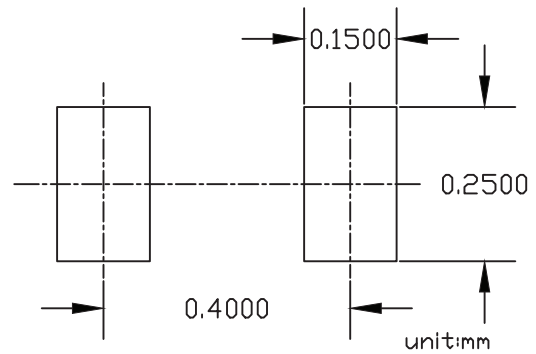

RECOMMEND LAND PATTERN

SYMBOLS	DIMENSIONS IN MILLIMETERS			DIMENSIONS IN INCHES		
	MIN	NOM	MAX	MIN	NOM	MAX
A	0.285	0.30	0.315	0.0112	0.0118	0.0124
D	0.575	0.60	0.625	0.0226	0.0236	0.0246
D1	0.12	0.15	0.18	0.0047	0.0059	0.0071
D2	0.20	0.25	0.30	----	0.0102	----
D3	---	0.38	---	----	0.0150	----
E	0.275	0.30	0.325	0.0108	0.0118	0.0128
E1	0.19	0.22	0.25	0.0075	0.0087	0.0098

NOTE

1. ALL DIMENSIONS ARE IN MILLIMETERS.
2. DIMENSIONS ARE INCLUSIVE OF PLATING.
3. PACKAGE BODY SIZES EXCLUDE MOLD FLASH AND GATE BURRS.
MOLD FLASH AT THE NON-LEAD SIDES SHOULD BE LESS THAN 6MIL EACH.
4. CONTROLLING DIMENSION IS MILLIMETER. CONVERTED INCH DIMENSIONS ARE NOT NECESSARILY EXACT.
5. PADDLE EXPOSED ON BOTTOM.

Tape and Reel Dimensions, DFN 0.6x0.3A_2L_EP2_S

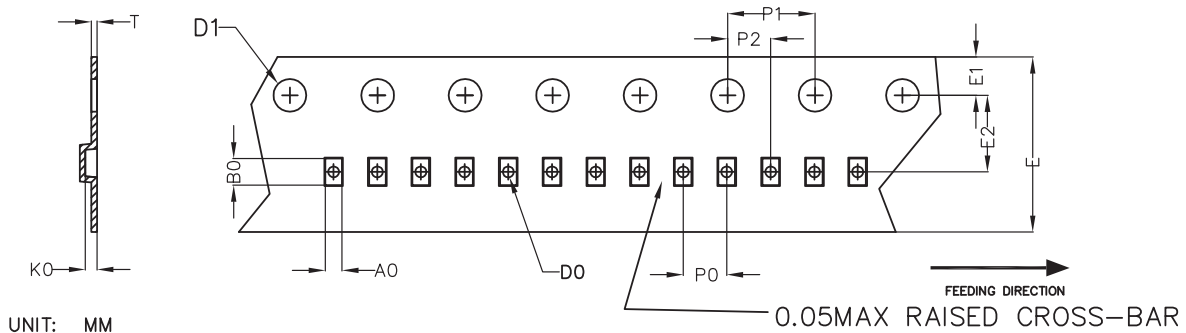

UNIT: MM

PACKAGE	A0	B0	K0	D0	D1	E	E1	E2	P0	P1	P2	T
DFN0.6x0.3A_2L_EP2_S (8 MM)	0.36 ±0.03	0.68 ±0.03	0.33 ±0.03	0.20 ±0.05	1.50 +0.10	8.00 ±0.10	1.75 ±0.10	3.50 ±0.05	2.00 ±0.10	4.00 ±0.10	2.00 ±0.05	0.20 ±0.02

DFN0.6x0.3A 2L EP2 S
REEL

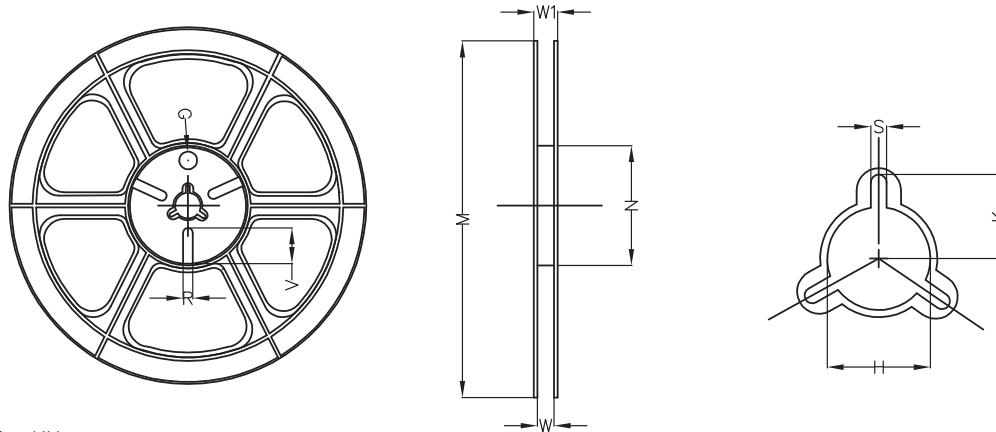

UNIT: MM

TAPE SIZE	REEL SIZE	M	N	W	W1	H	K	S	G	R	V
8 mm	ø178	ø178.00 ±1.00	ø54.00 ±0.50	9.00 ±0.30	11.40 ±1.00	ø13.00 +0.50 -0.20	10.60	2.00 ±0.50	ø9.00	5.00	18.00

DFN0.6x0.3A 2L EP2 S TAPE

Leader / Trailer
& Orientation

Unit Per Reel:
15000pcs

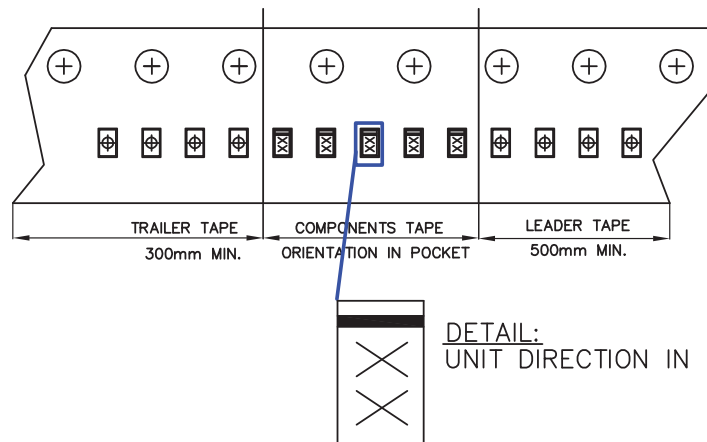

DETAIL:
UNIT DIRECTION IN POCKET

Part Marking

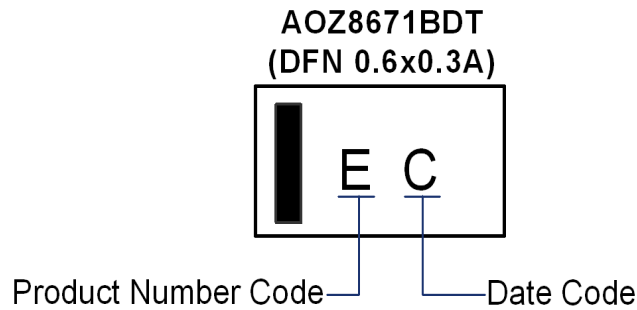

LEGAL DISCLAIMER

Alpha and Omega Semiconductor makes no representations or warranties with respect to the accuracy or completeness of the information provided herein and takes no liabilities for the consequences of use of such information or any product described herein. Alpha and Omega Semiconductor reserves the right to make changes to such information at any time without further notice. This document does not constitute the grant of any intellectual property rights or representation of non-infringement of any third party's intellectual property rights.

LIFE SUPPORT POLICY

ALPHA AND OMEGA SEMICONDUCTOR PRODUCTS ARE NOT AUTHORIZED FOR USE AS CRITICAL COMPONENTS IN LIFE SUPPORT DEVICES OR SYSTEMS.

As used herein:

- | | |
|---|---|
| <p>1. Life support devices or systems are devices or systems which, (a) are intended for surgical implant into the body or (b) support or sustain life, and (c) whose failure to perform when properly used in accordance with instructions for use provided in the labeling, can be reasonably expected to result in a significant injury of the user.</p> | <p>2. A critical component in any component of a life support, device, or system whose failure to perform can be reasonably expected to cause the failure of the life support device or system, or to affect its safety or effectiveness.</p> |
|---|---|

单击下面可查看定价，库存，交付和生命周期等信息

[>>AOS\(万代\)](#)