

General Description

The AON1605 utilize advanced trench MOSFET technology in small DFN 1.0 x 0.6 package. This device is ideal for load switch applications.

Product Summary

V_{DS}	-20V
I_D (at $V_{GS}=-4.5V$)	-0.7A
$R_{DS(ON)}$ (at $V_{GS}=-4.5V$)	< 710m Ω
$R_{DS(ON)}$ (at $V_{GS}=-2.5V$)	< 930m Ω
$R_{DS(ON)}$ (at $V_{GS}=-1.8V$)	< 1250m Ω

Typical ESD protection

HBM Class 1C

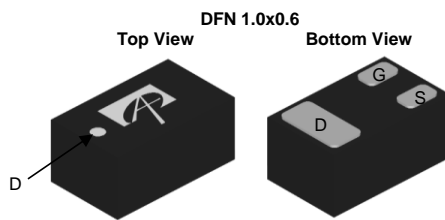

Absolute Maximum Ratings $T_A=25^\circ\text{C}$ unless otherwise noted

Parameter	Symbol	Maximum	Units
Drain-Source Voltage	V_{DS}	-20	V
Gate-Source Voltage	V_{GS}	± 8	V
Continuous Drain Current ^E	I_D	$T_A=25^\circ\text{C}$	-0.7
		$T_A=70^\circ\text{C}$	-0.55
Pulsed Drain Current ^C	I_{DM}	-2	A
Power Dissipation ^A	P_D	$T_A=25^\circ\text{C}$	0.9
		$T_A=70^\circ\text{C}$	0.55
Junction and Storage Temperature Range	T_J, T_{STG}	-55 to 150	$^\circ\text{C}$

Thermal Characteristics

Parameter	Symbol	Typ	Max	Units
Maximum Junction-to-Ambient ^A $t \leq 10\text{s}$	$R_{\theta JA}$	80	100	$^\circ\text{C/W}$
Maximum Junction-to-Ambient ^A Steady-State		110	140	$^\circ\text{C/W}$
Maximum Junction-to-Ambient ^B $t \leq 10\text{s}$	$R_{\theta JA}$	200	245	$^\circ\text{C/W}$
Maximum Junction-to-Ambient ^B Steady-State		280	340	$^\circ\text{C/W}$

Electrical Characteristics (T_J=25°C unless otherwise noted)

Symbol	Parameter	Conditions	Min	Typ	Max	Units
STATIC PARAMETERS						
BV _{DSS}	Drain-Source Breakdown Voltage	I _D =-250μA, V _{GS} =0V	-20			V
I _{DSS}	Zero Gate Voltage Drain Current	V _{DS} =-20V, V _{GS} =0V T _J =55°C			-1 -5	μA
I _{GSS}	Gate-Body leakage current	V _{DS} =0V, V _{GS} =±8V			±10	μA
V _{GS(th)}	Gate Threshold Voltage	V _{DS} =V _{GS} , I _D =-250μA	-0.4	-0.7	-1.1	V
I _{D(ON)}	On state drain current	V _{GS} =-4.5V, V _{DS} =-5V	-2			A
R _{DS(ON)}	Static Drain-Source On-Resistance	V _{GS} =-4.5V, I _D =-0.4A T _J =125°C		590	710	mΩ
				835	1010	
		V _{GS} =-2.5V, I _D =-0.3A		745	930	mΩ
		V _{GS} =-1.8V, I _D =-0.2A		955	1250	mΩ
		V _{GS} =-1.5V, I _D =-0.1A		1115		mΩ
g _{FS}	Forward Transconductance	V _{DS} =-5V, I _D =-0.4A		1		S
V _{SD}	Diode Forward Voltage	I _S =-0.4A, V _{GS} =0V		-0.85	-1.2	V
I _S	Maximum Body-Diode Continuous Current ^E				-0.7	A
DYNAMIC PARAMETERS						
C _{iss}	Input Capacitance	V _{GS} =0V, V _{DS} =-10V, f=1MHz		50		pF
C _{oss}	Output Capacitance			12		pF
C _{riss}	Reverse Transfer Capacitance			7.5		pF
R _g	Gate resistance	V _{GS} =0V, V _{DS} =0V, f=1MHz		45		Ω
SWITCHING PARAMETERS						
Q _g	Total Gate Charge	V _{GS} =-4.5V, V _{DS} =-10V, I _D =-0.4A		0.75		nC
Q _{gs}	Gate Source Charge			0.15		nC
Q _{gd}	Gate Drain Charge			0.2		nC
t _{D(on)}	Turn-On DelayTime	V _{GS} =-4.5V, V _{DS} =-10V, R _L =25Ω, R _{GEN} =3Ω		6		ns
t _r	Turn-On Rise Time			5		ns
t _{D(off)}	Turn-Off DelayTime			22		ns
t _f	Turn-Off Fall Time			8		ns

A: The value of R_{θJA} is measured with the device mounted on 1in² FR-4 board with 2oz. Copper, in a still air environment with T_A=25° C. The Power dissipation P_{DSM} is based on R_{θJA} and the maximum allowed junction temperature of 150° C. The value in any given application depends on the user's specific board design, and the maximum temperature of 150° C may be used if the PCB allows it to.

B: The value of R_{θJA} is measured with the device mounted on FR-4 minimum pad board, in a still air environment with T_A=25° C. The Power dissipation P_{DSM} is based on R_{θJA} and the maximum allowed junction temperature of 150° C. The value in any given application depends on the user's specific board design, and the maximum temperature of 150° C may be used if the PCB allows it to.

C: The static characteristics in Figures 1 to 6 are obtained using <300 μs pulses, duty cycle 0.5% max.

D: These tests are performed with the device mounted on 1 in² FR-4 board with 2oz. Copper, in a still air environment with T_A=25° C. The SOA curve provides a single pulse rating.

E: The maximum current limited by package.

THIS PRODUCT HAS BEEN DESIGNED AND QUALIFIED FOR THE CONSUMER MARKET. APPLICATIONS OR USES AS CRITICAL COMPONENTS IN LIFE SUPPORT DEVICES OR SYSTEMS ARE NOT AUTHORIZED. AOS DOES NOT ASSUME ANY LIABILITY ARISING OUT OF SUCH APPLICATIONS OR USES OF ITS PRODUCTS. AOS RESERVES THE RIGHT TO IMPROVE PRODUCT DESIGN, FUNCTIONS AND RELIABILITY WITHOUT NOTICE.

TYPICAL ELECTRICAL AND THERMAL CHARACTERISTICS

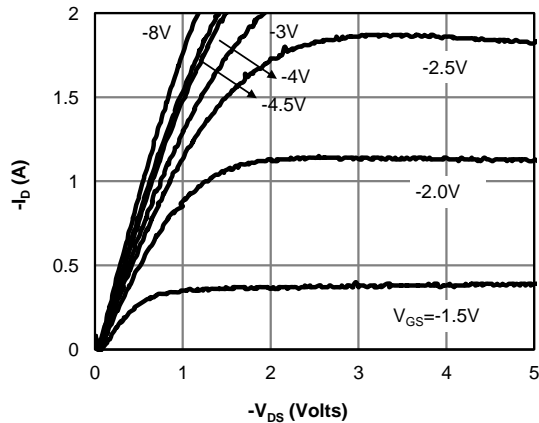

Fig 1: On-Region Characteristics (Note E)

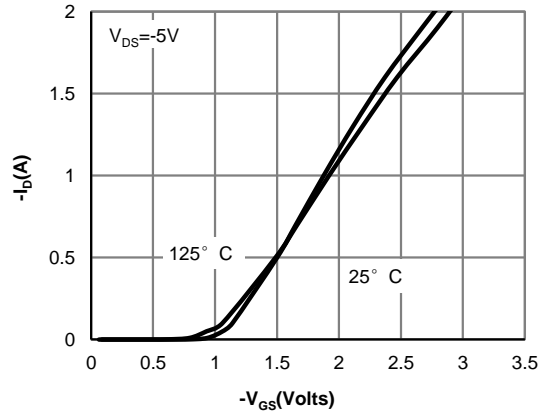

Figure 2: Transfer Characteristics (Note E)

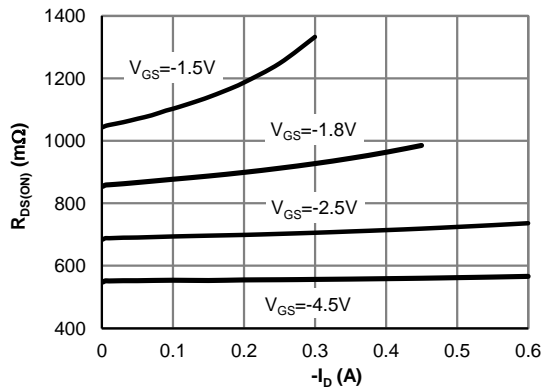

Figure 3: On-Resistance vs. Drain Current and Gate Voltage (Note E)

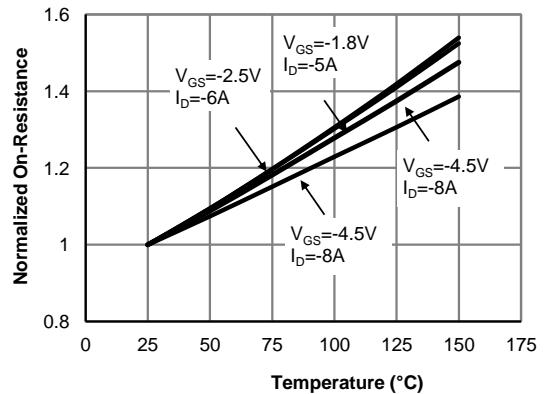

Figure 4: On-Resistance vs. Junction Temperature (Note E)

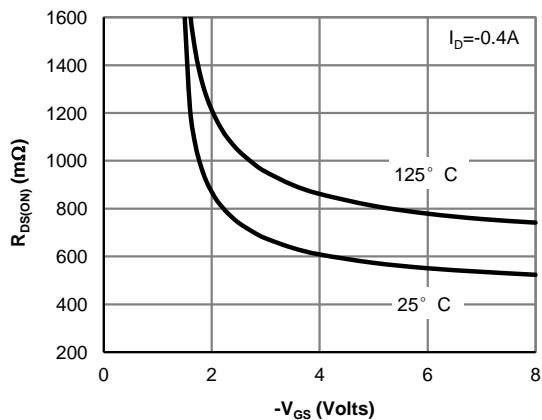

Figure 5: On-Resistance vs. Gate-Source Voltage (Note E)

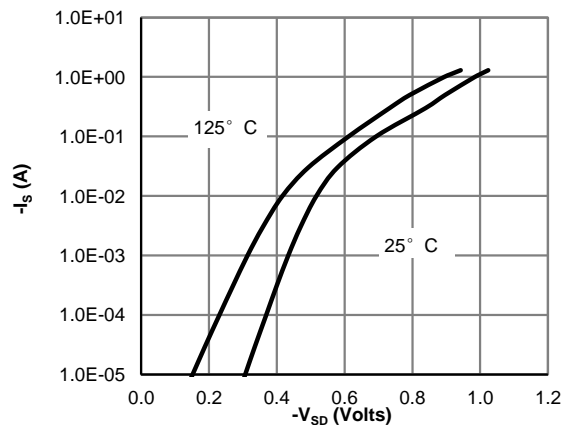

Figure 6: Body-Diode Characteristics (Note E)

TYPICAL ELECTRICAL AND THERMAL CHARACTERISTICS

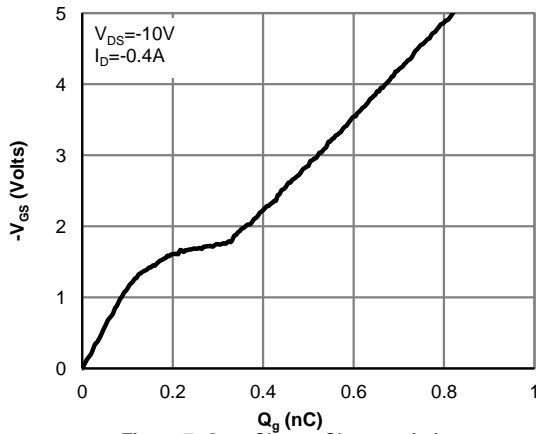

Figure 7: Gate-Charge Characteristics

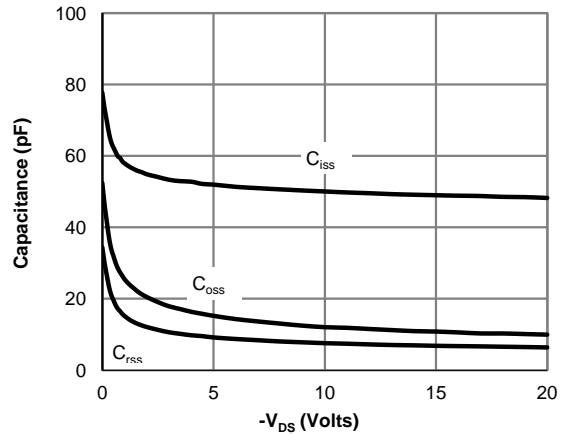

Figure 8: Capacitance Characteristics

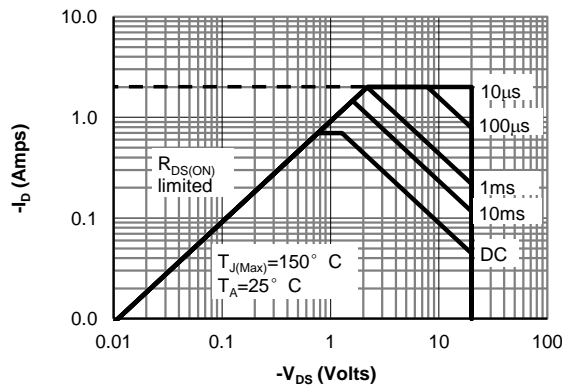

Figure 9: Maximum Forward Biased Safe Operating Area (Note B)

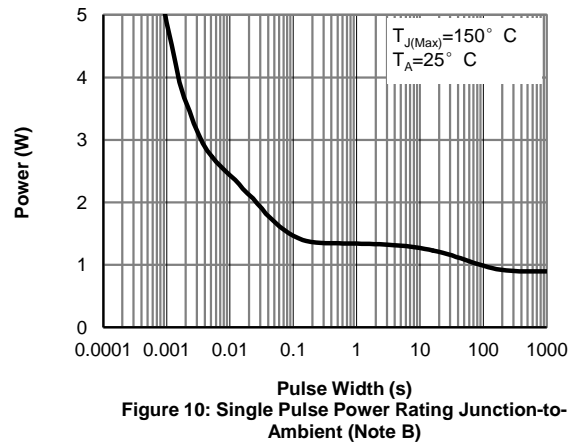

Figure 10: Single Pulse Power Rating Junction-to-Ambient (Note B)

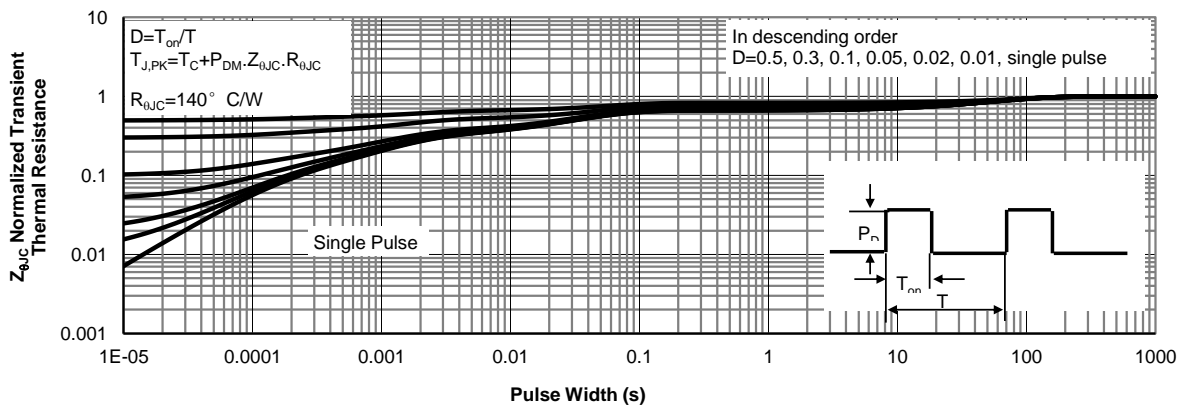
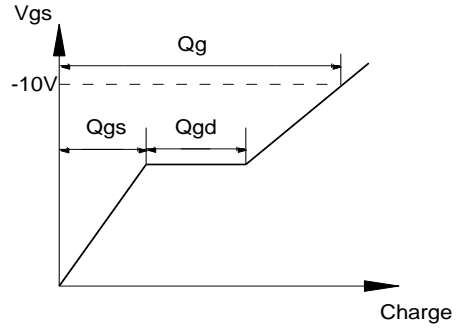
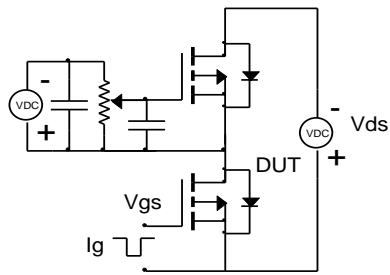
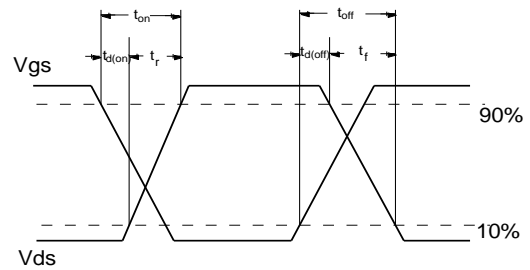
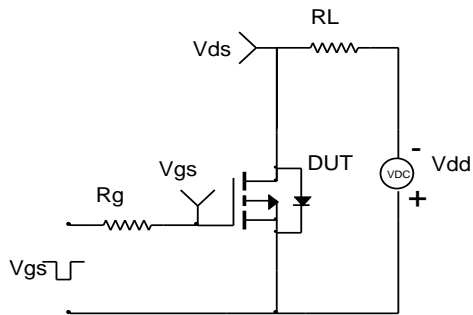

Figure 11: Normalized Maximum Transient Thermal Impedance (Note B)

Gate Charge Test Circuit & Waveform



Resistive Switching Test Circuit & Waveforms



单击下面可查看定价，库存，交付和生命周期等信息

[>>AOS\(万代\)](#)