

## General Description

The AOZ3019 is a high efficiency, easy to use, 6A synchronous buck regulator. The AOZ3019 works from 4.5V to 18V input voltage range, and provides up to 6A of continuous output current with an output voltage adjustable down to 0.8V.

The AOZ3019 comes in a DFN5x6 package and is rated over a -40°C to +85°C operating ambient temperature range.

## Features

- 4.5V to 18V operating input voltage range
- Synchronous Buck: 30mΩ internal high-side switch and 15mΩ internal low-side switch (at 12V)
- Up to 95% efficiency
- External soft start
- Output voltage adjustable to 0.8V
- 6A continuous output current
- 500kHz PWM operation
- Cycle-by-cycle current limit
- Pre-bias start-up
- Short-circuit protection
- Thermal shutdown
- DFN5x6 package

## Applications

- Point of load DC/DC converters
- LCD TV
- Set top boxes
- DVD and Blu-ray players/recorders
- Cable modems



## Typical Application

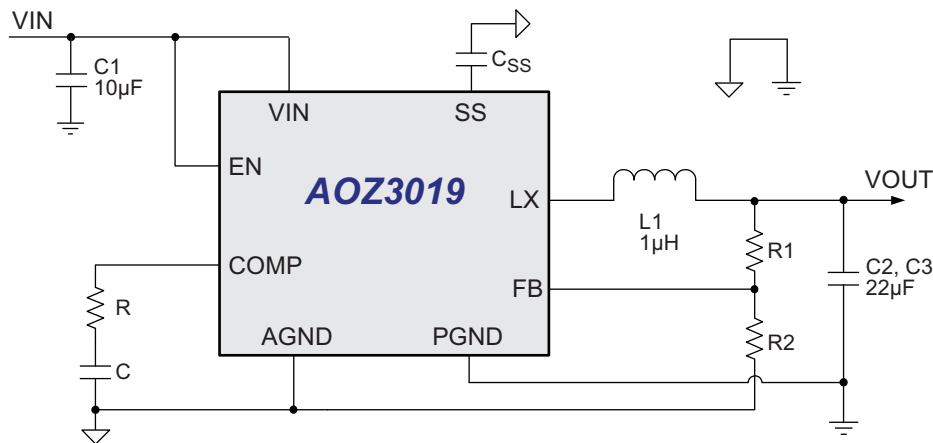

Figure 1. 1.05V, 6A Synchronous Buck Regulator,  $F_s = 500\text{kHz}$

## Ordering Information

Part Number	Ambient Temperature Range	Package	Environmental
AOZ3019DI	-40°C to +85°C	DFN5x6	Green Product



AOS Green Products use reduced levels of Halogens, and are also RoHS compliant.

Please visit [www.aosmd.com/media/AOSGreenPolicy.pdf](http://www.aosmd.com/media/AOSGreenPolicy.pdf) for additional information.

## Pin Configuration

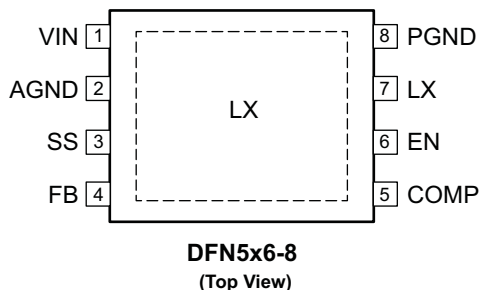

## Pin Description

Pin Number	Pin Name	Pin Function
1	VIN	Supply voltage input. When VIN rises above the UVLO threshold and EN is logic high, the device starts up.
2	AGND	Analog ground. AGND is the reference point for controller section. AGND needs to be electrically connected to PGND.
3	SS	Soft-start pin. 5µA current charging current.
4	FB	Feedback input. The FB pin is used to set the output voltage via a resistive voltage divider between the output and AGND.
5	COMP	External loop compensation pin. Connect a RC network between COMP and AGND to compensate the control loop.
6	EN	Enable pin. Pull EN to logic high to enable the device. Pull EN to logic low to disable the device. If on/off control is not needed, connect EN to VIN and do not leave it open.
7	LX	Switching node. LX is the drain of the internal power PFET.
8	PGND	Power ground. PGND needs to be electrically connected to AGND.
Exposed Pad	LX	Switching node. LX is the drain of the internal power PFET. LX is used as the thermal pad of the power stage.

## Block Diagram

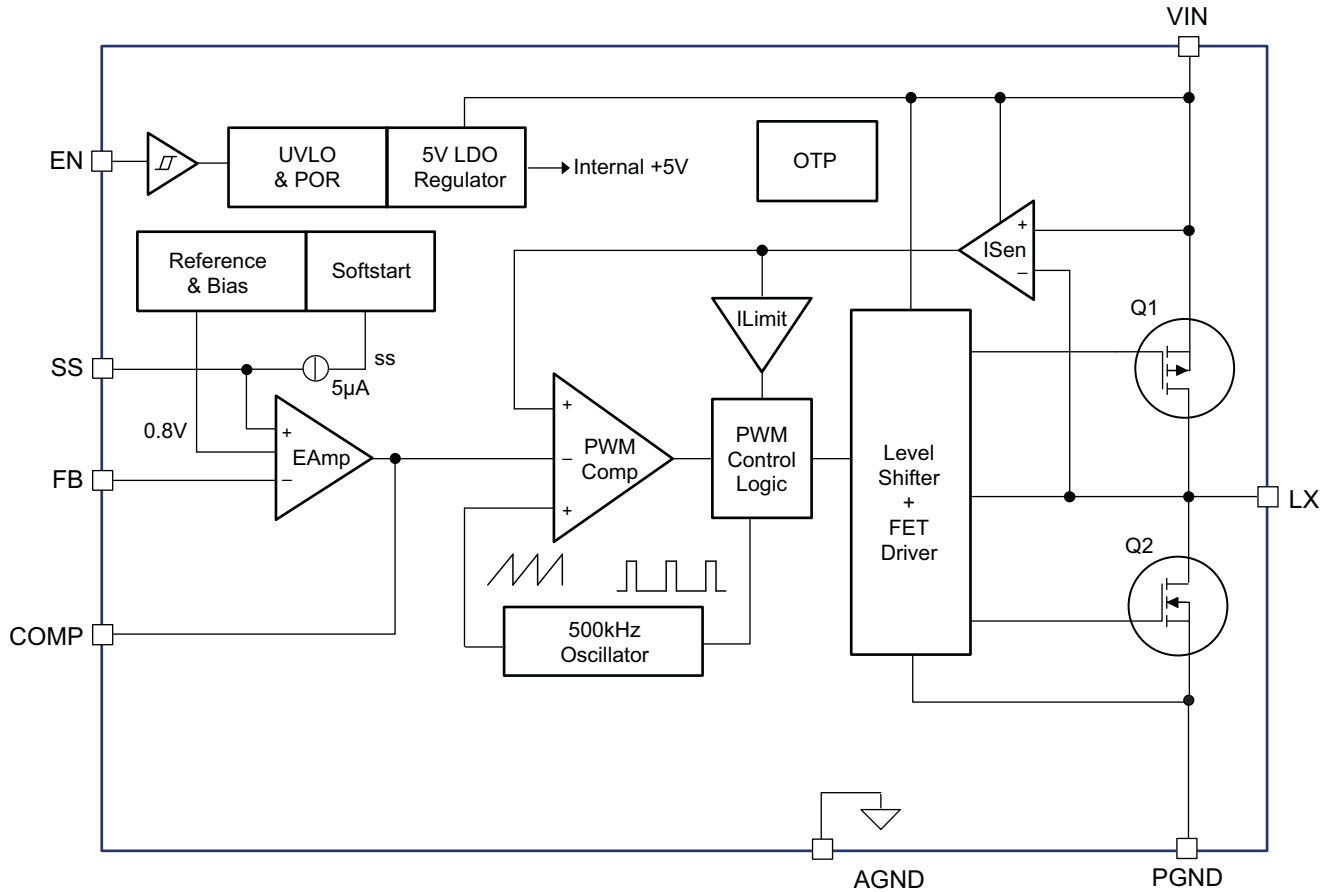

### Absolute Maximum Ratings

Exceeding the Absolute Maximum Ratings may damage the device.

Parameter	Rating
Supply Voltage ( $V_{IN}$ )	20V
LX to AGND	-0.7V to $V_{IN}+0.3V$
LX to AGND (20ns)	-5V to 22V
EN to AGND	-0.3V to $V_{IN}+0.3V$
FB, SS, COMP to AGND	-0.3V to 6.0V
PGND to AGND	-0.3V to +0.3V
Junction Temperature ( $T_J$ )	+150°C
Storage Temperature ( $T_S$ )	-65°C to +150°C
ESD Rating <sup>(1)</sup>	2.0kV

**Note:**

1. Devices are inherently ESD sensitive, handling precautions are required. Human body model rating: 1.5 k $\Omega$  in series with 100 pF.

### Recommended Operating Conditions

The device is not guaranteed to operate beyond the Maximum Recommended Operating Conditions.

Parameter	Rating
Supply Voltage ( $V_{IN}$ )	4.5V to 18V
Output Voltage Range	0.8V to $0.85 \cdot V_{IN}$
Ambient Temperature ( $T_A$ )	-40°C to +85°C
Package Thermal Resistance DFN5x6 ( $\theta_{JA}$ )	40°C/W

## Electrical Characteristics

$T_A = 25^\circ\text{C}$ ,  $V_{IN} = V_{EN} = 12\text{V}$ ,  $V_{OUT} = 3.3\text{V}$  unless otherwise specified<sup>(2)</sup>

Symbol	Parameter	Conditions	Min.	Typ.	Max.	Units
$V_{IN}$	Supply Voltage		<b>4.5</b>		<b>18</b>	V
$V_{UVLO}$	Input Under-Voltage Lockout Threshold	$V_{IN}$ Rising $V_{IN}$ Falling		4.1 3.7		V
$I_{IN}$	Supply Current (Quiescent)	$I_{OUT} = 0\text{A}$ , $V_{FB} = 1.2\text{V}$ , $V_{EN} > 2\text{V}$		1.6	2.5	mA
$I_{OFF}$	Shutdown Supply Current	$V_{EN} = 0\text{V}$		<b>1</b>	<b>10</b>	$\mu\text{A}$
$V_{FB}$	Feedback Voltage	$T_A = 25^\circ\text{C}$	0.788	0.8	0.812	V
	Load Regulation			0.5		%
	Line Regulation			1		%
$I_{FB}$	Feedback Voltage Input Current				200	nA
$V_{EN}$	EN Input Threshold	Off Threshold On Threshold	<b>2</b>		<b>0.6</b>	V
$V_{HYS}$	EN Input Hysteresis			<b>100</b>		mV
	EN Leakage Current				<b>1</b>	$\mu\text{A}$
	SS Time	$C_{SS} = 16\text{nF}$		2		ms
<b>MODULATOR</b>						
$f_O$	Frequency		400	500	600	kHz
$D_{MAX}$	Maximum Duty Cycle		85			%
$T_{MIN}$	Controllable Minimum On-Time				150	ns
	Current Sense Transconductance			8		A/V
	Error Amplifier Transconductance			200		$\mu\text{A}/\text{V}$
<b>PROTECTION</b>						
$I_{LIM}$	Current Limit		6.8	7.5		A
	Over-Temperature Shutdown Limit	$T_J$ Rising $T_J$ Falling		150 100		$^\circ\text{C}$
<b>OUTPUT STAGE</b>						
	High-Side Switch On-Resistance	$V_{IN} = 12\text{V}$		30		m $\Omega$
		$V_{IN} = 5\text{V}$		52		
	Low-Side Switch On-Resistance	$V_{IN} = 12\text{V}$		15		m $\Omega$
		$V_{IN} = 5\text{V}$		19		

**Note:**

2. Specification in **BOLD** indicate an ambient temperature range of  $-40^\circ\text{C}$  to  $+85^\circ\text{C}$ . These specifications are not guaranteed to operate beyond the Maximum Operating ratings.

### Typical Performance Characteristics

Circuit of Figure 1.  $T_A = 25^\circ\text{C}$ ,  $V_{IN} = V_{EN} = 12\text{V}$ ,  $V_{OUT} = 3.3\text{V}$  unless otherwise specified.

Light Load Operation

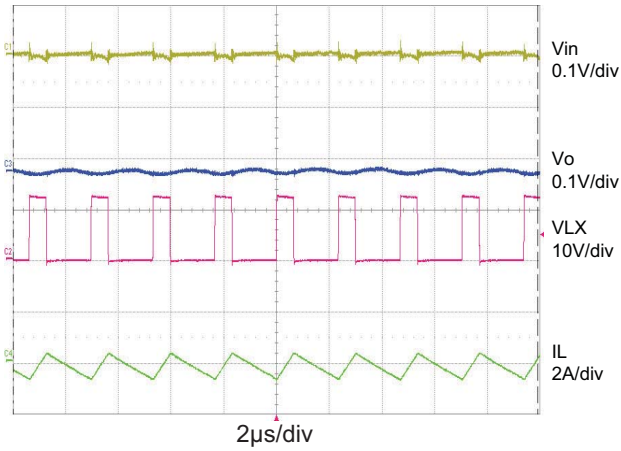

Full Load Operation

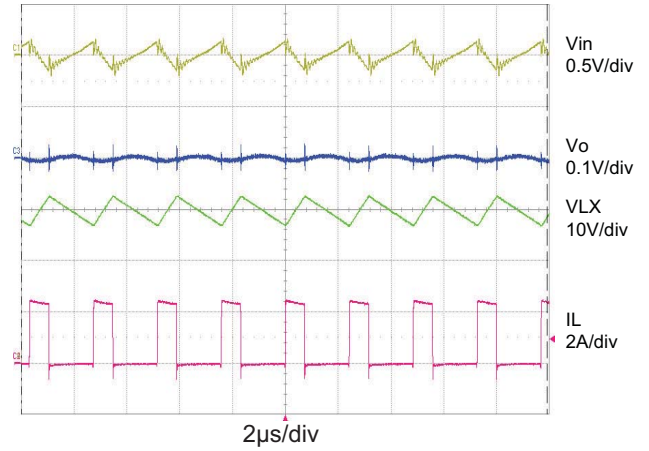

Short Circuit Protection

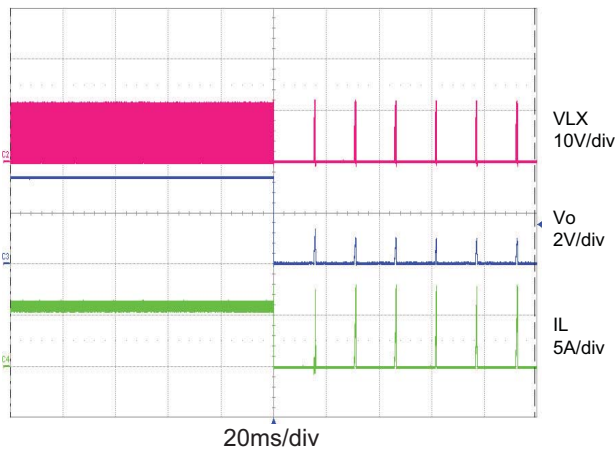

Short Circuit Recovery

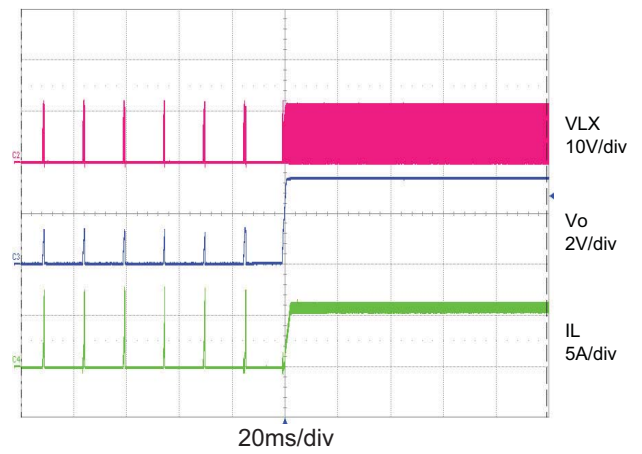

Start Up to Full Load

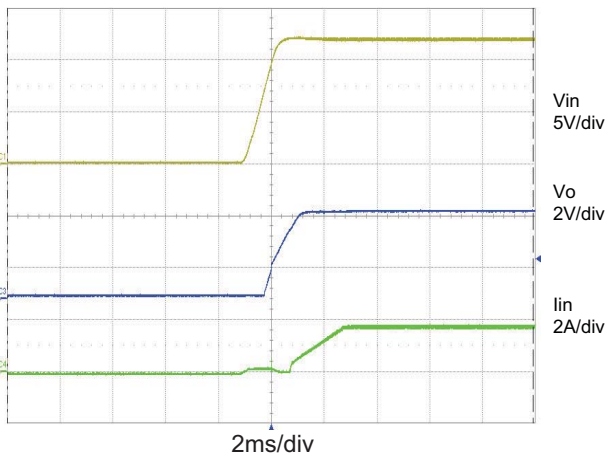

50 % to 100 % Load Transient

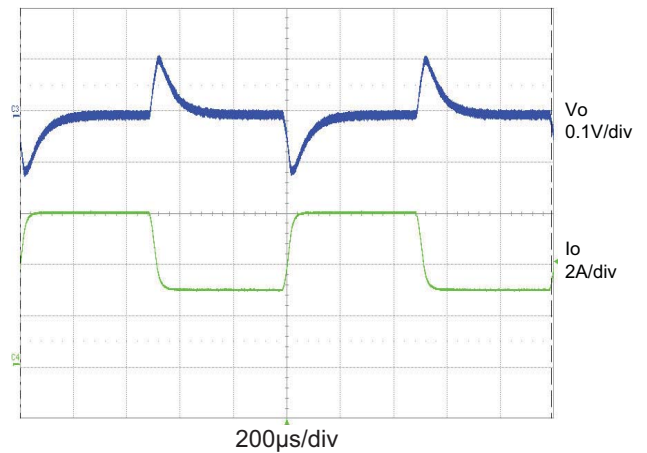

## Efficiency

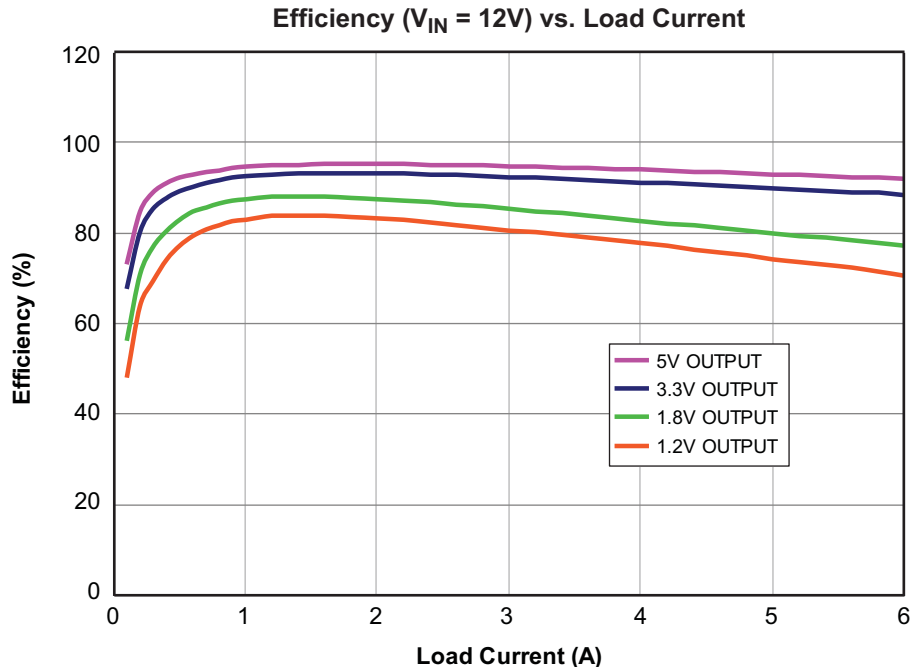

### Detailed Description

The AOZ3019 is a current-mode step down regulator with an integrated high-side PMOS switch and a low-side NMOS switch. The AOZ3019 operates from a 4.5V to 18V input voltage range and supplies up to 6A of load current. Features include enable control, power-on reset, input under voltage lockout, output over voltage protection, external soft-start and thermal shut down.

The AOZ3019 is available in a DFN5x6 package.

#### Enable and Soft Start

The AOZ3019 has an external soft start feature to limit in-rush current and ensure the output voltage ramps up smoothly to regulation voltage. The soft start process begins when the input voltage rises to 4.1V and voltage on the EN pin is HIGH. In the soft start process, the FB voltage is ramped to follow the voltage of soft start pin until it reaches 0.8V. The voltage of the soft start pin is charged internally by a 5 $\mu$ A current source.

The EN pin of the AOZ3019 is active high. Connect the EN pin to VIN if the enable function is not used. Pulling EN to ground will disable the AOZ3019. Do not leave EN open. The voltage on the EN pin must be above 2V to enable the AOZ3019. When the EN pin voltage falls below 0.6V, the AOZ3019 is disabled.

#### Steady-State Operation

Under heavy load steady-state conditions, the converter operates in fixed frequency and Continuous-Conduction Mode (CCM).

The AOZ3019 integrates an internal P-MOSFET as the high-side switch. Inductor current is sensed by amplifying the voltage drop across the drain to source of the high side power MOSFET. Output voltage is divided down by the external voltage divider at the FB pin. The difference of the FB pin voltage and reference voltage is amplified by the internal transconductance error amplifier. The error voltage, which shows on the COMP pin, is compared against the current signal, which is the sum of inductor current signal and ramp compensation signal, at the PWM comparator input. If the current signal is less than the error voltage, the internal high-side switch is on. The inductor current flows from the input through the inductor to the output. When the current signal exceeds the error voltage, the high-side switch is off. The inductor current is freewheeling through the internal low-side N-MOSFET switch to output. The internal adaptive FET driver guarantees no turn on overlap of both the high-side and the low-side switch.

Compared with regulators using freewheeling Schottky diodes, the AOZ3019 uses a freewheeling NMOSFET to realize synchronous rectification. This greatly improves the converter efficiency and reduces power loss in the low-side switch.

The AOZ3019 uses a P-Channel MOSFET as the high-side switch. This saves the bootstrap capacitor normally seen in a circuit using an NMOS switch.

### Output Voltage Programming

Output voltage can be set by feeding back the output to the FB pin using a resistor divider network as shown in Figure 1. The resistor divider network includes  $R_1$  and  $R_2$ . Usually, a design is started by picking a fixed  $R_2$  value and calculating the required  $R_1$  with the equation below:

$$V_O = 0.8 \times \left( 1 + \frac{R_1}{R_2} \right)$$

Some standard value of  $R_1$  and  $R_2$  for the most common output voltages are listed in Table 1.

Table 1.

$V_O$ (V)	$R_1$ (k $\Omega$ )	$R_2$ (k $\Omega$ )
0.8	1.0	Open
1.2	4.99	10
1.5	10	11.5
1.8	12.7	10.2
2.5	21.5	10
3.3	31.1	10
5.0	52.3	10

The combination of  $R_1$  and  $R_2$  should be large enough to avoid drawing excessive current from the output, which will cause power loss.

## Protection Features

The AOZ3019 has multiple protection features to prevent system circuit damage under abnormal conditions.

### Over Current Protection (OCP)

The sensed inductor current signal is also used for over current protection. Since the AOZ3019 employs peak current mode control, the COMP pin voltage is proportional to the peak inductor current. The COMP pin voltage is limited to be between 0.4V and 2.5V internally. The peak inductor current is automatically limited cycle-by-cycle.

When the output is shorted to ground under fault conditions, the inductor current slowly decays during a switching cycle because the output voltage is 0V. To prevent catastrophic failure, a secondary current limit is designed inside the AOZ3019. The measured inductor current is compared against a preset voltage which represents the current limit. When the output current is greater than the current limit, the high side switch will be turned off. The converter will initiate a soft start once the over-current condition is resolved.

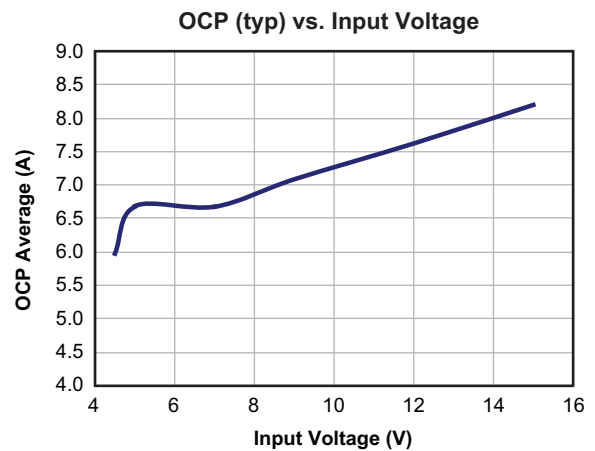

### Power-On Reset (POR)

A power-on reset circuit monitors the input voltage. When the input voltage exceeds 4.1V, the converter starts operation. When input voltage falls below 3.7V, the converter will be shut down.

### Thermal Protection

An internal temperature sensor monitors the junction temperature. The sensor shuts down the internal control circuit and high side PMOS if the junction temperature exceeds 150°C. The regulator will restart automatically under the control of the soft-start circuit when the junction temperature decreases to 100°C.

## Application Information

The basic AOZ3019 application circuit is shown in Figure 1. Component selection is explained below.

### Input Capacitor

The input capacitor must be connected to the VIN pin and the PGND pin of AOZ3019 to maintain steady input voltage and filter out the pulsing input current. The voltage rating of input capacitor must be greater than maximum input voltage plus ripple voltage.

The input ripple voltage can be approximated by equation below:

$$\Delta V_{IN} = \frac{I_O}{f \times C_{IN}} \times \left(1 - \frac{V_O}{V_{IN}}\right) \times \frac{V_O}{V_{IN}}$$

Since the input current is discontinuous in a buck converter, the current stress on the input capacitor is another concern when selecting the capacitor. For a buck circuit, the RMS value of input capacitor current can be calculated by:

$$I_{CIN\_RMS} = I_O \times \sqrt{\frac{V_O}{V_{IN}} \left(1 - \frac{V_O}{V_{IN}}\right)}$$

if we let  $m$  equal the conversion ratio:

$$\frac{V_O}{V_{IN}} = m$$

The relationship between the input capacitor RMS current and voltage conversion ratio is calculated and shown in Figure 2 below. It can be seen that when  $V_O$  is half of  $V_{IN}$ ,  $C_{IN}$  is under the worst current stress. The worst current stress on  $C_{IN}$  is  $0.5 \times I_O$ .

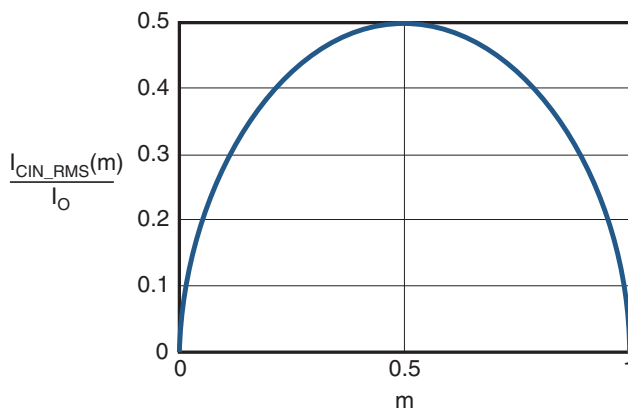

Figure 2.  $I_{CIN}$  vs. Voltage Conversion Ratio

For reliable operation and best performance, the input capacitors must have a current rating higher than  $I_{CIN\_RMS}$  at the worst operating conditions. Ceramic capacitors are preferred for input capacitors because of their low ESR and high current rating. Depending on the application circuits, other low ESR tantalum capacitors may be used. When selecting ceramic capacitors, X5R or X7R type dielectric ceramic capacitors should be used for their better temperature and voltage characteristics. Note that the ripple current rating from capacitor manufacturers are based on a certain operating life time. Further de-rating may need to be considered for long term reliability.

### Inductor

The inductor is used to supply constant current to output when it is driven by a switching voltage. For a given input and output voltage, inductance and switching frequency together decide the inductor ripple current, which is:

$$\Delta I_L = \frac{V_O}{f \times L} \times \left(1 - \frac{V_O}{V_{IN}}\right)$$

The peak inductor current is:

$$I_{Lpeak} = I_O + \frac{\Delta I_L}{2}$$

High inductance gives low inductor ripple current but requires larger size inductor to avoid saturation. Low ripple current reduces inductor core losses. It also reduces RMS current through inductor and switches, which results in less conduction loss. Usually, peak to peak ripple current on the inductor is designed to be 20% to 40% of output current.

When selecting the inductor, confirm it is able to handle the peak current without saturation at the highest operating temperature.

The inductor takes the highest current in a buck circuit. The conduction loss on the inductor needs to be checked for thermal and efficiency requirements.

Surface mount inductors in different shape and styles are available from Coilcraft, Elytone and Murata. Shielded inductors are small and radiate less EMI noise. However, they cost more than unshielded inductors. The choice depends on EMI requirement, price and size.



## Output Capacitor

The output capacitor is selected based on the DC output voltage rating, output ripple voltage specification and ripple current rating.

The selected output capacitor must have a higher rated voltage specification than the maximum desired output voltage including ripple. De-rating needs to be considered for long term reliability.

Output ripple voltage specification is another important factor for selecting the output capacitor. In a buck converter circuit, output ripple voltage is determined by inductor value, switching frequency, output capacitor value and ESR. It can be calculated by the equation below:

$$\Delta V_O = \Delta I_L \times \left( ESR_{CO} + \frac{1}{8 \times f \times C_O} \right)$$

where,

$C_O$  is output capacitor value, and

$ESR_{CO}$  is the equivalent series resistance of the output capacitor.

When a low ESR ceramic capacitor is used as the output capacitor, the impedance of the capacitor at the switching frequency dominates. Output ripple is mainly caused by capacitor value and inductor ripple current. The output ripple voltage calculation can be simplified to:

$$\Delta V_O = \Delta I_L \times \frac{1}{8 \times f \times C_O}$$

If the impedance of ESR at switching frequency dominates, the output ripple voltage is mainly decided by capacitor ESR and inductor ripple current. The output ripple voltage calculation can be further simplified to:

$$\Delta V_O = \Delta I_L \times ESR_{CO}$$

For lower output ripple voltage across the entire operating temperature range, X5R or X7R dielectric type of ceramic, or other low ESR tantalum capacitors are recommended as output capacitors.

In a buck converter, output capacitor current is continuous. The RMS current of output capacitor is decided by the peak to peak inductor ripple current. It can be calculated by:

$$I_{CO\_RMS} = \frac{\Delta I_L}{\sqrt{12}}$$

Usually, the ripple current rating of the output capacitor is a smaller issue because of the low current stress. When the buck inductor is selected to be very small and inductor ripple current is high, the output capacitor could be overstressed.

## Loop Compensation

The AOZ3019 employs peak current mode control for ease of use and fast transient response. Peak current mode control eliminates the double pole effect of the output L&C filter. It also greatly simplifies the compensation loop design.

With peak current mode control, the buck power stage can be simplified to be a one-pole and one-zero system in frequency domain. The pole is dominant pole can be calculated by:

$$f_{P1} = \frac{1}{2\pi \times C_O \times R_L}$$

The zero is a ESR zero due to the output capacitor and its ESR. It can be calculated by:

$$f_{Z1} = \frac{1}{2\pi \times C_O \times ESR_{CO}}$$

where;

$C_O$  is the output filter capacitor,

$R_L$  is load resistor value, and

$ESR_{CO}$  is the equivalent series resistance of output capacitor.

The compensation design shapes the converter control loop transfer function for the desired gain and phase. Several different types of compensation networks can be used with the AOZ3019. For most cases, a series capacitor and resistor network connected to the COMP pin sets the pole-zero and is adequate for a stable high-bandwidth control loop.

In the AOZ3019, FB and COMP are the inverting input and the output of the internal error amplifier. A series R and C compensation network connected to COMP provides one pole and one zero. The pole is:

$$f_{P2} = \frac{G_{EA}}{2\pi \times C_C \times G_{VEA}}$$

where;

$G_{EA}$  is the error amplifier transconductance, which is  $200 \times 10^{-6}$  A/V,

$G_{VEA}$  is the error amplifier voltage gain, which is 500 V/V, and

$C_C$  is the compensation capacitor in Figure 1.

The zero given by the external compensation network, capacitor  $C_C$  and resistor  $R_C$ , is located at:

$$f_{Z2} = \frac{1}{2\pi \times C_C \times R_C}$$

To design the compensation circuit, a target crossover frequency  $f_C$  to close the loop must be selected. The system crossover frequency is where the control loop has unity gain. The crossover is also called the converter bandwidth. Generally a higher bandwidth means faster response to load transients. However, the bandwidth should not be too high because of system stability concern. When designing the compensation loop, converter stability under all line and load condition must be considered.

Usually, it is recommended to set the bandwidth to be equal or less than 1/10 of the switching frequency.

The strategy for choosing  $R_C$  and  $C_C$  is to set the crossover frequency with  $R_C$  and set the compensator zero with  $C_C$ . Using selected crossover frequency,  $f_C$ , to calculate  $R_C$ :

$$R_C = f_C \times \frac{V_O}{V_{FB}} \times \frac{2\pi \times C_C}{G_{EA} \times G_{CS}}$$

where;

$f_C$  is the desired crossover frequency. For best performance,  $f_C$  is set to be about 1/10 of the switching frequency;

$V_{FB}$  is 0.8V,

$G_{EA}$  is the error amplifier transconductance, which is  $200 \times 10^{-6} \text{A/V}$ , and

$G_{CS}$  is the current sense circuit transconductance, which is  $8 \text{A/V}$

The compensation capacitor  $C_C$  and resistor  $R_C$  together make a zero. This zero is put somewhere close to the dominate pole  $f_{p1}$  but lower than 1/5 of the selected crossover frequency.  $C_C$  can be selected by:

$$C_C = \frac{1.5}{2\pi \times R_C \times f_{P1}}$$

The above equation can be simplified to:

$$C_C = \frac{C_O \times R_L}{R_C}$$

An easy-to-use application software which helps to design and simulate the compensation loop can be found at [www.aosmd.com](http://www.aosmd.com).

## Thermal Management and Layout Considerations

In the AOZ3019 buck regulator circuit, high pulsing current flows through two circuit loops. The first loop starts from the input capacitors, to the VIN pin, to the LX pins, to the filter inductor, to the output capacitor and load, and then return to the input capacitor through ground. Current flows in the first loop when the high side switch is on. The second loop starts from inductor, to the output capacitors and load, to the low-side NMOSFET. Current flows in the second loop when the low-side NMOSFET is on.

In PCB layout, minimizing the two loops area reduces the noise of this circuit and improves efficiency. A ground plane is strongly recommended to connect input capacitor, output capacitor, and PGND pin of the AOZ3019.

In the AOZ3019 buck regulator circuit, the major power dissipating components are the AOZ3019 and the output inductor. The total power dissipation of converter circuit can be measured by input power minus output power.

$$P_{total\_loss} = V_{IN} \times I_{IN} - V_O \times I_O$$

The power dissipation of inductor can be approximately calculated by output current and DCR of inductor.

$$P_{inductor\_loss} = I_O^2 \times R_{inductor} \times 1.1$$

The actual junction temperature can be calculated with power dissipation in the AOZ3019 and thermal impedance from junction to ambient.

$$T_{junction} = (P_{total\_loss} - P_{inductor\_loss}) \times \Theta_{JA}$$

The maximum junction temperature of AOZ3019 is  $150^\circ\text{C}$ , which limits the maximum load current capability. Please see the thermal de-rating curves for maximum load current of the AOZ3019 under different ambient temperatures.

The thermal performance of the AOZ3019 is strongly affected by the PCB layout. Extra care should be taken by users during design process to ensure that the IC will operate under the recommended environmental conditions.

## Layout Considerations

The AOZ3019 is a DFN5x6 package. Layout tips are listed below for the best electric and thermal performance.

1. The exposed pad (LX) is connected to internal PFET and NFET drains. Connect a large copper plane to the LX pin to help thermal dissipation.
2. Do not use thermal relief connection to the VIN and the PGND pin. Pour a maximized copper area to the PGND pin and the VIN pin to help thermal dissipation.
3. Input capacitor should be connected as close as possible to the VIN pin and the PGND pin.
4. A ground plane is suggested. If a ground plane is not used, separate PGND from AGND and connect them only at one point to avoid the PGND pin noise coupling to the AGND pin.
5. Make the current trace from the LX pins to L to  $C_O$  to the PGND as short as possible.
6. Pour copper plane on all unused board area and connect it to stable DC nodes, like  $V_{IN}$ , GND or  $V_{OUT}$ .
7. Keep sensitive signal traces far away from the LX pins.

Package Dimensions, DFN5x6, 8L, EP1\_P

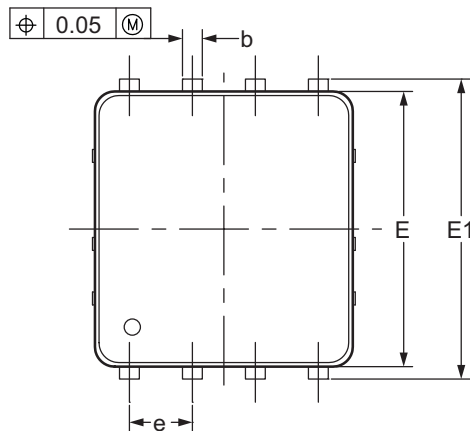

TOP VIEW

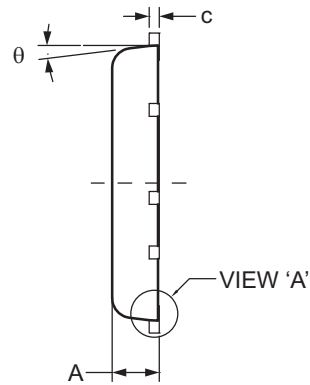

SIDE VIEW

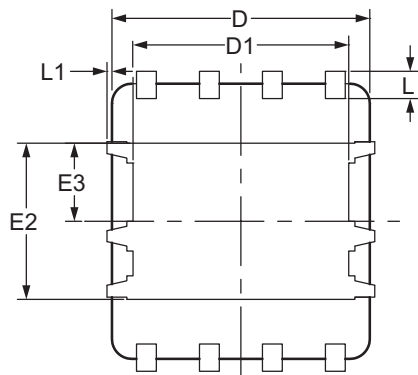

BOTTOM VIEW

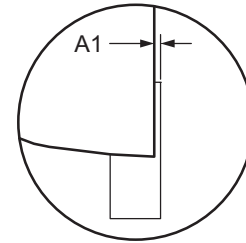

VIEW 'A'  
(SCALE 5:1)

RECOMMENDED LAND PATTERN

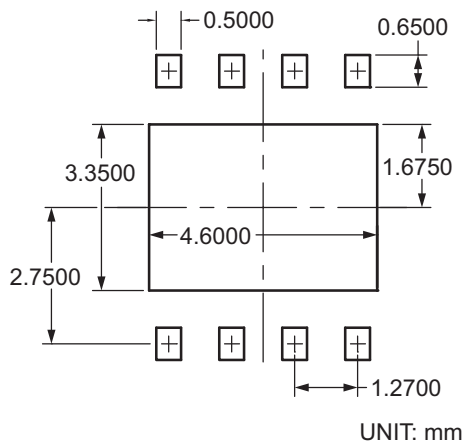

Dimensions in millimeters

Symbols	Min.	Nom.	Max.
A	0.85	0.95	1.00
A1	0.00	—	0.05
b	0.30	0.40	0.50
c	0.15	0.20	0.25
D	5.20 BSC		
D1	4.35 BSC		
E	5.55 BSC		
E1	6.05 BSC		
E2	3.15 BSC		
E3	1.575 BSC		
e	1.27 BSC		
L	0.45	0.55	0.65
L1	0	—	0.15
θ	0°	—	10°

Dimensions in inches

Symbols	Min.	Nom.	Max.
A	0.033	0.037	0.039
A1	0.000	—	0.002
b	0.012	0.016	0.020
c	0.006	0.008	0.010
D	0.205 BSC		
D1	0.171 BSC		
E	0.219 BSC		
E1	0.238 BSC		
E2	0.124 BSC		
E3	0.062 BSC		
e	0.050 BSC		
L	0.018	0.022	0.026
L1	0	—	0.006
θ	0°	—	10°

Notes:

1. Package body sizes exclude mold flash and gate burrs. Mold flash at the non-lead sides should be less than 6 mils each.
2. Controlling dimension is millimeter. Converted inch dimensions are not necessarily exact.

### Tape and Reel Dimensions, DFN5x6, 8L, EP1\_P

#### Carrier Tape

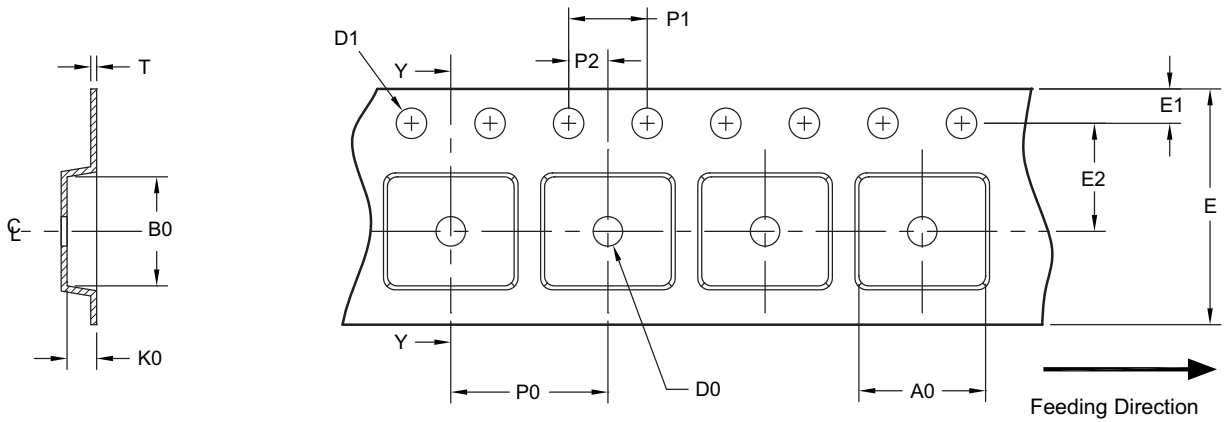

UNIT: MM

Package	A0	B0	K0	D0	D1	E	E1	E2	P0	P1	P2	T
DFN 5x6 (12mm)	6.30 $\pm 0.10$	5.45 $\pm 0.10$	1.30 $\pm 0.10$	1.50 Min.	1.55 $\pm 0.05$	12.00 $\pm 0.30$	1.75 $\pm 0.10$	5.50 $\pm 0.10$	8.00 $\pm 0.10$	4.00 $\pm 0.10$	2.00 $\pm 0.10$	0.30 $\pm 0.05$

#### Reel

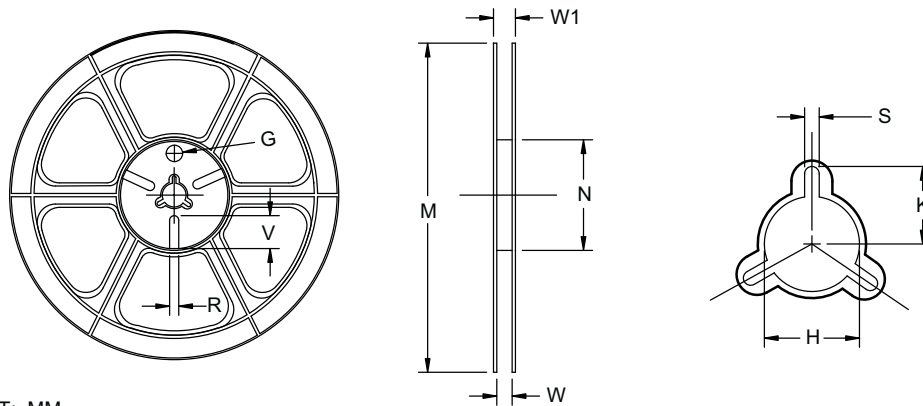

UNIT: MM

Tape Size	Reel Size	M	N	W	W1	H	K	S	G	R	V
12 mm	$\varnothing 330$	$\varnothing 330.0$ $\pm 0.50$	$\varnothing 97.00$ $\pm 0.10$	13.00 $\pm 0.30$	17.40 $\pm 1.00$	$\varnothing 13.0$ $+0.50/-0.20$	10.60	2.0 $\pm 0.5$	—	—	—

#### Leader/Trailer and Orientation

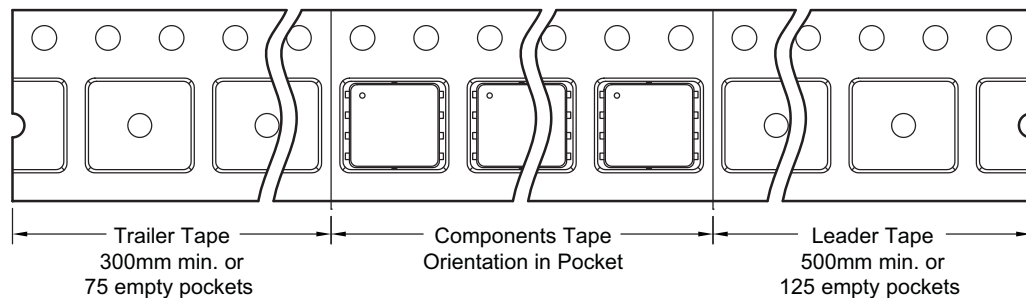

**Part Marking**

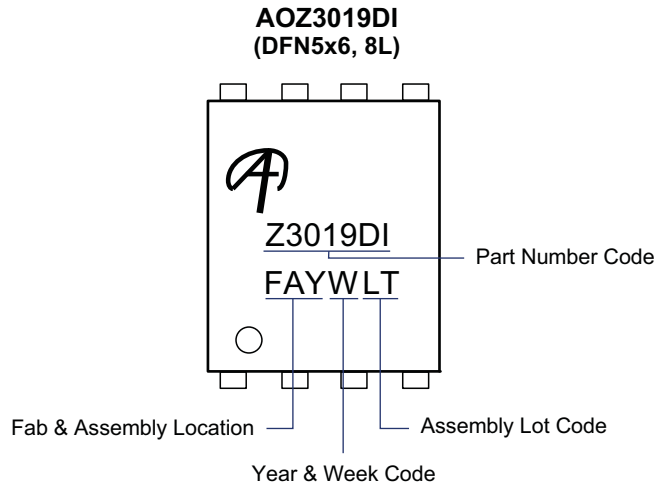

**LEGAL DISCLAIMER**

Alpha and Omega Semiconductor makes no representations or warranties with respect to the accuracy or completeness of the information provided herein and takes no liabilities for the consequences of use of such information or any product described herein. Alpha and Omega Semiconductor reserves the right to make changes to such information at any time without further notice. This document does not constitute the grant of any intellectual property rights or representation of non-infringement of any third party’s intellectual property rights.

**LIFE SUPPORT POLICY**

ALPHA AND OMEGA SEMICONDUCTOR PRODUCTS ARE NOT AUTHORIZED FOR USE AS CRITICAL COMPONENTS IN LIFE SUPPORT DEVICES OR SYSTEMS.

As used herein:

1. Life support devices or systems are devices or systems which, (a) are intended for surgical implant into the body or (b) support or sustain life, and (c) whose failure to perform when properly used in accordance with instructions for use provided in the labeling, can be reasonably expected to result in a significant injury of the user.
2. A critical component in any component of a life support, device, or system whose failure to perform can be reasonably expected to cause the failure of the life support device or system, or to affect its safety or effectiveness.

单击下面可查看定价，库存，交付和生命周期等信息

[>>AOS\(万代\)](#)