

General Description

The AOZ8131-06 is an ultra low capacitance one-line bi-directional transient voltage suppressor diode designed to protect high speed data lines and voltage sensitive electronics from high transient conditions and ESD.

This device incorporates one TVS diode in an ultra-small DFN 1006 package. It may be used to meet the ESD immunity requirements of IEC 61000-4-2, Level 4 ($\pm 15\text{kV}$ air, $\pm 8\text{kV}$ contact discharge).

The AOZ8131-06 comes in an RoHS compliant DFN 1006 package and is rated over a -40°C to $+85^{\circ}\text{C}$ ambient temperature range.

The ultra-small $1.0 \times 0.6 \times 0.5\text{mm}$ DFN package makes it ideal for applications where PCB space is a premium. The small size and high ESD protection makes it ideal for protecting voltage sensitive electronics from high transient conditions and ESD.

Features

- ESD protection for high-speed data lines:
 - Exceeds:
 - IEC 61000-4-2 (ESD) $\pm 24\text{kV}$ (air), $\pm 24\text{kV}$ (contact)
 - IEC 61000-4-4 (EFT) $\pm 40\text{A}$ (5/50ns)
 - IEC 61000-4-5 (Lightning) $\pm 4\text{A}$
 - Human Body Model (HBM) $\pm 30\text{kV}$
- Small package saves board space
- Ultra low capacitance: 1.25pF
- Low clamping voltage
- Low operating voltage: 6.0V
- Pb-free device

Applications

- Portable handheld devices
- Keypads, data lines, buttons
- Notebook computers
- Digital cameras
- Portable GPS
- MP3 players



Typical Application

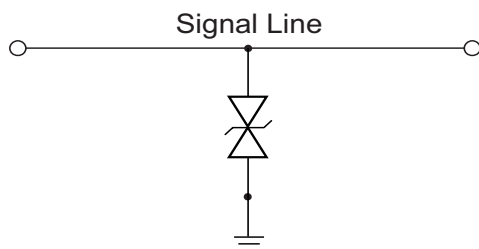

Bidirection Protection of Single Line

Pin Configuration



Ordering Information

Part Number	Ambient Temperature Range	Package	Environmental
AOZ8131DI-06	-40°C to +85°C	DFN 1006	RoHS Compliant Green Product



AOS Green Products use reduced levels of Halogens, and are also RoHS compliant.

Please visit www.aosmd.com/media/AOSGreenPolicy.pdf for additional information.

Absolute Maximum Ratings

Exceeding the Absolute Maximum ratings may damage the device.

Parameter	Rating
Peak Pulse Current (I_{PP}), $t_P = 8/20\mu s$	4A
Storage Temperature (T_S)	-65°C to +150°C
ESD Rating per IEC61000-4-2, Contact ⁽¹⁾	±24kV
ESD Rating per IEC61000-4-2, Air ⁽¹⁾	±24kV
ESD Rating per Human Body Model ⁽²⁾	±30kV

Notes:

- IEC 61000-4-2 discharge with $C_{Discharge} = 150pF$, $R_{Discharge} = 330\Omega$.
- Human Body Discharge per MIL-STD-883, Method 3015 $C_{Discharge} = 100pF$, $R_{Discharge} = 1.5k\Omega$.

Maximum Operating Ratings

Parameter	Rating
Junction Temperature (T_J)	-40°C to +125°C

Electrical Characteristics

T_A = 25°C unless otherwise specified.

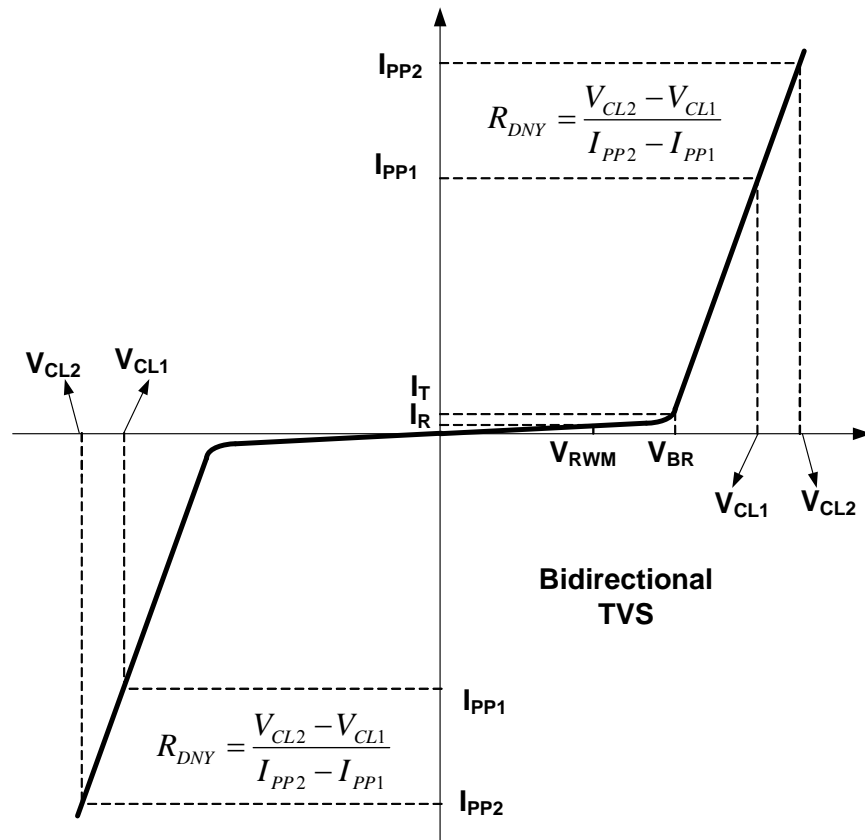

Symbol	Parameter	Conditions	Min.	Typ.	Max.	Units
V _{RWM}	Reverse Working Voltage	Pin1 to Pin2 or Pin2 to Pin1			6	V
V _{BR}	Reverse Breakdown Voltage	I _T =1mA	7		9.5	V
I _R	Reverse Leakage Current	V _{RWM} =6V			100	nA
V _{CL}	Clamping Voltage ⁽³⁾ (Transmission Line Pulse, Tp=100ns, Tr=1ns))	I _{TLP} =1A		12		V
		I _{TLP} =16A		25		
R _{DNY}	Dynamic Resistance ⁽³⁾	I _{TLP} = 1A to 16A		0.85		Ω
C _J	Junction Capacitance	V _{I/O} =0V, f=1MHz		1.2	2.0	pF

Note:

3. These specifications are guaranteed by design and characterization.

Typical Performance Characteristics

Positive TLP Clamping
($t_p = 100\text{ns}$, $t_r = 1\text{ns}$)

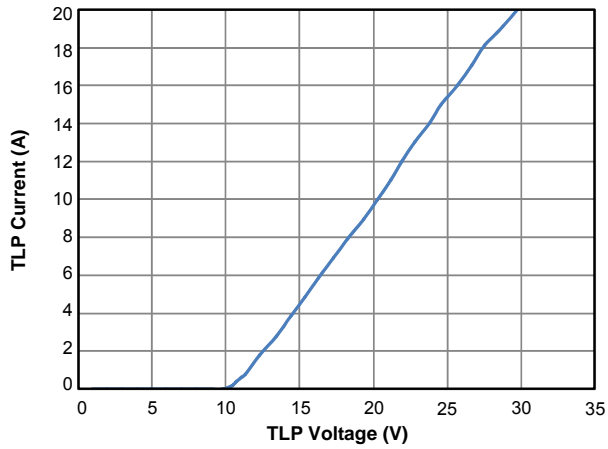

Negative TLP Clamping
($t_p = 100\text{ns}$, $t_r = 1\text{ns}$)

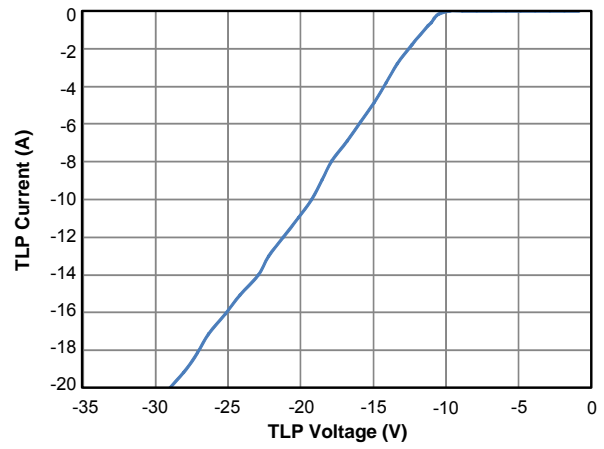

+8kV ESD Clamping Per IEC 61000-4-2
(Contact, Between IO to GND)

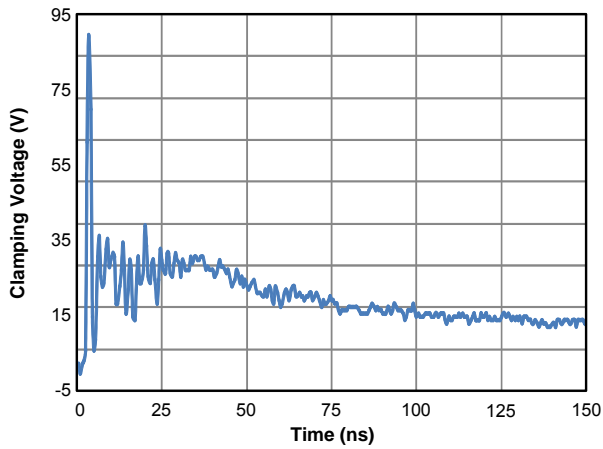

-8kV ESD Clamping Per IEC 61000-4-2
(Contact, Between IO to GND)

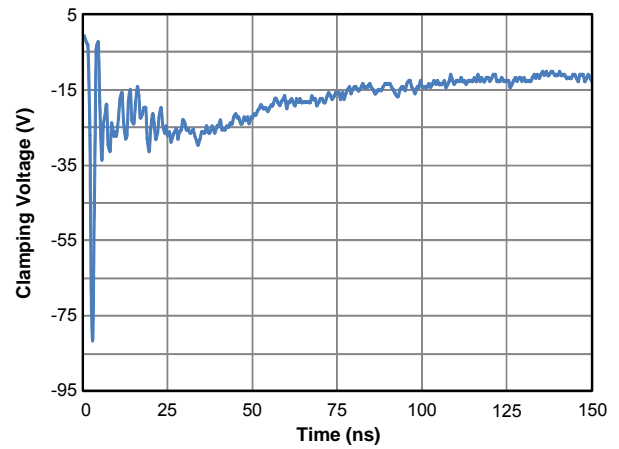

Package Dimensions, DFN 1006

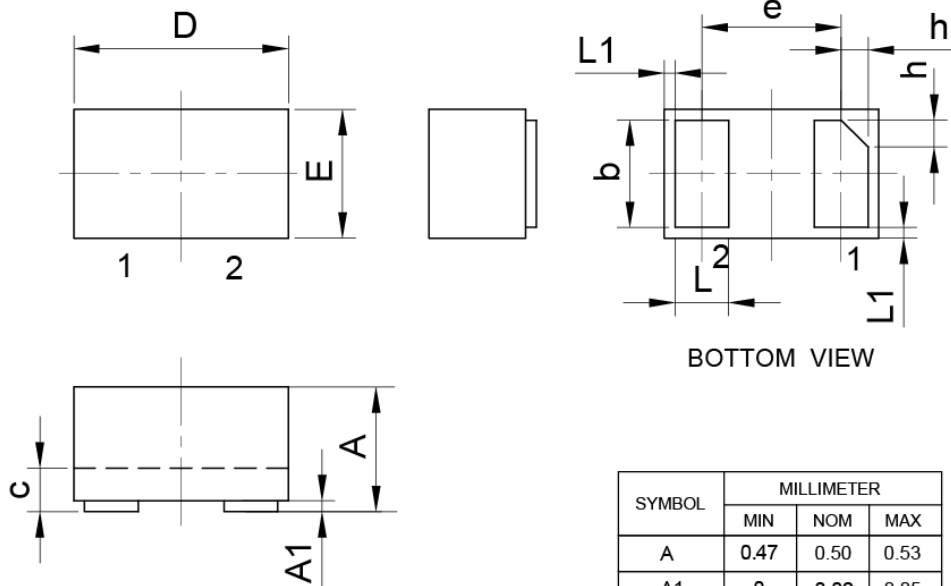

SYMBOL	MILLIMETER		
	MIN	NOM	MAX
A	0.47	0.50	0.53
A1	0	0.02	0.05
b	0.45	0.50	0.55
c	0.12	0.15	0.18
D	0.95	1.00	1.05
e	0.65BSC		
E	0.55	0.60	0.65
L	0.20	0.25	0.30
L1	0.05REF		
h	0.07	0.12	0.17

Tape and Reel Dimensions, DFN 1006

Carrier Tape

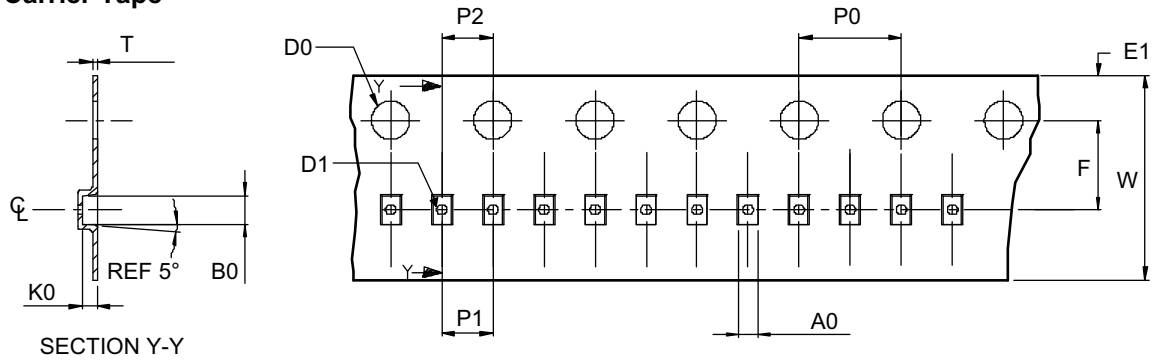

UNIT: mm

Package	A0	B0	K0	D0	D1	E1	F	P0	P1	P2	T	W
DFN 1.0x0.6 (8 mm)	0.65 ±0.04	1.05 ±0.04	0.61 ±0.04	ø1.50 +0.1/-0.0	ø0.40 ±0.05	1.75 ±0.10	3.50 ±0.05	4.00 ±0.10	2.00 ±0.10	2.00 ±0.05	0.20 ±0.05	8.00 +0.3/-0.1

Reel

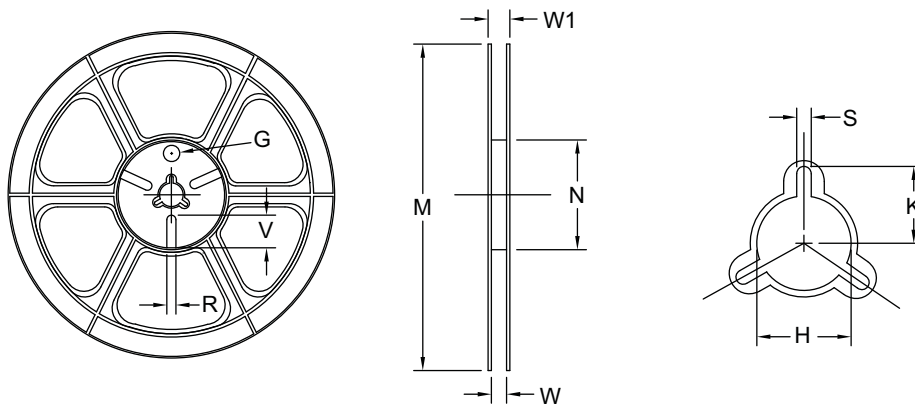

UNIT: mm

Tape Size	Reel Size	M	N	W	W1	H	K	S	G	R	V
8mm	ø178	ø178 ±0.5	ø55 ±1	8.4 +1.5/-0	14.4. Max.	ø13.0 ±0.5	10.0 ±0.5	2.0 ±0.5	N/A	N/A	N/A

Leader / Trailer & Orientation

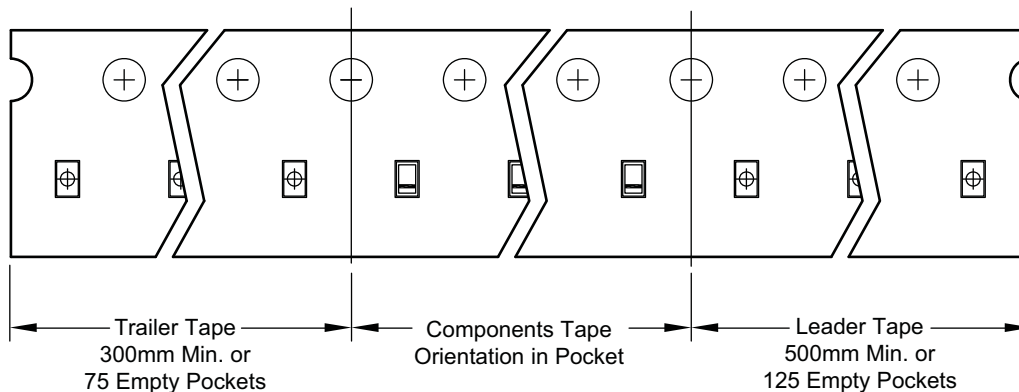

Part Marking

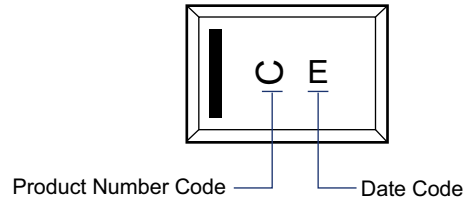

LEGAL DISCLAIMER

Alpha and Omega Semiconductor makes no representations or warranties with respect to the accuracy or completeness of the information provided herein and takes no liabilities for the consequences of use of such information or any product described herein. Alpha and Omega Semiconductor reserves the right to make changes to such information at any time without further notice. This document does not constitute the grant of any intellectual property rights or representation of non-infringement of any third party's intellectual property rights.

LIFE SUPPORT POLICY

ALPHA AND OMEGA SEMICONDUCTOR PRODUCTS ARE NOT AUTHORIZED FOR USE AS CRITICAL COMPONENTS IN LIFE SUPPORT DEVICES OR SYSTEMS.

As used herein:

1. Life support devices or systems are devices or systems which, (a) are intended for surgical implant into the body or (b) support or sustain life, and (c) whose failure to perform when properly used in accordance with instructions for use provided in the labeling, can be reasonably expected to result in a significant injury of the user.
2. A critical component in any component of a life support, device, or system whose failure to perform can be reasonably expected to cause the failure of the life support device or system, or to affect its safety or effectiveness.

单击下面可查看定价，库存，交付和生命周期等信息

[>>AOS\(万国半导体\)](#)