

## General Description

The AOZ8251BDI-03 is a one-line bi-directional transient voltage suppressor diode designed to protect voltage sensitive electronics from high transient conditions and ESD.

This device incorporates bi-directional TVS diode in an ultra-small DFN 1006 package. It may be used to meet the ESD immunity requirements of IEC 61000-4-2, Level 4 ( $\pm 15\text{kV}$  air,  $\pm 8\text{kV}$  contact discharge).

The AOZ8251BDI-03 comes in an RoHS compliant DFN 1.0 mm x 0.6 mm package and is rated over a  $-40^{\circ}\text{C}$  to  $+125^{\circ}\text{C}$  ambient temperature range.

The ultra-small 0.62 mm x 0.32 mm x 0.5 mm DFN package makes it ideal for applications where PCB space is a premium. The small size and high ESD protection makes it ideal for protecting voltage sensitive electronics from high transient conditions and ESD.

## Features

- ESD protection for high-speed data lines
  - AOZ8251BDI-03:
    - Exceeds: IEC 61000-4-2 (ESD)  $\pm 20\text{ kV}$  (air),  $\pm 20\text{ kV}$  (contact)
    - Human Body Model (HBM)  $\pm 30\text{ kV}$
    - IEC 61000-4-5 (Lightning) 4 A (8/20  $\mu\text{s}$ )
- Pb-free device

## Applications

- Portable handheld devices
- Keypads, data lines, buttons
- Notebook computers
- Digital cameras
- Portable GPS



## Typical Application

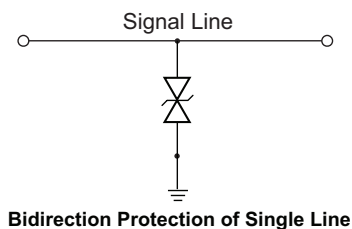

## Pin Configuration



## Ordering Information

Part Number	Ambient Temperature Range	Package	Environmental
AOZ8251BDI-03	-40°C to +125°C	DFN 0.62 x 0.32	Green Product



AOS Green Products use reduced levels of Halogens, and are also RoHS compliant. Please visit [www.aosmd.com/web/quality/rohs\\_compliant.jsp](http://www.aosmd.com/web/quality/rohs_compliant.jsp) for additional information.

## Absolute Maximum Ratings

*Exceeding the Absolute Maximum ratings may damage the device.*

Parameter	Rating
VP – VN	3.3 V
Peak Pulse Current, $t_p = 8/20 \mu s$	4 A
Storage Temperature ( $T_S$ )	-65°C to +150°C
ESD Rating per IEC61000-4-2, Contact <sup>(1)</sup>	± 20 kV
ESD Rating per IEC61000-4-2, Air <sup>(1)</sup>	± 20 kV
ESD Rating per Human Body Model <sup>(2)</sup>	± 30 kV

### Notes:

- IEC 61000-4-2 discharge with  $C_{Discharge} = 150 \text{ pF}$ ,  $R_{Discharge} = 330 \Omega$ .
- Human Body Discharge per MIL-STD-883, Method 3015  $C_{Discharge} = 100 \text{ pF}$ ,  $R_{Discharge} = 1.5 \text{ k}\Omega$ .

## Maximum Operating Ratings

Parameter	Rating
Junction Temperature ( $T_J$ )	-40°C to +125°C

## Electrical Characteristics

T<sub>A</sub> = 25°C unless otherwise specified.

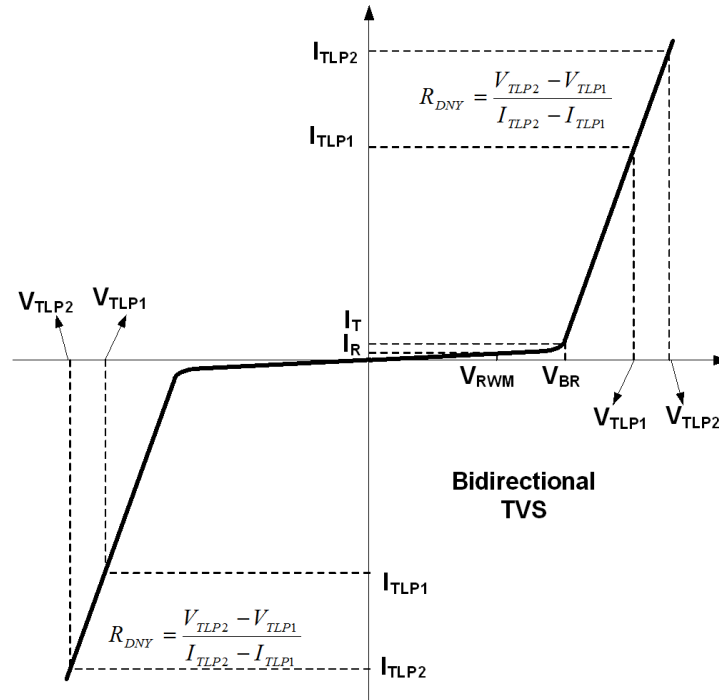

## Electrical Characteristics

Symbol	Parameter	Condition	Min.	Typ.	Max.	Units
V <sub>RWM</sub>	Reverse Working Voltage	I/O Pin-to-Ground			3.3	V
V <sub>BR</sub>	Reverse Breakdown Voltage	I <sub>T</sub> =1mA, I/O Pin-to-Ground	5.5			V
I <sub>R</sub>	Reverse Leakage Current	V <sub>RWM</sub> =3.3V, I/O Pin-to-Ground		1	100	nA
V <sub>CL</sub>	Clamping Voltage <sup>(3)</sup> (100ns Transmission Line Pulse, I/O Pin-to-Ground)	I <sub>TLP</sub> =1A		8	11	V
		I <sub>TLP</sub> =16A		17	22	V
	Clamping Voltage <sup>(3)</sup> (IEC61000-4-5, 8/20μs, I/O Pin-to-Ground)	I <sub>PP</sub> =4A		15	18	V
R <sub>DNY</sub>	Dynamic Resistance <sup>(3)</sup>	I <sub>TLP</sub> =1A to 16A		0.3		Ω
C <sub>J</sub>	Junction Capacitance	V <sub>I/O</sub> =0V, f=1MHz, I/O Pin-to-Ground		6	7.5	pF

**Note:**

3. These specifications are guaranteed by design and characterization.

## Typical Performance Characteristics

$T_A = 25^\circ\text{C}$ , unless otherwise specified.

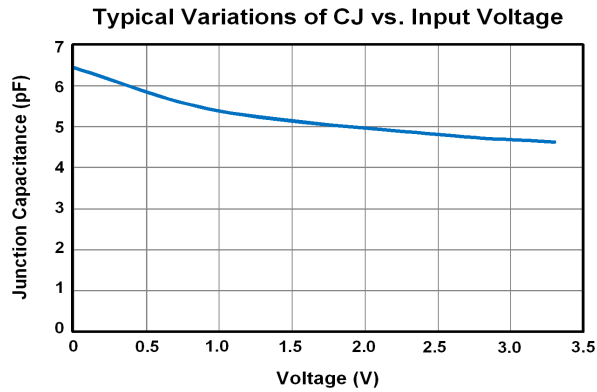
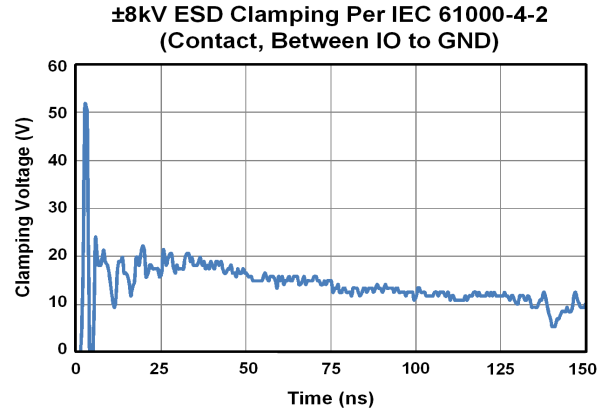
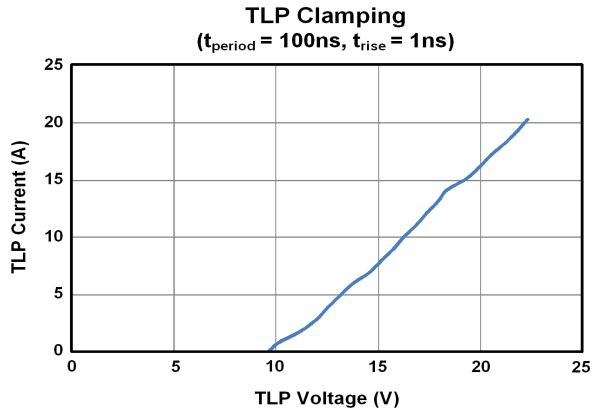

Package Dimension, DFN 0.62 x 0.32

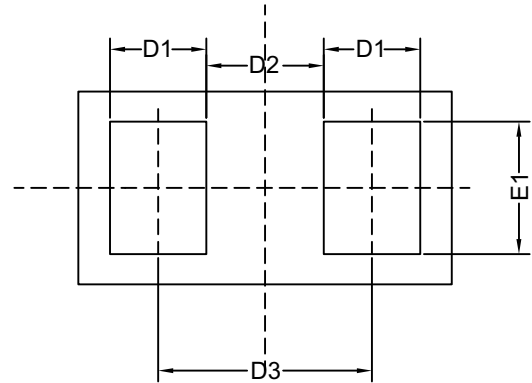
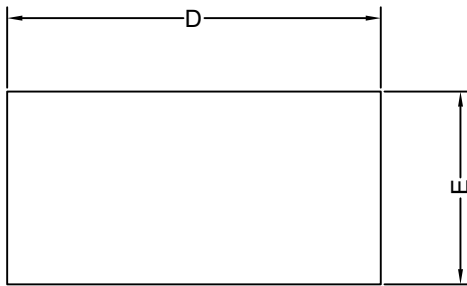

RECOMMEND LAND PATTERN

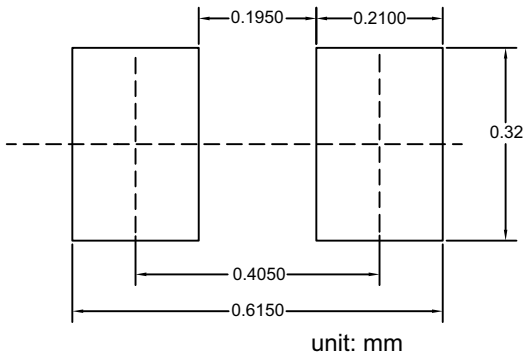

SYMBOLS	DIMENSIONS IN MILLIMETERS			DIMENSIONS IN INCHES		
	MIN	NOM	MAX	MIN	NOM	MAX
A	0.27	0.30	0.33	0.0106	0.0118	0.0130
D	0.57	0.62	0.67	0.0224	0.0244	0.0264
D1	0.11	0.16	0.21	0.0043	0.0063	0.0083
D2	0.145	0.195	0.245	0.0057	0.0077	0.0097
D3	0.305	0.355	0.405	0.0120	0.0140	0.0160
E	0.27	0.32	0.37	0.0106	0.0126	0.0146
E1	0.17	0.22	0.27	0.0067	0.0087	0.0107

NOTE

1. ALL DIMENSIONS ARE IN MILLIMETERS.
2. DIMENSIONS ARE INCLUSIVE OF PLATING.
3. PACKAGE BODY SIZES EXCLUDE MOLD FLASH AND GATE BURRS.  
MOLD FLASH AT THE NON-LEAD SIDES SHOULD BE LESS THAN 6MIL EACH.
4. CONTROLLING DIMENSIONS IN MILLIMETER.  
CONVERTED INCH DIMENSIONS ARE NOT NECESSARILY EXACT.
5. PADDLE EXPOSED ON BOTTOM.

### Tape and Reel Dimensions, DFN 0.62 x 0.32

#### Carrier Tape

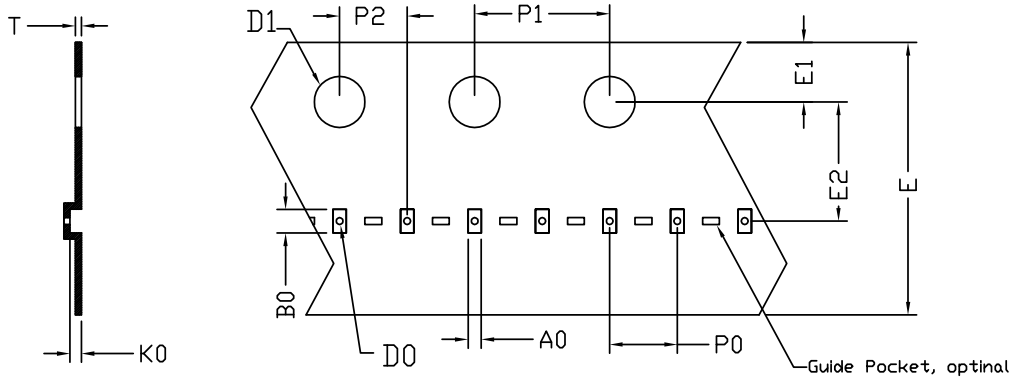

UNIT: MM

PACKAGE	A0	B0	K0	D0	D1	E	E1	E2	P0	P1	P2	T
DFN0.62x0.32 (8 mm)	0.39 ±0.03	0.69 ±0.03	0.34 +0.03 -0.01	0.20 ±0.05	1.50 +0.1 -0.0	8.00 ±0.10	1.75 ±0.10	3.50 ±0.03	2.00 ±0.05	4.00 ±0.05	2.00 ±0.05	0.20 ±0.05

#### Reel

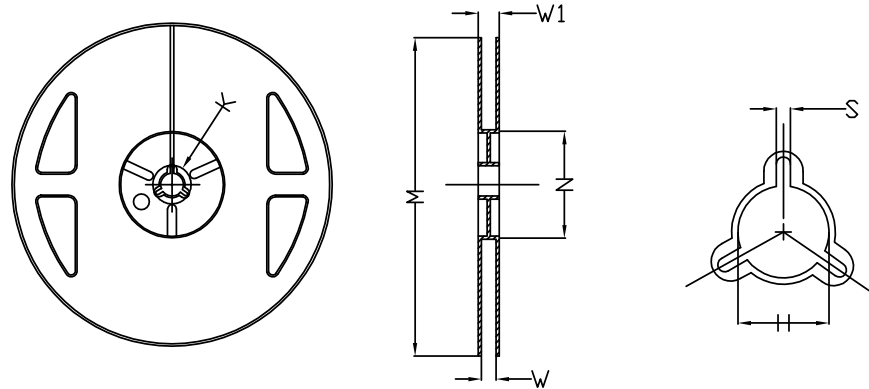

UNIT: MM

TAPE SIZE	REEL SIZE	M	N	W	W1	H	K	S
8 mm	Ø180	Ø180 +0 -3	Ø60 +1 -0	9.0 ±0.3	11.4 ±1.0	Ø13.0 ±0.2	Ø21.0 ±0.5	2.0 ±0.5

#### Leader / Trailer & Orientation

Unit Per Reel: 10000pcs

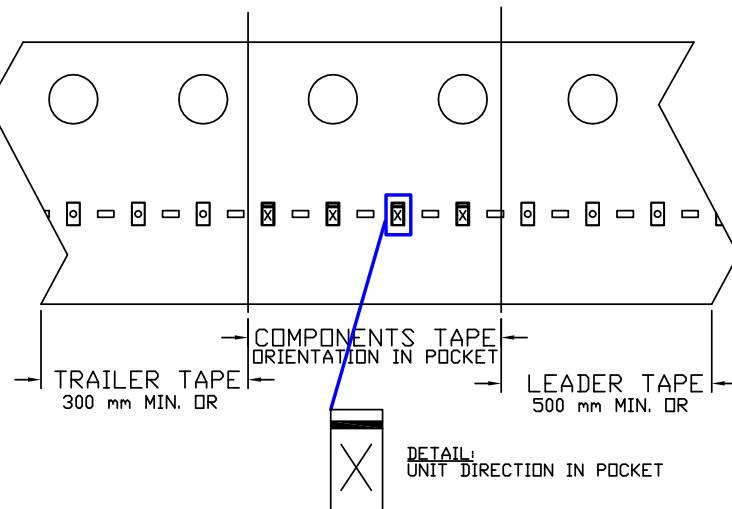

**Part Marking**

**DFN0.62x0.32**

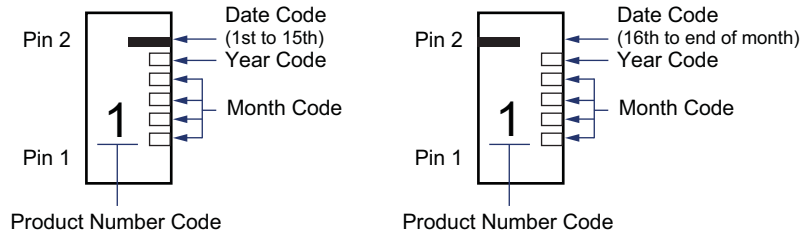

**Alpha & Omega Semiconductor reserves the right to make changes to this data sheet at any time without notice.**

**LIFE SUPPORT POLICY**

**ALPHA & OMEGA SEMICONDUCTOR PRODUCTS ARE NOT AUTHORIZED FOR USE AS CRITICAL COMPONENTS IN LIFE SUPPORT DEVICES OR SYSTEMS.**

As used herein:

1. Life support devices or systems are devices or systems which, (a) are intended for surgical implant into the body or (b) support or sustain life, and (c) whose failure to perform when properly used in accordance with instructions for use provided in the labeling, can be reasonably expected to result in a significant injury of the user.
2. A critical component in any component of a life support, device, or system whose failure to perform can be reasonably expected to cause the failure of the life support device or system, or to affect its safety or effectiveness.

单击下面可查看定价，库存，交付和生命周期等信息

[>>AOS\(万国半导体\)](#)