

General Description

The AOZ8360DI is a series of 1-channel unidirectional high surge transient voltage suppressors designed to protect power rails such as battery and VBUS from damaging ESD or surge events. The VRWM range is from 7.5V to 24V.

This device consists a unidirectional TVS diode in a single package. During transient events, the diode directs the transient to either the positive side of the power supply line or to ground.

The AOZ8360DI provides low clamping voltage making it ideally suited for power rail protection in mobile and computing devices.

The AOZ8360DI comes in a RoHS compliant and Halogen Free 2.0 mm×2.0 mm×0.55 mm package and is rated for -40°C to +125°C junction temperature range.

Features

- ESD protection for high-speed data lines:
 - IEC 61000-4-2 (ESD) $\pm 30\text{kV}$ (air and contact)
 - Air discharge: $\pm 30\text{kV}$
 - Contact discharge: $\pm 30\text{kV}$
- IEC 61000-4-5 (Lightning, 8/20 μs) ± 300 to $\pm 110\text{A}$
- Low clamping voltage
- VRWM: 7.5, 12, 15, 18, 20, 22, 24V

Applications

- Battery
- VBUS
- Mobile phone
- Notebook computers



Typical Application

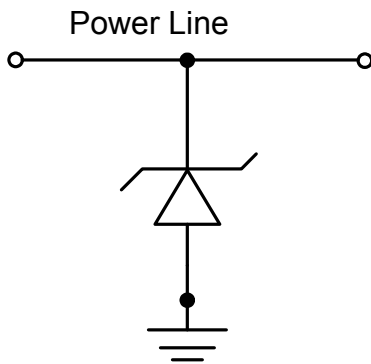

Pin Configuration

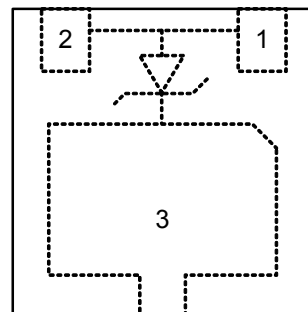

DFN2.0x2.0_3L
(Top View)

Ordering Information

| Part Number | Ambient Temperature Range | Package | Environmental |
|--------------|---------------------------|-----------|---------------|
| AOZ8360DI-07 | -40°C to +125°C | DFN2×2-3L | Green Product |
| AOZ8360DI-12 | | | |
| AOZ8360DI-15 | | | |
| AOZ8360DI-18 | | | |
| AOZ8360DI-20 | | | |
| AOZ8360DI-22 | | | |
| AOZ8360DI-24 | | | |



AOS Green Products use reduced levels of Halogens, and are also RoHS compliant.

Please visit www.aosmd.com/media/AOSGreenPolicy.pdf for additional information.

Absolute Maximum Ratings

Exceeding the Absolute Maximum ratings may damage the device.

| Parameter | Rating |
|---|------------------|
| Working Voltage | 7.5V to 24V |
| Storage Temperature (T _S) | -65 °C to +150°C |
| ESD Rating per IEC61000-4-2, contact ⁽¹⁾ | ±30 kV |
| ESD Rating per IEC61000-4-2, air ⁽¹⁾ | ±30 kV |
| 8/20µs Surge IEC61000-4-5 Peak Pulse Power | 4250 W |
| 8/20µs Surge IEC61000-4-5 Peak Pulse Current | ± 300 to 110 A |

Notes:

- IEC 61000-4-2 discharge with C_{Discharge} = 150pF, R_{Discharge} = 330Ω.
- Human Body Discharge per MIL-STD-883, Method 3015 C_{Discharge} = 100pF, R_{Discharge} = 1.5kΩ.

Maximum Operating Ratings

| Parameter | Rating |
|--|-----------------|
| Junction Temperature (T _J) | -40°C to +125°C |

Electrical Characteristics

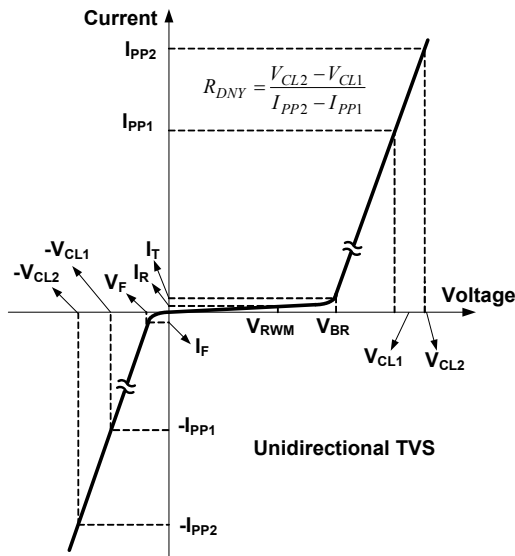

T_A = 25°C unless otherwise specified.

| Symbol | Parameter |
|------------------|---------------------------------|
| V _{RWM} | Maximum Reverse Working Voltage |
| V _{BR} | Breakdown Voltage |
| I _R | Leakage Current |
| I _{PP} | Peak Pulse Current |
| V _{CL} | Clamping Voltage |
| R _{DNY} | Dynamic Resistance |
| I _T | Test Current |
| V _F | Forward Voltage |

| Part Number | V _{RWM} (V) | V _{BR} at 1mA (V) | | | I _R at Max. V _{RWM} (nA) | | Rated I _{PP} (A) ⁽³⁾ | V _{CL} at 1A (V) ⁽³⁾⁽⁴⁾ | V _{CL} at I _{PP_RATED} (V) ⁽³⁾⁽⁴⁾ | R _{DNY} 1A to I _{PP_RATED} (Ω) ⁽³⁾⁽⁴⁾ | C _J at 1MHz (pF) ⁽⁴⁾ |
|--------------|-------------------------|----------------------------------|------|------|--|-----|--|---|--|--|--|
| | Max | Min | Typ | Max | Typ | Max | Max | Max | Max | Typ | Typ |
| AOZ8360DI-07 | 7.5 | 8 | 9 | 10 | 10 | 800 | 300 | 11 | 15 | 0.01 | 2700 |
| AOZ8360DI-12 | 12 | 13.2 | 14.5 | 16.5 | 10 | 800 | 220 | 16.5 | 23 | 0.02 | 1350 |
| AOZ8360DI-15 | 15 | 16.5 | 18 | 19.5 | 10 | 800 | 180 | 20 | 27 | 0.04 | 1100 |
| AOZ8360DI-18 | 18 | 19 | 21 | 23 | 15 | 800 | 165 | 23 | 31.5 | 0.05 | 950 |
| AOZ8360DI-20 | 20 | 21.5 | 23.5 | 25.5 | 23 | 800 | 135 | 28 | 35 | 0.05 | 850 |
| AOZ8360DI-22 | 22 | 23.5 | 25.5 | 27.5 | 20 | 800 | 135 | 29 | 36 | 0.05 | 800 |
| AOZ8360DI-24 | 24 | 26 | 28 | 30 | 20 | 800 | 110 | 33 | 41 | 0.06 | 730 |

Notes:

- 3. These specifications are guaranteed by design and characterization.
- 4. Per IEC61000-4-5 Surge 1.2/50μs (8/20μs).

Package Dimensions, DFN2x2-3L, EP1_S

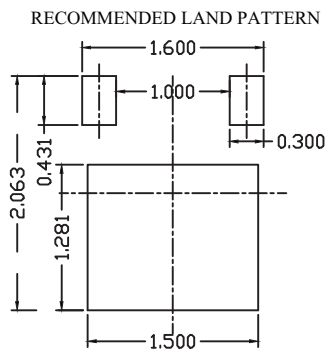
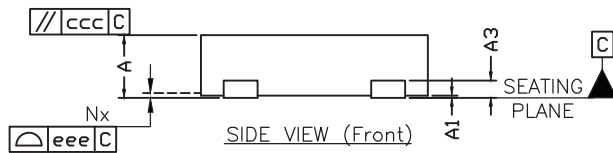
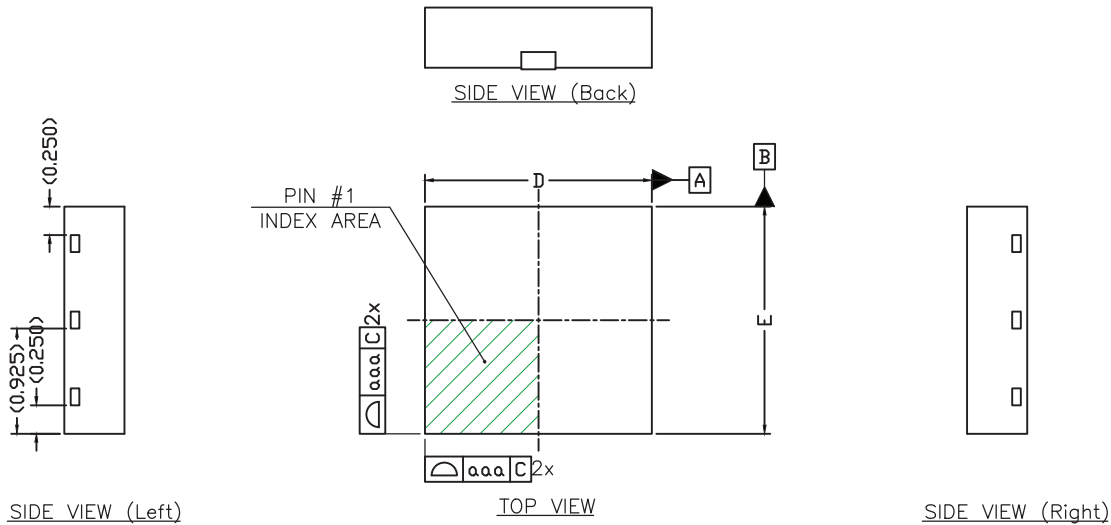

UNIT: mm

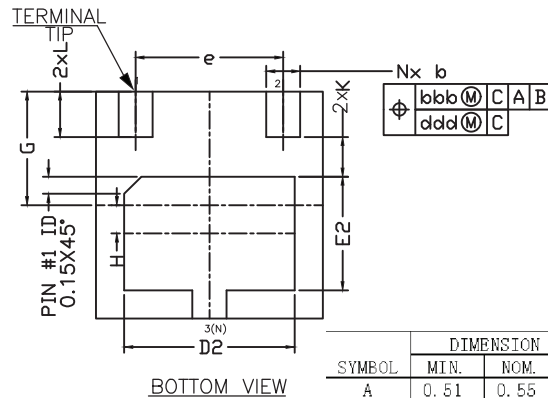

| SYMBOL | DIMENSION IN MM | | | DIMENSION IN INCH | | |
|--------|-----------------|---------|------|-------------------|----------|-------|
| | MIN. | NOM. | MAX. | MIN. | NOM. | MAX. |
| A | 0.51 | 0.55 | 0.60 | 0.020 | 0.022 | 0.024 |
| A1 | 0.00 | 0.02 | 0.05 | 0.000 | 0.001 | 0.002 |
| A3 | --- | 0.15Ref | --- | --- | 0.006Ref | --- |
| b | 0.25 | 0.30 | 0.35 | 0.010 | 0.012 | 0.014 |
| D | 1.90 | 2.00 | 2.10 | 0.075 | 0.079 | 0.083 |
| E | 1.90 | 2.00 | 2.10 | 0.075 | 0.079 | 0.083 |
| e | 1.30 BSC | | | 0.051 BSC | | |
| D2 | 1.40 | 1.50 | 1.60 | 0.055 | 0.059 | 0.063 |
| E2 | 0.90 | 1.00 | 1.10 | 0.035 | 0.039 | 0.043 |
| K | 0.20 | --- | --- | 0.008 | --- | --- |
| L | 0.35 | 0.40 | 0.45 | 0.014 | 0.016 | 0.018 |
| G | 0.95 | 1.00 | 1.05 | 0.037 | 0.039 | 0.041 |
| H | 0.20 | 0.25 | 0.30 | 0.008 | 0.010 | 0.012 |
| aaa | 0.05 | | | 0.002 | | |
| bbb | 0.10 | | | 0.004 | | |
| ccc | 0.10 | | | 0.004 | | |
| ddd | 0.05 | | | 0.002 | | |
| eee | 0.08 | | | 0.003 | | |

NOTE:

1. Dimensioning and tolerancing conform to ASME Y14.5-2009.
2. All dimensions are in millimeters.
3. N is the total number of terminals. Here N is equal to 3.
4. The location of the marked terminal #1 identifier is within the hatched area.
5. Dimension b applies to the metallized terminal. If the terminal has a radius on the other end of it, dimension b should not be measured in that radius area.
6. Coplanarity applies to the terminals and all other bottom surface metallization.

Tape and Reel Dimension, DFN2x2-3L, EP1_S

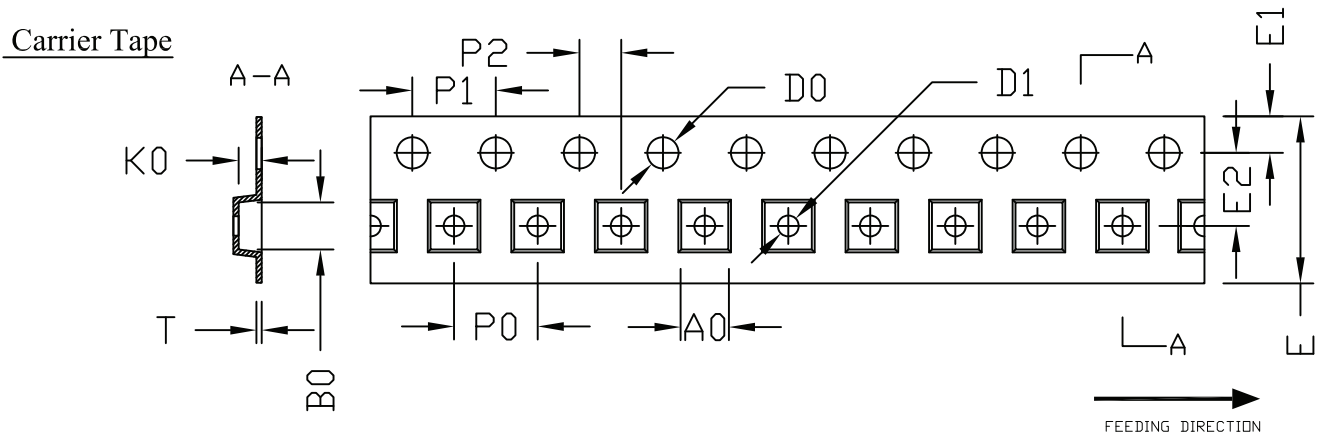

UNIT: MM

| OPTION | PACKAGE | A0 | B0 | K0 | D0 | D1 | E | E1 | E2 | P0 | P1 | P2 | T |
|--------|----------------------|---------------|---------------|---------------|---------------------|---------------------|------------------------|---------------|---------------|---------------|---------------|---------------|----------------|
| 1 | DFN 2X2 DFN 2X2A | 2.25 ±0.05 | 2.25 ±0.05 | 1.00 ±0.05 | 1.50 +0.10 -0 | 1.00 +0.25 -0 | 8.00 +0.30 -0.10 | 1.75 ±0.10 | 3.50 ±0.05 | 4.00 ±0.10 | 4.00 ±0.10 | 2.00 ±0.05 | 0.254 ±0.02 |
| 2 | DFN 2X2B DFN 2X2C | 2.30 ±0.20 | 2.30 ±0.20 | 1.00 ±0.20 | 1.50 +0.10 -0 | 1.00 MIN. | 8.00 +0.30 -0.10 | 1.75 ±0.10 | 3.50 ±0.05 | 4.00 ±0.20 | 4.00 ±0.20 | 2.00 ±0.05 | 0.30 ±0.05 |

REEL

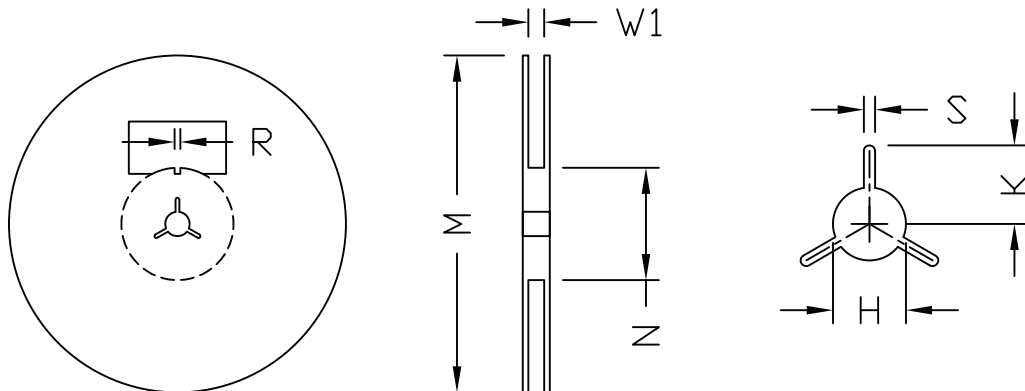

UNIT: MM

| TAPE SIZE | REEL SIZE | M | N | W1 | H | S | K | R |
|-----------|-----------|-----------------|---------------|---------------------|---------------|-------------|--------------|--------------|
| 8 | ø180 | ø180.0 ±0.50 | 60.0 ±0.50 | 8.4 +1.5 -0.0 | 13.0 ±0.20 | 1.5 MIN. | 13.5 MIN. | 3.0 ±0.50 |

TAPE

Leader / Trailer
& Orientation

Unit Per Reel:
3000pcs

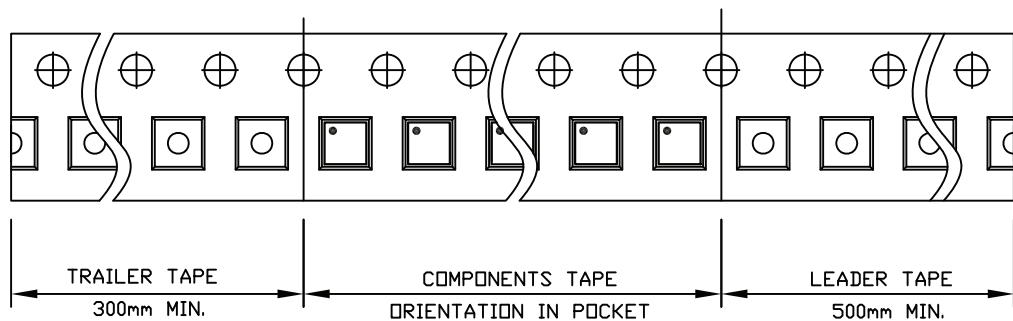

Part Marking

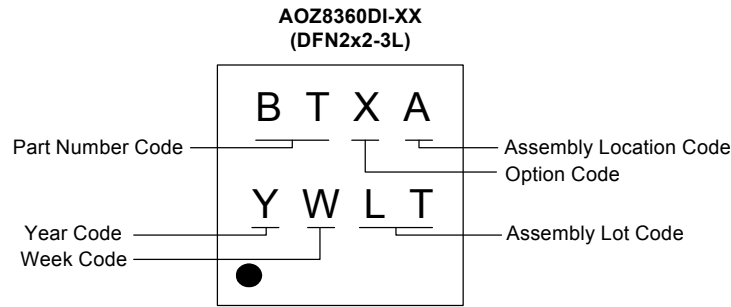

| Part Number | Option Code |
|--------------|-------------|
| AOZ8360DI-07 | 7 |
| AOZ8360DI-12 | C |
| AOZ8360DI-15 | F |
| AOZ8360DI-18 | K |
| AOZ8360DI-20 | N |
| AOZ8360DI-22 | R |
| AOZ8360DI-24 | T |

LEGAL DISCLAIMER

Alpha and Omega Semiconductor makes no representations or warranties with respect to the accuracy or completeness of the information provided herein and takes no liabilities for the consequences of use of such information or any product described herein. Alpha and Omega Semiconductor reserves the right to make changes to such information at any time without further notice. This document does not constitute the grant of any intellectual property rights or representation of non-infringement of any third party's intellectual property rights.

LIFE SUPPORT POLICY

ALPHA AND OMEGA SEMICONDUCTOR PRODUCTS ARE NOT AUTHORIZED FOR USE AS CRITICAL COMPONENTS IN LIFE SUPPORT DEVICES OR SYSTEMS.

As used herein:

1. Life support devices or systems are devices or systems which, (a) are intended for surgical implant into the body or (b) support or sustain life, and (c) whose failure to perform when properly used in accordance with instructions for use provided in the labeling, can be reasonably expected to result in a significant injury of the user.
2. A critical component in any component of a life support, device, or system whose failure to perform can be reasonably expected to cause the failure of the life support device or system, or to affect its safety or effectiveness.

单击下面可查看定价，库存，交付和生命周期等信息

[>>AOS\(万国半导体\)](#)