

General Description

The AOZ8634UMT-03 is a 4-channel transient voltage suppressor array designed to protect high speed data lines such as SD and SIM Cards in mobile phones from damaging ESD events.

This device incorporates eight surge rated, low capacitance steering diodes and a TVS in a single package. During transient conditions, the steering diodes direct the transient to either the positive side of the power supply line or to ground.

The AOZ8634UMT-03 comes in a RoHS compliant and Halogen Free 1.3mm x 0.8mm x 0.4 mm package and is rated for -40°C to +125°C junction temperature range.

Features

- ESD protection for high-speed data lines:
 - IEC 61000-4-2, ESD immunity:
 - Air discharge: ± 30 kV
 - Contact discharge: ± 30 kV
 - IEC61000-4-5 (Lightning, 8/20 μ s): ± 16 A
- Protects four I/O lines
- Low capacitance between I/O to GND: 3 pF
- Low clamping voltage
- Low operating voltage: 3.3 V

Applications

- SD and SIM cards
- Monitors and flat panel displays
- Set-top box
- Mobile Phone
- Notebook computers



Typical Applications

SIM Card Protection

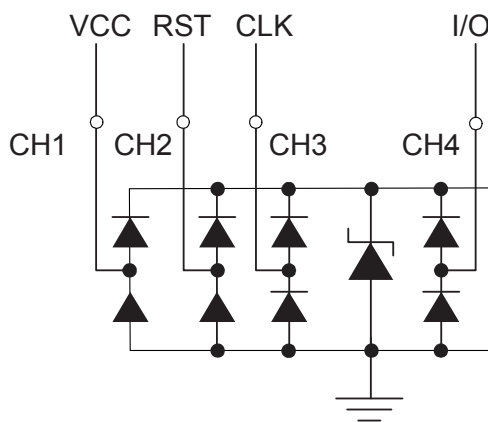

SD Card Protection

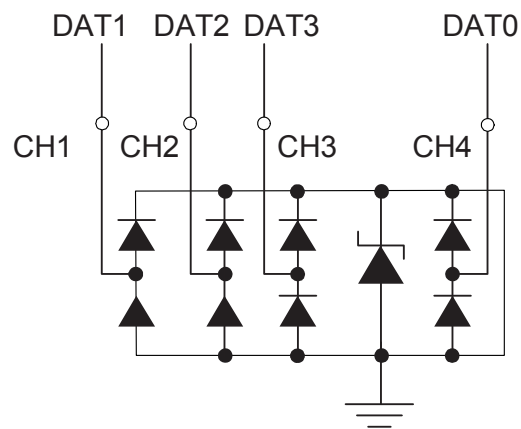

Ordering Information

Part Number	Ambient Temperature Range	Package	Environmental
AOZ8634UMT-03	-40°C to +125°C	DFN1.3mm x0.8mm_6L	Green Product



AOS Green Products use reduced levels of Halogens, and are also RoHS compliant. Please visit www.aosmd.com/media/AOSGreenPolicy.pdf for additional information.

Pin Configuration

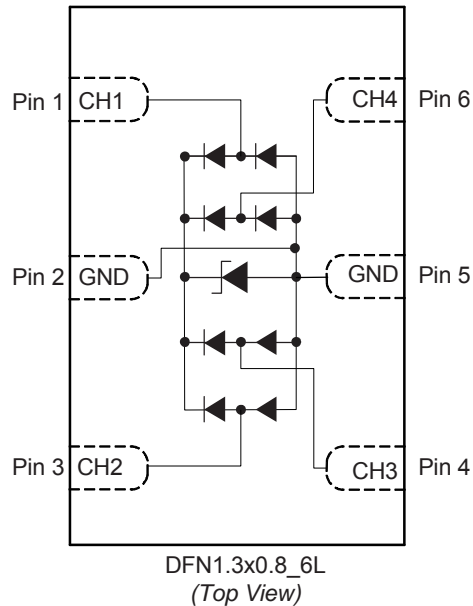

Absolute Maximum Ratings

Exceeding the Absolute Maximum ratings may damage the device.

Parameter	Rating
Storage Temperature (T_S)	-65°C to +150°C
ESD Rating per IEC61000-4-2, contact ⁽¹⁾	±30 kV
ESD Rating per IEC61000-4-2, air ⁽¹⁾	±30 kV
Peak Pulse Current per IEC61000-4-5 Surge 8/20 μ s	±16 A
Peak Pulse Power per IEC61000-4-5 Surge 8/20 μ s	160 W

Notes:

- IEC 61000-4-2 discharge with $C_{Discharge} = 150\text{pF}$, $R_{Discharge} = 330\ \Omega$.
- Human Body Discharge per MIL-STD-883, Method 3015 $C_{Discharge} = 100\ \text{pF}$, $R_{Discharge} = 1.5\ \text{k}\Omega$.

Maximum Operating Ratings

Parameter	Rating
Junction Temperature (T_J)	-40°C to +125°C

Electrical Characteristics

T_A = 25°C, unless otherwise specified. Any I/O pin to GND.

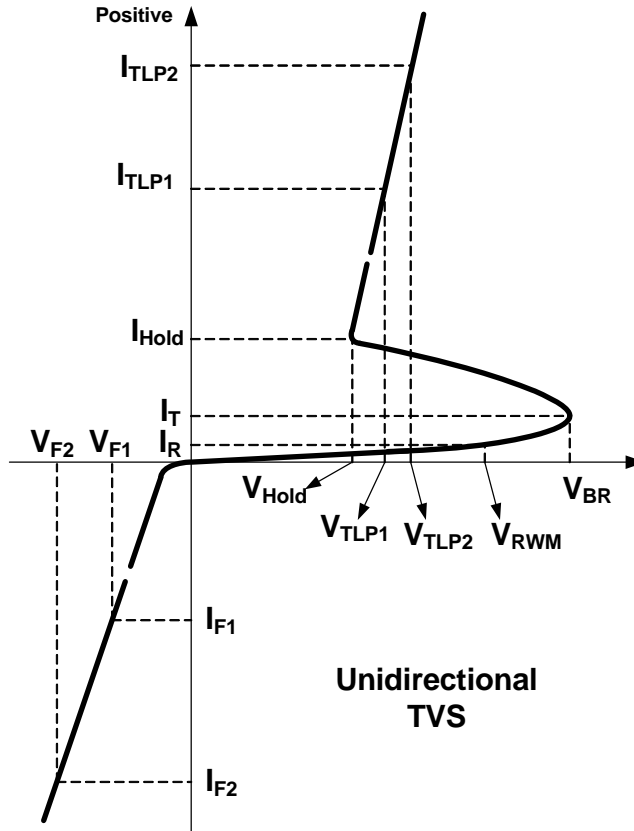

Symbol	Parameter	Conditions	Min.	Typ.	Max	Units
V _{RWM}	Reverse Working Voltage	I/O pin to ground			3.3	V
V _{BR}	Reverse Breakdown Voltage	I _T = 100 μA	5.5	6.5	8	V
I _R	Reverse Leakage Current	V _T = Max. V _{RWM}		1	100	nA
V _F	Forward Voltage	I _F = 15mA		0.85		V
V _{CL}	Clamping Voltage ⁽³⁾⁽⁴⁾ (100ns Transmission Line Pulse)	I _{TLP} = 1 A I _{TLP} = -1 A		5 -1.2	6.5 -2	V
		I _{TLP} = 16 A I _{TLP} = -16 A		5.8 -3.5	7.5 -4.5	
R _{DNY}	Dynamic Resistance ⁽³⁾⁽⁴⁾	I _{TLP} = 8 A to 16 A I _{TLP} = -8 A to -16 A		0.05 0.15		Ω
I _{PP}	Peak Pulse Current ⁽³⁾ IE61000-4-5 Surge 8/20 μs	Any I/O pin to GND GND to any I/O pin			±16	A
V _{CL}	Clamping Voltage ⁽³⁾ IEC61000-4-5 Surge 8/20 μs	I _{PP} = 2 A I _{PP} = -2 A		5 -2	6.5 -3	V
		I _{PP} = 16 A I _{PP} = -16 A		10 -8	12 -10	
C _J	Junction Capacitance	V _{I/O} = 0V, f = 1 MHz, Any I/O pin to GND		3	8	pF

Notes:

- 3. These specifications are guaranteed by design and characterization.
- 4. Measurements performed using a 100ns Transmission Line Pulse (TLP) system.

Typical Performance Characteristics

Positive Transmission Line Pulse
($t_p = 100\text{ns}$, $t_r = 0.2\text{ns}$)

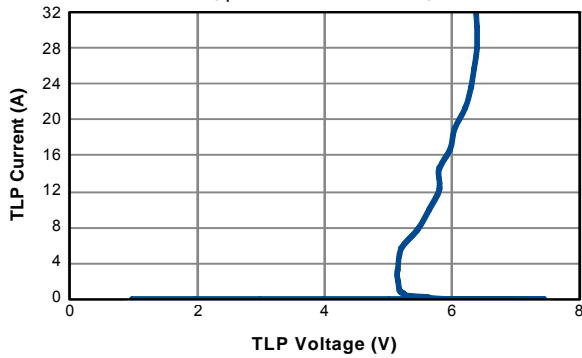

Negative Transmission Line Pulse
($t_p = 100\text{ns}$, $t_r = 0.2\text{ns}$)

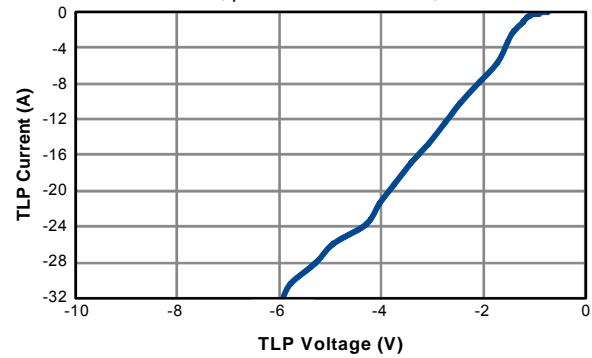

Typical Variations of C_j vs. Input Voltage

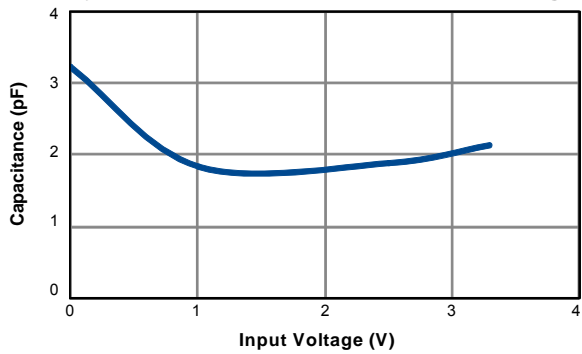

IEC61000-4-5 Surge 8/20 μ s

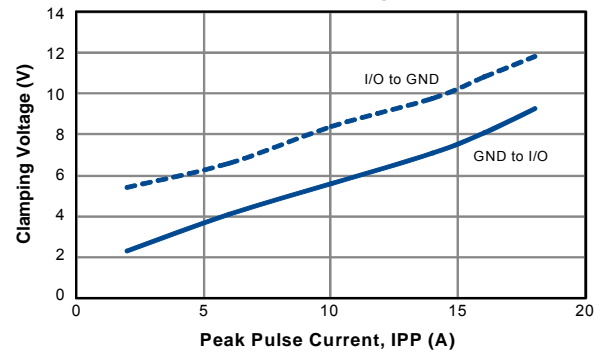

Package Dimensions, DFN1.3x0.8_6L

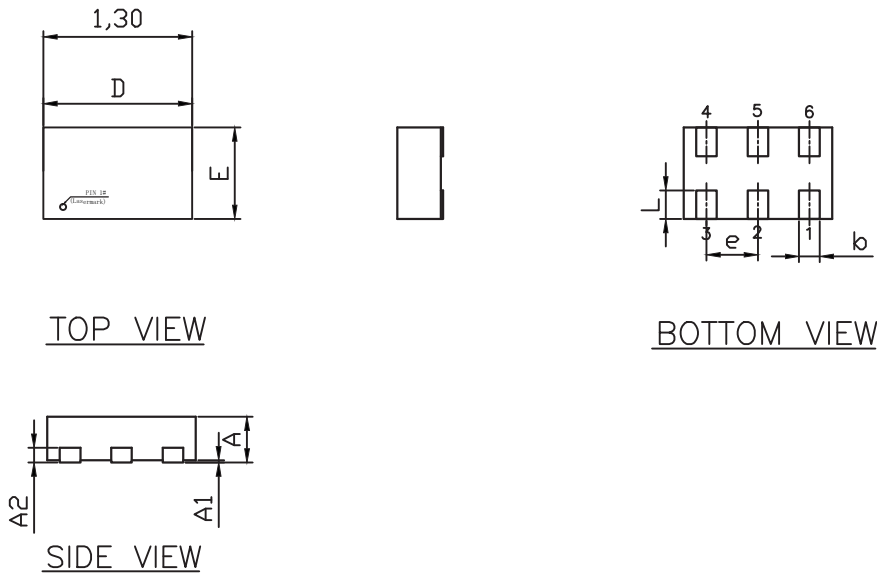

RECOMMENDED LAND PATTERN

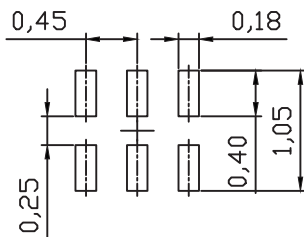

SYMBOLS	DIMENSIONS IN MILLIMETERS			DIMENSIONS IN INCHES		
	MIN	NOM	MAX	MIN	NOM	MAX
A	0.37	0.40	0.43	0.015	0.016	0.017
A1	0.00	0.02	0.05	0.000	0.001	0.002
A2	0.08	0.13	0.18	0.003	0.005	0.007
b	0.13	0.18	0.23	0.005	0.007	0.009
D	1.20	1.30	1.40	0.047	0.051	0.055
E	0.70	0.80	0.90	0.028	0.031	0.035
e	0.45 BSC			0.018 BSC		
L	0.20	0.25	0.30	0.008	0.010	0.012

UNIT: mm

NOTE

1. CONTROLLING DIMENSION IS MILLIMETER.
CONVERTED INCH DIMENSIONS ARE NOT NECESSARILY EXACT.
2. LAND PATTERN DIMENSIONS ARE ONLY FOR REFERENCE.

Tape and Reel Dimensions, DFN1.3x0.8_6L

Carrier Tape

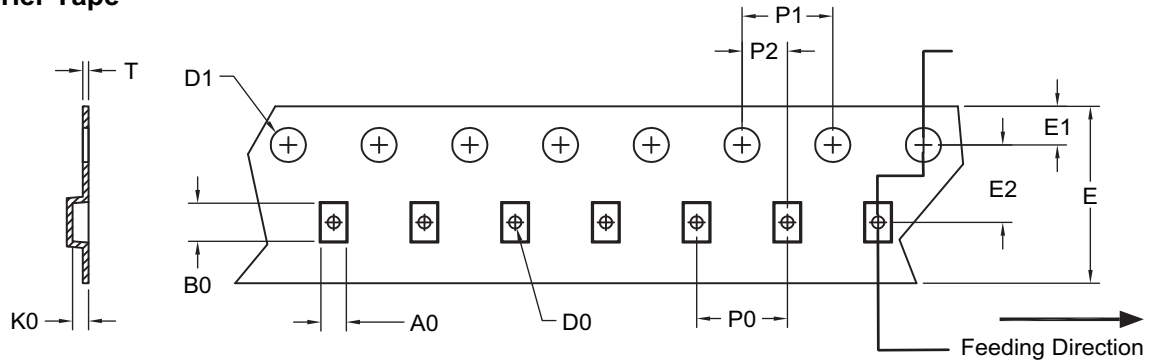

UNIT: mm

Package	A0	B0	K0	D0	D1	E	E1	E2	P0	P1	P2	T
DFN 1.3x0.8 (8mm)	1.00 ±0.05	1.50 ±0.05	0.50 ±0.05	0.50 ±0.05	1.50 ±0.10	8.00 +0.3/-0.10	1.75 ±0.10	3.50 ±0.05	4.00 ±0.10	4.00 ±0.10	2.00 ±0.05	0.20 ±0.02

Reel

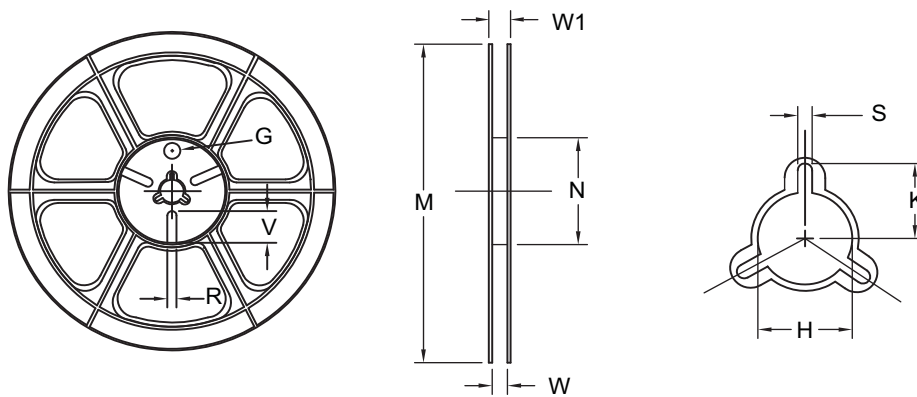

UNIT: mm

Tape Size	Reel Size	M	N	W	W1	H	K	S	E	R	R
8mm	ø178	ø178.0 ±1.0	ø60.0 ±1.0	9.0 ±0.5	—	ø13.0 +0.5/-0.2	10.25 ±0.2	2.4 ±0.1	ø9.8	—	—

Leader/Trailer & Orientation

MOQ 5kpcs/per Reel

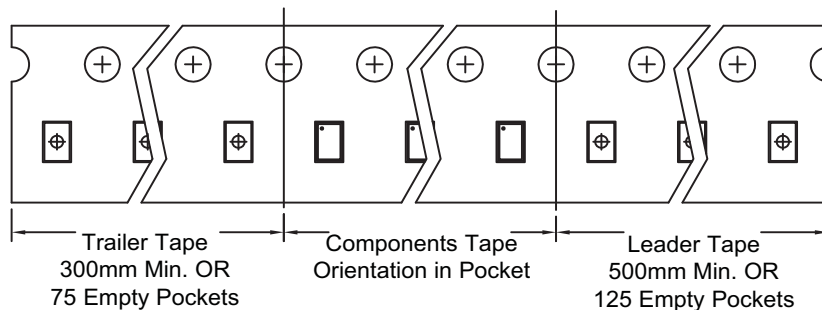

Part Marking

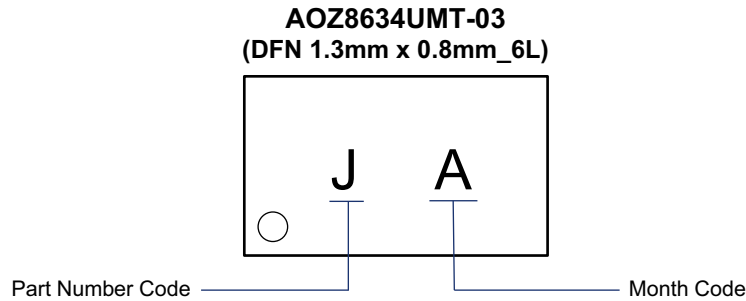

LEGAL DISCLAIMER

Alpha and Omega Semiconductor makes no representations or warranties with respect to the accuracy or completeness of the information provided herein and takes no liabilities for the consequences of use of such information or any product described herein. Alpha and Omega Semiconductor reserves the right to make changes to such information at any time without further notice. This document does not constitute the grant of any intellectual property rights or representation of non-infringement of any third party's intellectual property rights.

LIFE SUPPORT POLICY

ALPHA AND OMEGA SEMICONDUCTOR PRODUCTS ARE NOT AUTHORIZED FOR USE AS CRITICAL COMPONENTS IN LIFE SUPPORT DEVICES OR SYSTEMS.

As used herein:

- | | |
|---|---|
| <p>1. Life support devices or systems are devices or systems which, (a) are intended for surgical implant into the body or (b) support or sustain life, and (c) whose failure to perform when properly used in accordance with instructions for use provided in the labeling, can be reasonably expected to result in a significant injury of the user.</p> | <p>2. A critical component in any component of a life support, device, or system whose failure to perform can be reasonably expected to cause the failure of the life support device or system, or to affect its safety or effectiveness.</p> |
|---|---|

单击下面可查看定价，库存，交付和生命周期等信息

[>>AOS\(万国半导体\)](#)