

General Description

The AOZ8654BLT-05 is a 4-channel transient voltage suppressor designed to protect data lines such as USB2.0 and SD/SIM card from damaging ESD events.

This device incorporates 5 Unidirectional TVS diodes in a single package. During transient conditions, the bidirectional diodes direct the transient to either the positive side of the power supply line or to ground.

The AOZ8654BLT-05 provides a typical line-to-line capacitance of 3 pF and low clamping voltage making it ideally suited for data transmission protection in mobile and computing devices.

The AOZ8654BLT-05 comes in a RoHS compliant and Halogen Free AlphaDFN0.925 mm x 0.525 mm x 0.30 mm package and is rated for -40°C to +125°C junction temperature range.

Features

- ESD protection for high-speed data lines:
 - IEC 61000 IE-4-2, ESD immunity:
 - Air discharge: ±30 kV
 - Contact Discharge: ±30 kV
 - IEC 61000-4-5 (Lightning) 12 A (8/20 μs)
 - Human Body Mode: ±8 kV
- Protects four I/O lines
- Low capacitance between I/O to GND: 2.5 pF
- Low clamping voltage
- Reverse working voltage: 5.5 V

Applications

- USB 2.0, SD/SIM cards
- Mobile phones
- Notebook computers



Typical Application

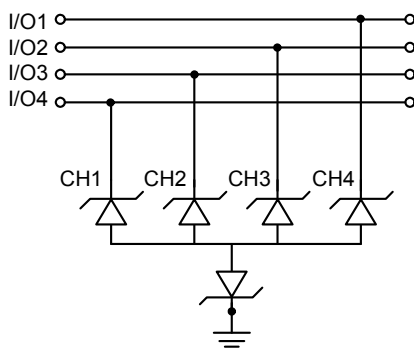

Pin Configuration

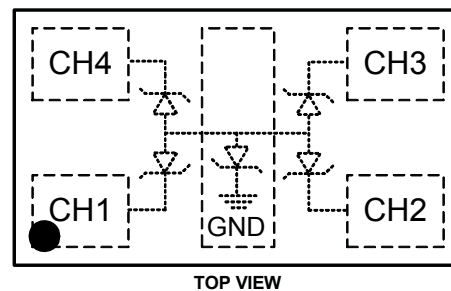

Ordering Information

Part Number	Ambient Temperature Range	Package	Environmental
AOZ8654BLT-05	-40°C to +125°C	DFN 0.925x0.525-5	Green Product



AOS Green Products use reduced levels of Halogens, and are also RoHS compliant.

Absolute Maximum Ratings

Exceeding the Absolute Maximum Ratings may damage the device.

Parameter	Rating
Storage Temperature (T _S)	-65°C to +150°C
ESD Rating per IEC61000-4-2, Contact ⁽¹⁾	±30 kV
ESD Rating per IEC61000-4-2, Air ⁽¹⁾	±30 kV
ESD Rating per Human Body Model ⁽²⁾	±8 kV
Surge Rating per IEC61000-4-5 8/20ms	12 A

Notes:

- IEC 61000-4-2 discharge with C_{Discharge} = 150 pF, R_{Discharge} = 330 Ω.
- Human Body Discharge per MIL-STD-883, Method 3015 C_{Discharge} = 100 pF, R_{Discharge} = 1.5 kΩ.

Maximum Operating Conditions

The device is not guaranteed to operate beyond the Maximum Operating Conditions.

Parameter	Rating
Junction Temperature (T _J)	-40°C to +125°C

Electrical Characteristics

T_A = 25°C unless otherwise specified.

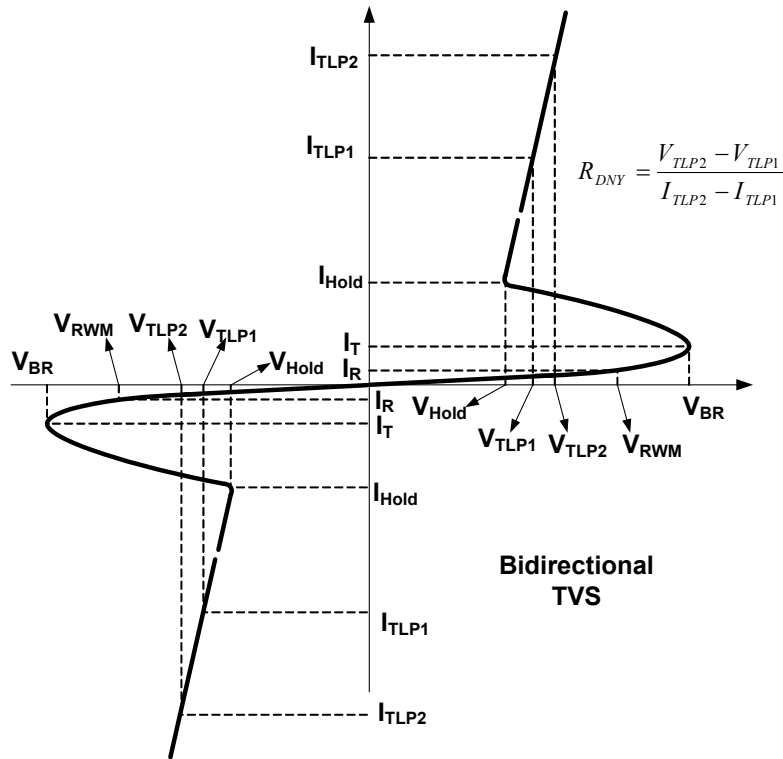

Symbol	Parameter	Conditions	Min.	Typ.	Max.	Units
V _{RWM}	Reverse Working Voltage				5.5	V
V _{BR}	Reverse Breakdown Voltage	I _T = 100 μA	6.5	9	11	V
I _R	Reverse Leakage Current	Max. V _{RWM}		1	100	nA
V _{CL}	Clamping Voltage ⁽³⁾⁽⁴⁾ (100ns Transmission Line Pulse)	I _{TLP} = 1 A		3	4	V
		I _{TLP} = 16 A		5.8	7	
		I _{TLP} = 30 A		7	8	
	Clamping Voltage ⁽³⁾ (IEC61000-4-5, 8/20 μs)	I _{PP} = 2 A		2.5	3	
		I _{PP} = 12 A		6.5	8	
R _{DNY}	Dynamic Resistance ⁽³⁾⁽⁴⁾	I _{TLP} = 1 A to 16 A		0.15		Ω
C _J	Junction Capacitance	V _{IO} = 0 V, f = 1 MHz		2.5		pF

Notes:

- 3. These specifications are guaranteed by design and characterization.
- 4. Measurements performed using a 100ns Transmission Line Pulse (TLP) system.

Typical Performance Characteristics

Positive Transmission Line Pulse
($t_p = 100\text{ns}$, $t_r = 0.2\text{ns}$)

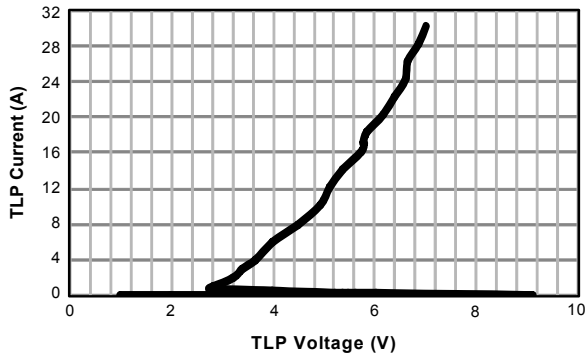

Negative Transmission Line Pulse
($t_p = 100\text{ns}$, $t_r = 0.2\text{ns}$)

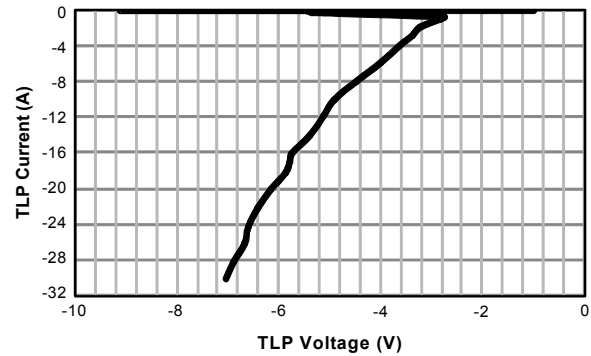

Typical Variations of CJ vs. Input Voltage

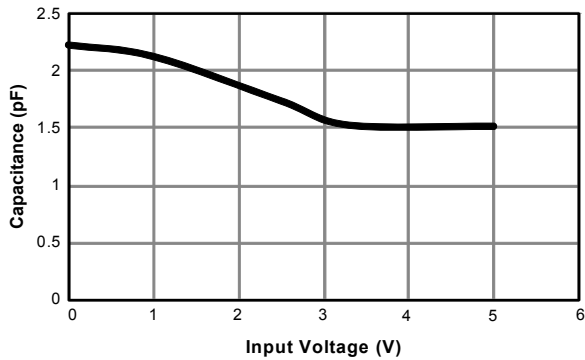

IEC61000-4-5 Surge 8/20 μs

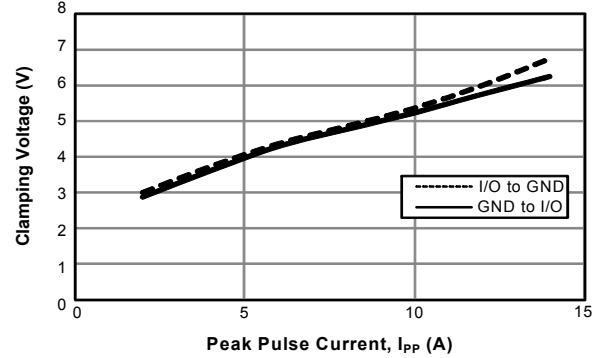

+8kV ESD Clamping Per IEC61000-4-2
(Contact, Any I/O to GND)

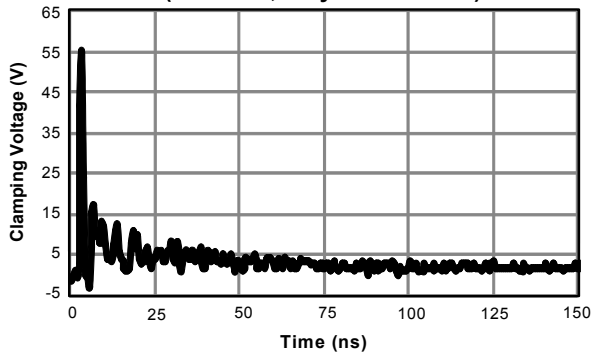

-8kV ESD Clamping Per IEC 61000-4-2
(Contact, Any I/O to GND)

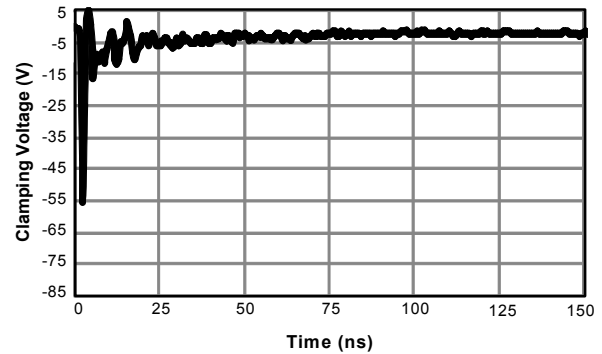

Package Dimensions, AlphaDFN0.925x0.525-5

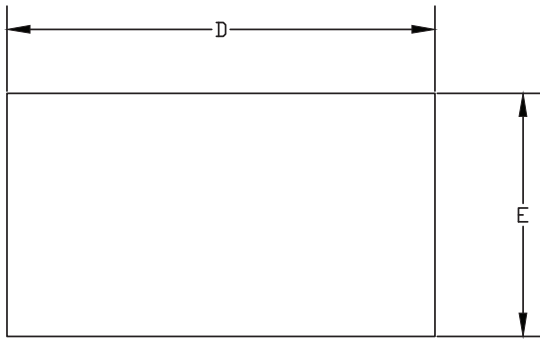

Top View

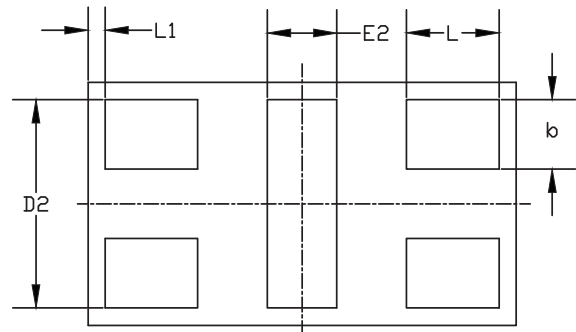

Bottom View

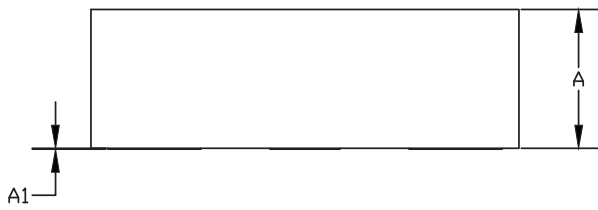

Side View

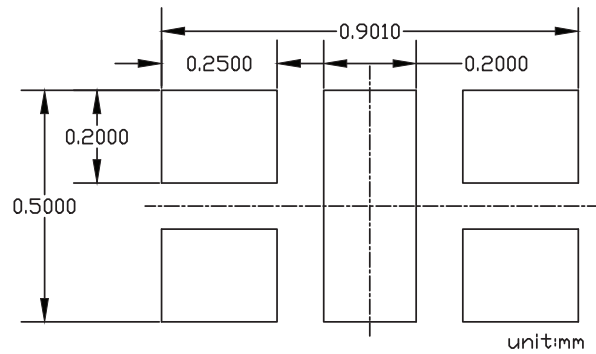

RECOMMEND LAND PATTERN

SYMBOLS	DIMENSIONS IN MILLIMETERS			DIMENSIONS IN INCHES		
	MIN	NOM	MAX	MIN	NOM	MAX
A	0.280	0.300	0.320	0.0110	0.0118	0.0126
A1	---	0.0016	---	----	0.0001	----
b	0.135	0.150	0.165	0.0053	0.0059	0.0065
D	0.495	0.525	0.555	0.0195	0.0207	0.0219
D2	---	0.450	---	----	0.0177	----
E	0.895	0.925	0.955	0.0352	0.0364	0.0376
E2	---	0.150	---	----	0.0059	----
L	0.185	0.200	0.215	0.0073	0.0079	0.0085
L1	---	0.037	---	----	0.0015	----

NOTE

1. ALL DIMENSIONS ARE IN MILLIMETERS.
2. DIMENSIONS ARE INCLUSIVE OF PLATING.
3. PACKAGE BODY SIZES EXCLUDE MOLD FLASH AND GATE BURRS.
MOLD FLASH AT THE NON-LEAD SIDES SHOULD BE LESS THAN 6MIL EACH.
4. CONTROLLING DIMENSION IS MILLIMETER. CONVERTED INCH DIMENSIONS ARE NOT NECESSARILY EXACT.
5. PADDLE EXPOSED ON BOTTOM.

Tape and Reel Dimensions, AlphaDFN0.925x0.525-5

Carrier Tape

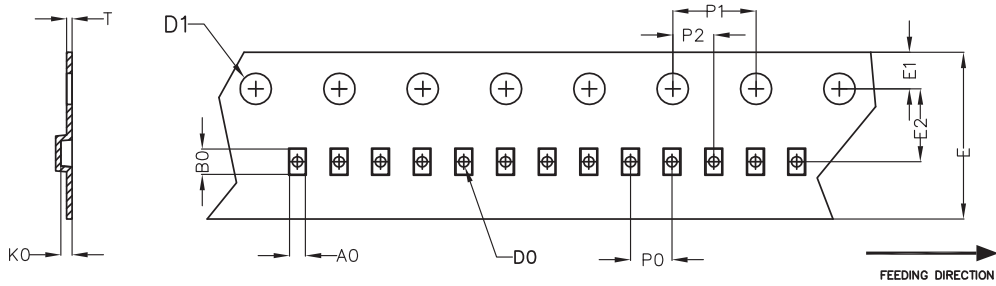

UNIT: MM

PACKAGE	A0	B0	K0	D0	D1	E	E1	E2	P0	P1	P2	T
AlphaDFN0.925x0.525 _5 (8 MM)	0.60 ±0.05	1.00 ±0.05	0.40 +0.03 -0.03	0.30 ±0.05	1.50 +0.10	8.00 +0.30 -0.10	1.75 ±0.10	3.50 ±0.05	2.00 ±0.05	4.00 ±0.10	2.00 ±0.05	0.20 ±0.02

REEL

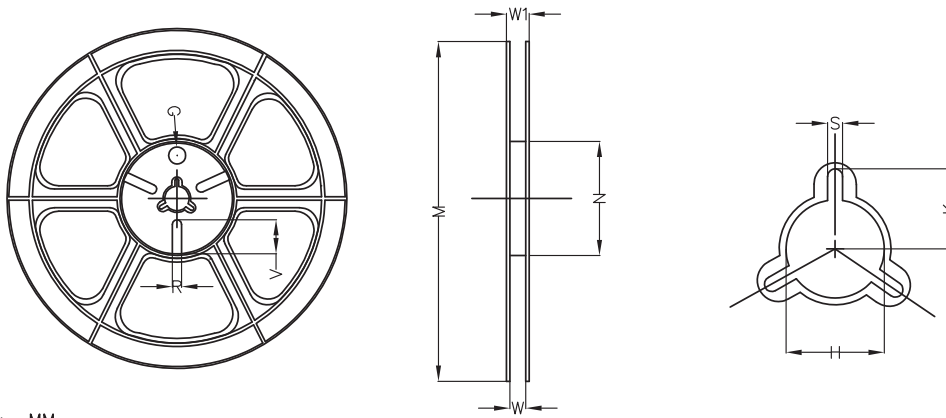

UNIT: MM

TAPE SIZE	REEL SIZE	M	N	W	W1	H	K	S	G	R	V
8 mm	ø178	ø178.00 ±1.00	ø54.00 ±0.50	9.00 ±0.30	11.40 ±1.00	ø13.00 +0.50 -0.20	10.60	2.00 ±0.50	ø9.00	5.00	18.00

TAPE

Leader / Trailer
& Orientation

Unit Per Reel:
15000pcs

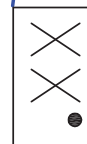
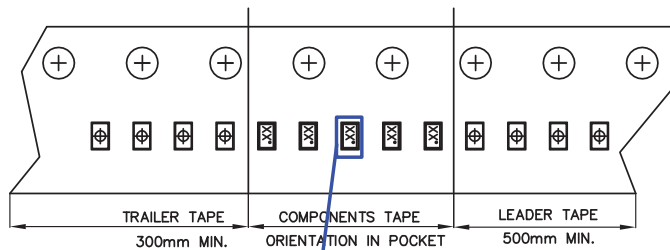

DETAIL:
UNIT DIRECTION IN POCKET

Part Marking

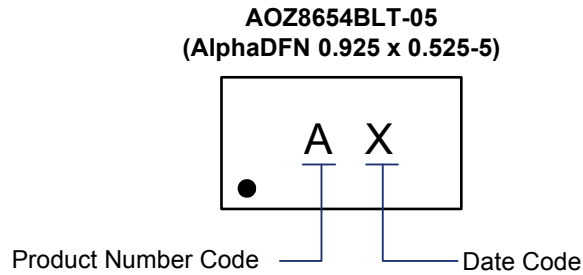

LEGAL DISCLAIMER

Alpha and Omega Semiconductor makes no representations or warranties with respect to the accuracy or completeness of the information provided herein and takes no liabilities for the consequences of use of such information or any product described herein. Alpha and Omega Semiconductor reserves the right to make changes to such information at any time without further notice. This document does not constitute the grant of any intellectual property rights or representation of non-infringement of any third party's intellectual property rights.

LIFE SUPPORT POLICY

ALPHA AND OMEGA SEMICONDUCTOR PRODUCTS ARE NOT AUTHORIZED FOR USE AS CRITICAL COMPONENTS IN LIFE SUPPORT DEVICES OR SYSTEMS.

As used herein:

- | | |
|---|---|
| <p>1. Life support devices or systems are devices or systems which, (a) are intended for surgical implant into the body or (b) support or sustain life, and (c) whose failure to perform when properly used in accordance with instructions for use provided in the labeling, can be reasonably expected to result in a significant injury of the user.</p> | <p>2. A critical component in any component of a life support, device, or system whose failure to perform can be reasonably expected to cause the failure of the life support device or system, or to affect its safety or effectiveness.</p> |
|---|---|

单击下面可查看定价，库存，交付和生命周期等信息

[>>AOS\(万国半导体\)](#)