

General Description

The AOZ8851ADI is an ultra low capacitance one-line bi-directional transient voltage suppressor diode designed to protect high speed data lines and voltage sensitive electronics from high transient conditions and ESD.

The AOZ8851ADI comes in an RoHS compliant DFN package and is rated over a -40°C to +125°C ambient temperature range.

The ultra-small 0.62 x 0.32 x 0.3mm DFN package makes it ideal for applications where PCB space is a premium. The small size and high ESD protection makes it ideal for protecting voltage sensitive electronics from high transient conditions and ESD.

Features

- ESD protection for high-speed data lines:
 - IEC 61000-4-2 (ESD) immunity:
 - Air discharge: ±15 kV
 - Contact discharge: ±8 kV
 - IEC61000-4-5 (Surge 8/20 μs)
 - 1.5 A (VRWM=18V)
 - 1.3 A (VRWM=20V)
 - 1.2 A (VRWM=24V)
- Human Body Model (HBM) ±8 kV
- Bidirectional TVS
- Ultra low capacitance: 0.4 pF
- Maximum reverse working voltage: 18 V, 20 V, 24V
- Pb-free device

Applications

- USB Type-C
- Mobile phone
- Notebook computers
- Portable devices
- Digital cameras



Typical Application

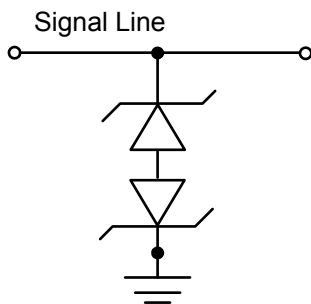

Pin Configuration

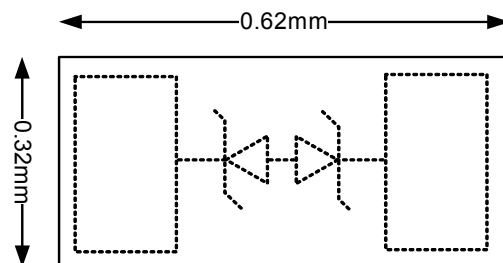

Ordering Information

Part Number	Ambient Temperature Range	Package	Environmental
AOZ8851ADI-18	-40 °C to +125 °C	DFN 0.62 x 0.32	Green Product
AOZ8851ADI-20			
AOZ8851ADI-24			



AOS Green Products use reduced levels of Halogens, and are also RoHS compliant. Please visit www.aosmd.com/media/AOSGreenPolicy.pdf for additional information.

Absolute Maximum Ratings

Exceeding the Absolute Maximum Ratings may damage the device.

Parameter	Rating		
	AOZ8851ADI-18	AOZ8851ADI-20	AOZ8851ADI-24
Any Pin to Pin	18 V	20 V	24 V
Peak Pulse Current (I_{PP}), $t_P = 8/20\mu s$	1.5 A	1.3 A	1.2 A
Peak Pulse Power (P_{PP}), $t_P = 8/20\mu s$	50 W	50 W	50 W
Storage Temperature (T_S)	-65°C to +150°C	-65°C to +150°C	-65°C to +150°C
ESD Rating per IEC61000-4-2, Contact ⁽¹⁾	±8 kV	±8 kV	±8 kV
ESD Rating per IEC61000-4-2, Air ⁽¹⁾	±15 kV	±15 kV	±15 kV
ESD Rating per Human Body Model ⁽²⁾	±8 kV	±8 kV	±8 kV

Notes:

- IEC 61000-4-2 discharge with $C_{Discharge} = 150 \text{ pF}$, $R_{Discharge} = 330 \Omega$.
- Human Body Discharge per MIL-STD-883, Method 3015 $C_{Discharge} = 100 \text{ pF}$, $R_{Discharge} = 1.5 \text{ k}\Omega$.

Maximum Operating Conditions

The device is not guaranteed to operate beyond the Maximum Operating Conditions.

Parameter	Rating
Junction Temperature (T_J)	-40°C to +125°C

Electrical Characteristics

T_A = 25°C unless otherwise specified.

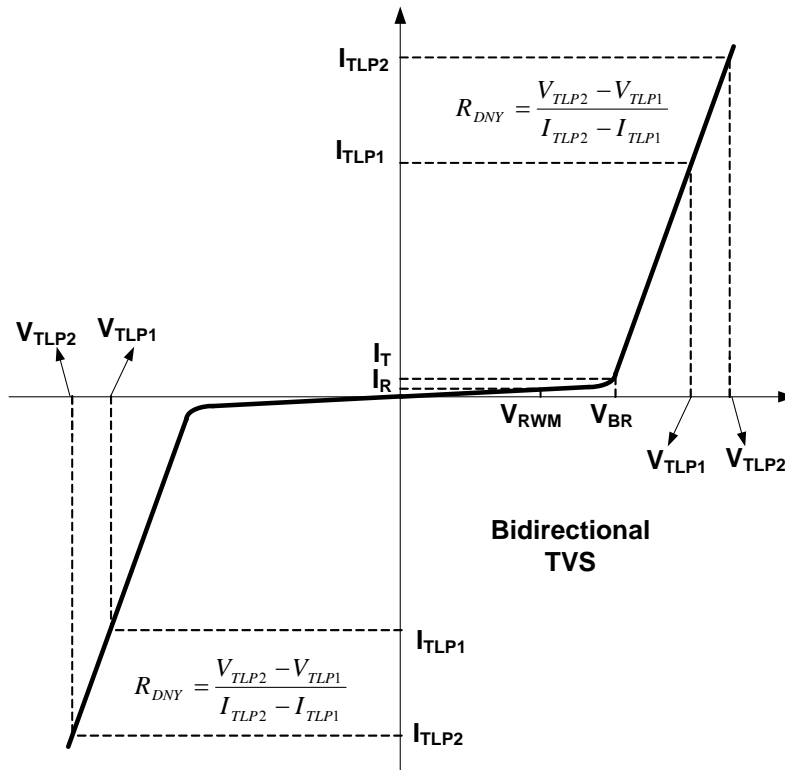

AOZ8851ADI-18						
Symbol	Parameter	Conditions	Min.	Typ.	Max.	Units
V _{RWM}	Reverse Working Voltage				18	V
V _{BR}	Reverse Breakdown Voltage	I _T = 1mA	20	23	25	V
I _R	Reverse Leakage Current	Max. V _{RWM}		1	100	nA
V _{CL}	Clamping Voltage ^(3,4) (100ns Transmission Line Pulse)	I _{TLP} =1A		26	30	V
		I _{TLP} =14A		76	88	
	Clamping Voltage ⁽³⁾ (IEC61000-4-5 Surge 8/20µs)	I _{PP} =1A		30	35	
R _{DNY}	Dynamic Resistance ^(3,4)	I _{TLP} =1 to 14A		4		Ω
C _J	Junction Capacitance	V _{IO} =0V, f=1MHz		0.4	0.7	pF

Electrical Characteristics (Continued)
 $T_A = 25^\circ\text{C}$ unless otherwise specified.

AOZ8851ADI-20						
Symbol	Parameter	Conditions	Min.	Typ.	Max.	Units
V_{RWM}	Reverse Working Voltage				20	V
V_{BR}	Reverse Breakdown Voltage	$I_T = 1\text{mA}$	22	25	28	V
I_R	Reverse Leakage Current	Max. V_{RWM}		1	100	nA
V_{CL}	Clamping Voltage ^(3,4) (100ns Transmission Line Pulse)	$I_{TLP}=1\text{A}$		30	35	V
		$I_{TLP}=10\text{A}$		70	77	
	Clamping Voltage ⁽³⁾ (IEC61000-4-5 Surge 8/20 μs)	$I_{PP}=1\text{A}$		36	42	
R_{DNY}	Dynamic Resistance ^(3,4)	$I_{TLP}=1$ to 10A		4		Ω
C_J	Junction Capacitance	$V_{IO}=0\text{V}$, $f=1\text{MHz}$		0.4	0.7	pF

AOZ8851ADI-24						
Symbol	Parameter	Conditions	Min.	Typ.	Max.	Units
V_{RWM}	Reverse Working Voltage				24	V
V_{BR}	Reverse Breakdown Voltage	$I_T = 1\text{mA}$	26.2	30	33	V
I_R	Reverse Leakage Current	Max. V_{RWM}		1	100	nA
V_{CL}	Clamping Voltage ^(3,4) (100ns Transmission Line Pulse)	$I_{TLP}=1\text{A}$		34	40	V
		$I_{TLP}=8\text{A}$		70	80	
	Clamping Voltage ⁽³⁾ (IEC61000-4-5 Surge 8/20 μs)	$I_{PP}=1\text{A}$		42	49	
R_{DNY}	Dynamic Resistance ^(3,4)	$I_{TLP}=1$ to 8A		5		Ω
C_J	Junction Capacitance	$V_{IO}=0\text{V}$, $f=1\text{MHz}$		0.4	0.7	pF

Notes:

3. These specifications are guaranteed by design and characterization.
4. Measurements performed using a 100ns Transmission Line Pulse (TLP) system.

Typical Performance Characteristics

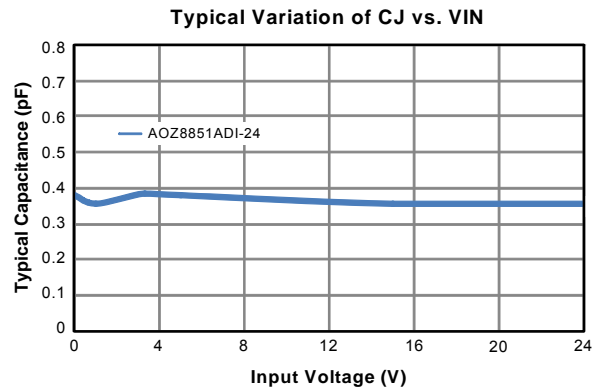
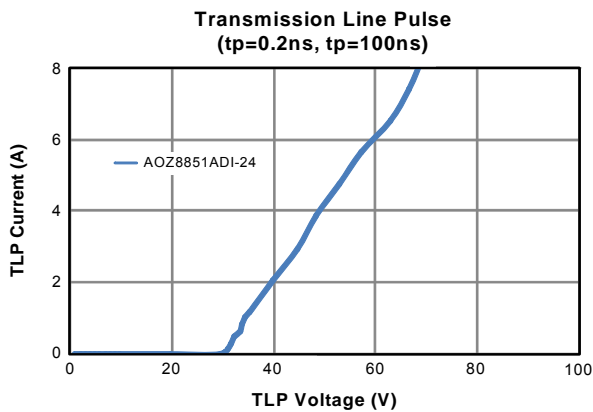
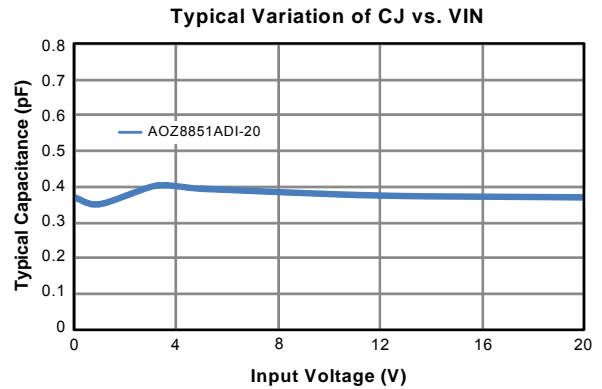
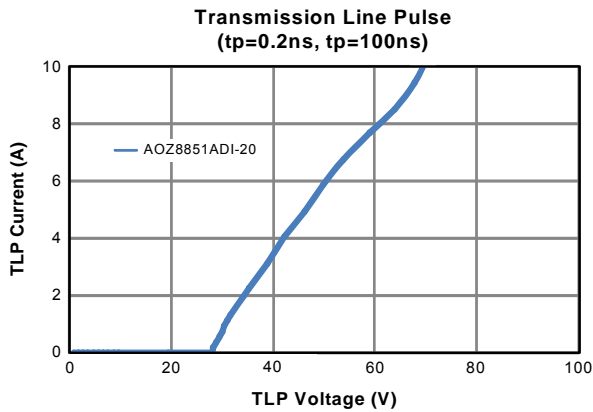
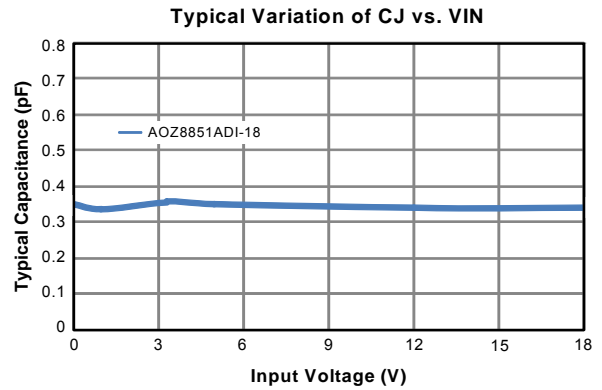
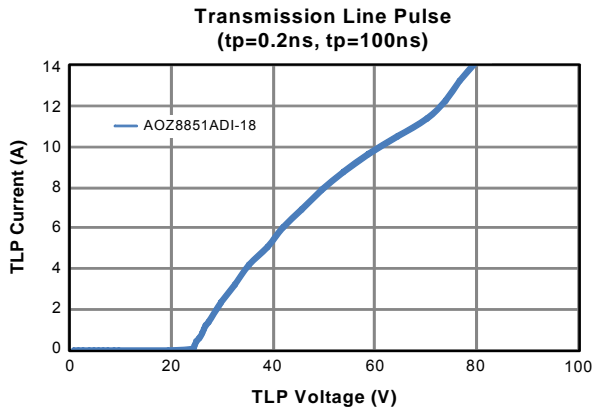

Package Dimensions, DFN 0.62x0.32, 2L

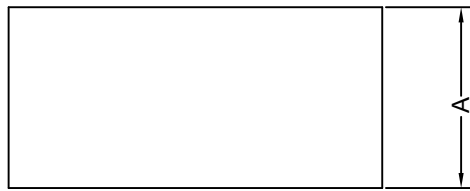
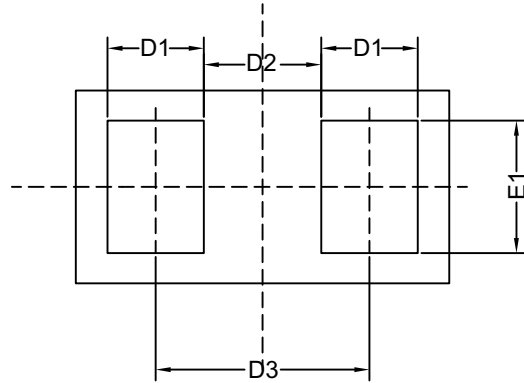
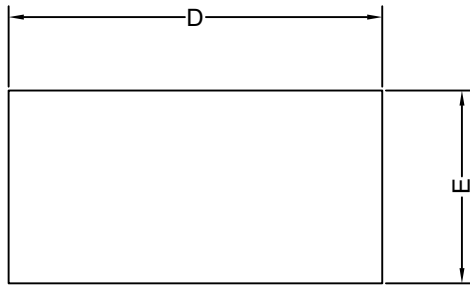

RECOMMEND LAND PATTERN

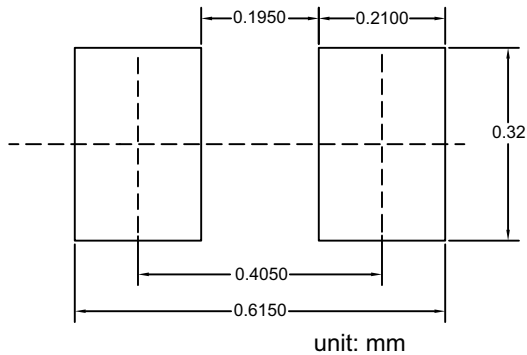

SYMBOLS	DIMENSIONS IN MILLIMETERS			DIMENSIONS IN INCHES		
	MIN	NOM	MAX	MIN	NOM	MAX
A	0.27	0.30	0.33	0.0106	0.0118	0.0130
D	0.57	0.62	0.67	0.0224	0.0244	0.0264
D1	0.11	0.16	0.21	0.0043	0.0063	0.0083
D2	0.145	0.195	0.245	0.0057	0.0077	0.0097
D3	0.305	0.355	0.405	0.0120	0.0140	0.0160
E	0.27	0.32	0.37	0.0106	0.0126	0.0146
E1	0.17	0.22	0.27	0.0067	0.0087	0.0107

NOTE

1. ALL DIMENSIONS ARE IN MILLIMETERS.
2. DIMENSIONS ARE INCLUSIVE OF PLATING.
3. PACKAGE BODY SIZES EXCLUDE MOLD FLASH AND GATE BURRS.
MOLD FLASH AT THE NON-LEAD SIDES SHOULD BE LESS THAN 6MIL EACH.
4. CONTROLLING DIMENSIONS IN MILLIMETER.
CONVERTED INCH DIMENSTIONS ARE NOT NECESSARILY EXACT.
5. PADDLE EXPOSED ON BOTTOM.

Tape and Reel Dimensions, DFN 0.62x0.32

Carrier Tape

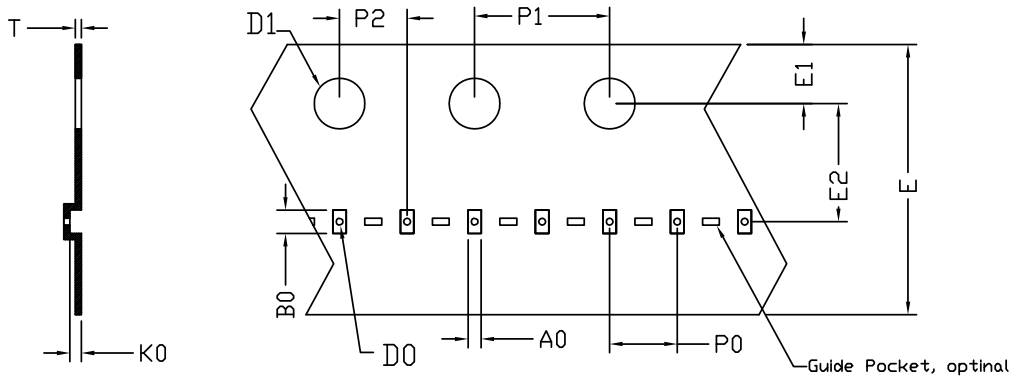

UNIT: MM

PACKAGE	A0	B0	K0	D0	D1	E	E1	E2	P0	P1	P2	T
DFN0.62x0.32 (8 mm)	0.39 ±0.03	0.69 ±0.03	0.34 +0.03 -0.01	0.20 ±0.05	1.50 +0.1 -0.0	8.00 ±0.10	1.75 ±0.10	3.50 ±0.03	2.00 ±0.05	4.00 ±0.05	2.00 ±0.05	0.20 ±0.05

Reel

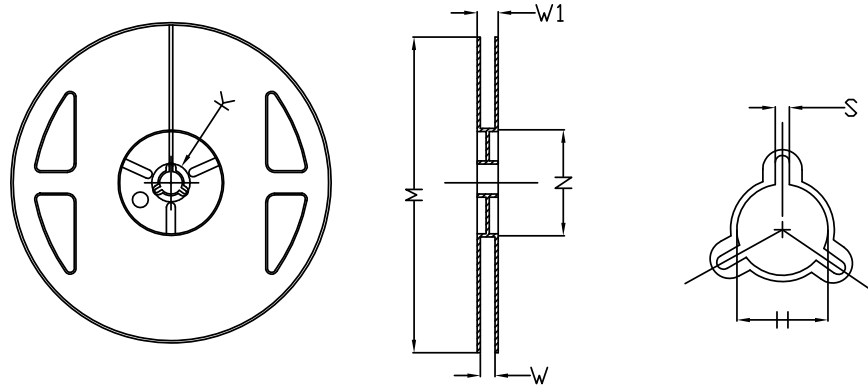

UNIT: MM

TAPE SIZE	REEL SIZE	M	N	W	W1	H	K	S
8 mm	Ø180	Ø180 +0 -3	Ø60 +1 -0	9.0 ±0.3	11.4 ±1.0	Ø13.0 ±0.2	Ø21.0 ±0.5	2.0 ±0.5

Leader / Trailer & Orientation

Unit Per Reel: 10000pcs

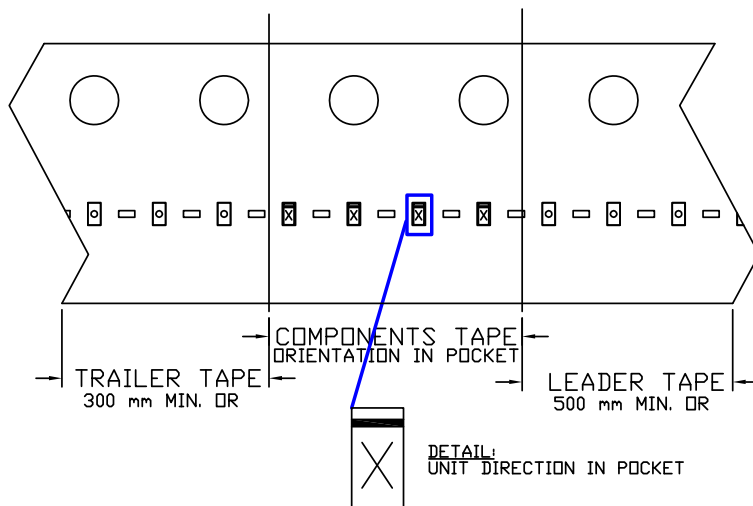

Part Marking

**AOZ8851ADI
(DFN0.62x0.32)**

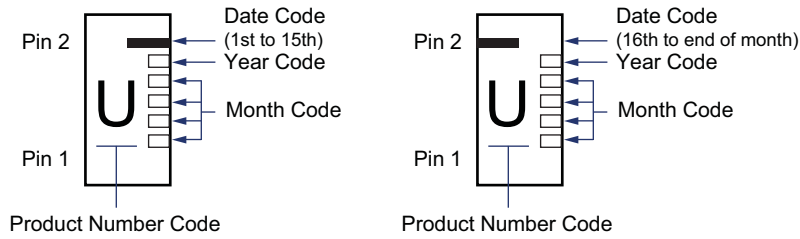

Part Number	Marking Code
AOZ8851ADI-18	U
AOZ8851ADI-20	4
AOZ8851ADI-24	V

LEGAL DISCLAIMER

Alpha and Omega Semiconductor makes no representations or warranties with respect to the accuracy or completeness of the information provided herein and takes no liabilities for the consequences of use of such information or any product described herein. Alpha and Omega Semiconductor reserves the right to make changes to such information at any time without further notice. This document does not constitute the grant of any intellectual property rights or representation of non-infringement of any third party's intellectual property rights.

LIFE SUPPORT POLICY

ALPHA AND OMEGA SEMICONDUCTOR PRODUCTS ARE NOT AUTHORIZED FOR USE AS CRITICAL COMPONENTS IN LIFE SUPPORT DEVICES OR SYSTEMS.

As used herein:

1. Life support devices or systems are devices or systems which, (a) are intended for surgical implant into the body or (b) support or sustain life, and (c) whose failure to perform when properly used in accordance with instructions for use provided in the labeling, can be reasonably expected to result in a significant injury of the user.
2. A critical component in any component of a life support, device, or system whose failure to perform can be reasonably expected to cause the failure of the life support device or system, or to affect its safety or effectiveness.

单击下面可查看定价，库存，交付和生命周期等信息

[>>AOS\(万国半导体\)](#)