

General Description

The AOZ8906ACI is a 4-channel transient voltage suppressor array designed to protect high speed data lines such as USB2.0 in notebook and computer from damaging ESD events.

This device incorporates eight surge rated, low capacitance steering diodes and a TVS in a single package. During transient conditions, the steering diodes direct the transient to either the positive side of the power supply line or to ground.

The AOZ8906ACI comes in a RoHS compliant and Halogen Free SOT23-6L package and is rated for -40°C to +125°C junction temperature range.

Features

- ESD protection for high-speed data lines:
 - IEC 61000-4-2, level 4 (ESD) immunity test
 - Air discharge: ±30kV
 - Contact discharge: ±30kV
 - IEC61000-4-5 (Lightning) 10A (8/20µs)
 - Human Body Model (HBM) ±8kV
- Protects four I/O lines
- Low capacitance between I/O to GND: 1.8 pF
- Low clamping voltage
- Low operating voltage: 5.0 V

Applications

- USB2.0
- SD and SIM cards
- Monitors and flat panel displays
- Set-top box
- Notebook computers



Typical Application

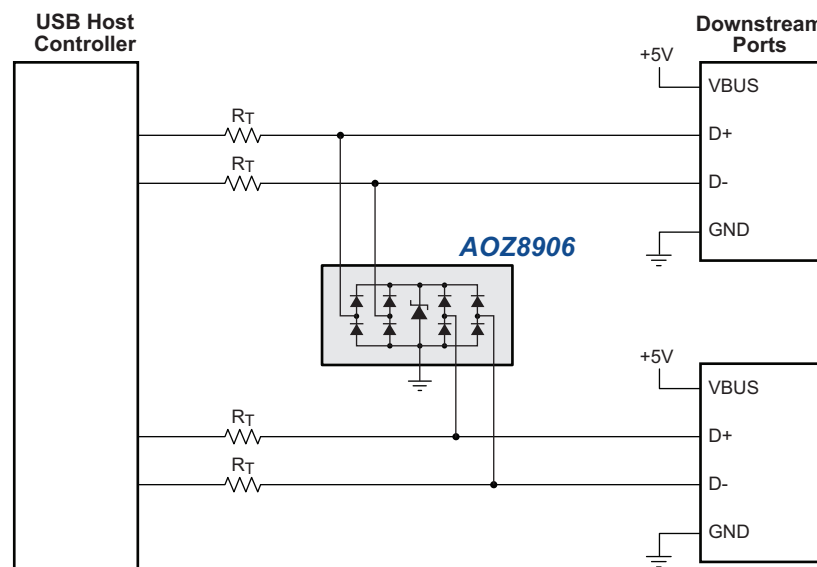

Figure 1. USB High Speed Ports

Ordering Information

Part Number	Ambient Temperature Range	Package	Environmental
AOZ8906ACI	-40°C to +125°C	SOT23-6L	Green Product



AOS Green Products use reduced levels of Halogens, and are also RoHS compliant. Please visit www.aosmd.com/media/AOSGreenPolicy.pdf for additional information.

Pin Configuration

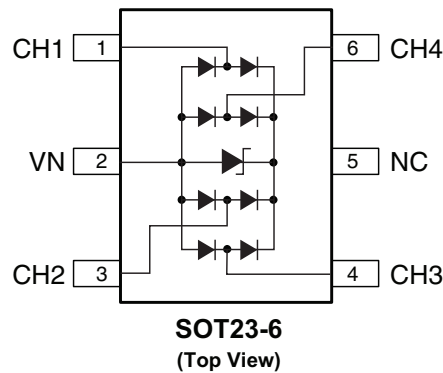

Absolute Maximum Ratings

Exceeding the Absolute Maximum ratings may damage the device.

Parameter	Rating
Storage Temperature (T_S)	-65°C to +150°C
ESD Rating per IEC61000-4-2, contact ⁽¹⁾	±30kV
ESD Rating per IEC61000-4-2, air ⁽¹⁾	±30kV
8/20µs Surge IEC61000-4-5	±10 A
ESD Rating per Human Body Model ⁽²⁾	±8kV

Notes:

- IEC 61000-4-2 discharge with $C_{Discharge} = 150\text{pF}$, $R_{Discharge} = 330\Omega$.
- Human Body Discharge per MIL-STD-883, Method 3015 $C_{Discharge} = 100\text{pF}$, $R_{Discharge} = 1.5\text{k}\Omega$.

Maximum Operating Ratings

Parameter	Rating
Junction Temperature (T_J)	-40°C to +125°C

Electrical Characteristics

T_A = 25°C unless otherwise specified. Any I/O Pin to GND.

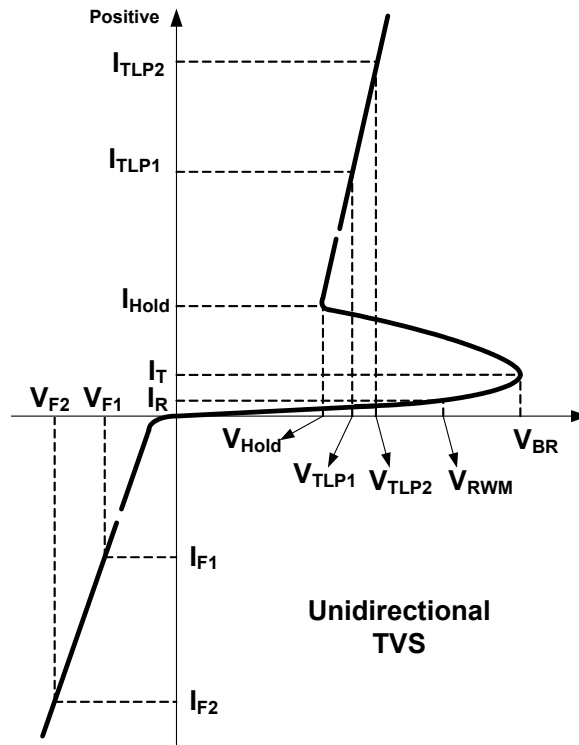

Symbol	Parameter	Conditions	Min.	Typ.	Max.	Units
V _{RWM}	Reverse Working Voltage				5	V
V _{BR}	Reverse Breakdown Voltage	I _T = 100µA	6	8.5	11	V
I _R	Reverse Leakage Current	V _T = Max, V _{RWM}		1	50	nA
V _F	Diode Forward Voltage	I _F = 15mA		0.85		V
V _{HOLD}	Hold Voltage of Snapback ⁽³⁾		0.9			V
I _{HOLD}	Hold Current of Snapback ⁽³⁾		12			mA
V _{CL}	Clamping Voltage ⁽³⁾⁽⁴⁾ (100ns Transmission Line Pulse)	I _{PP} = 1A I _{PP} = -1A		1.5 -1	2.5 -2	V
		I _{PP} = 16A I _{PP} = -16A		3.5 -3.3	4.5 -4.3	
R _{DYN}	Dynamic Resistance	I _{TLP} = 8A to 16A I _{TLP} = -8A to -16A		0.12 0.12		Ω
V _{CL}	Clamping Voltage ⁽³⁾ IEC61000-4-5 Surge 8/20µs	I _{PP} = 1A I _{PP} = -1A		1.3 -1.2	1.8 -1.7	V
		I _{PP} = 10A I _{PP} = -10A		3.9 -2.4	5 -3	
C _j	Junction Capacitance	V _{I/O} = 0V, f = 1MHz, Any I/O pin to Ground		1.8	2.2	pF

Notes:

- 3. These specifications are guaranteed by design and characterization.
- 4. Measurements performed using a 100ns Transmission Line Pulse (TLP) system.

Typical Performance Characteristics

Typical Variations of CJ vs. Input Voltage

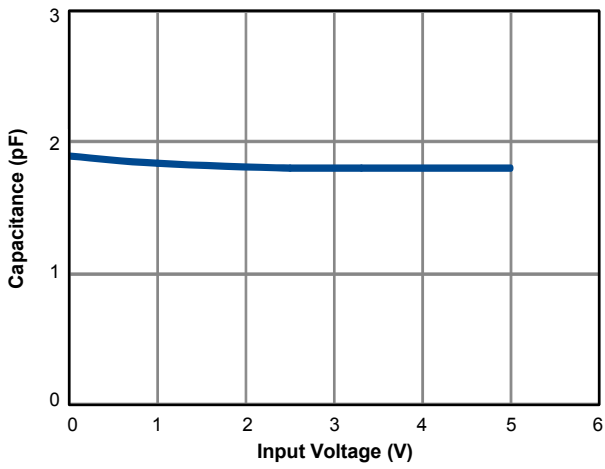

IEC61000-4-5 Surge 8.20μs

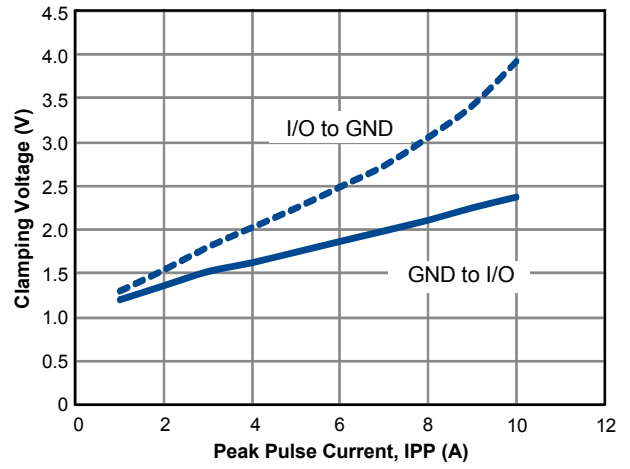

Positive Transmission Line Pulse
(tp=100ns, tr=0.2ns)

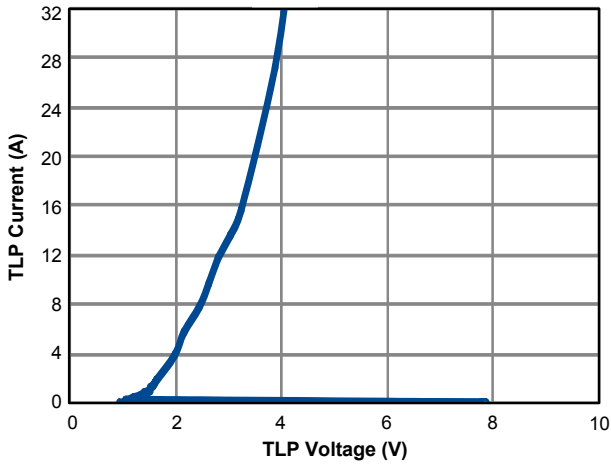

Negative Transmission Line Pulse
(tp=100ns, tr=0.2ns)

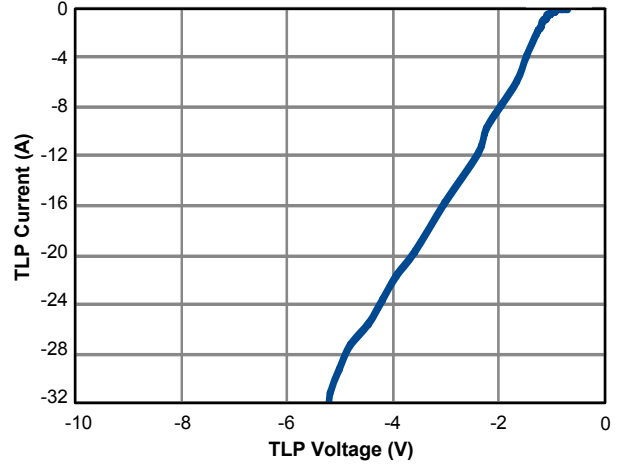

Tape and Reel Dimensions, SOT23-6L

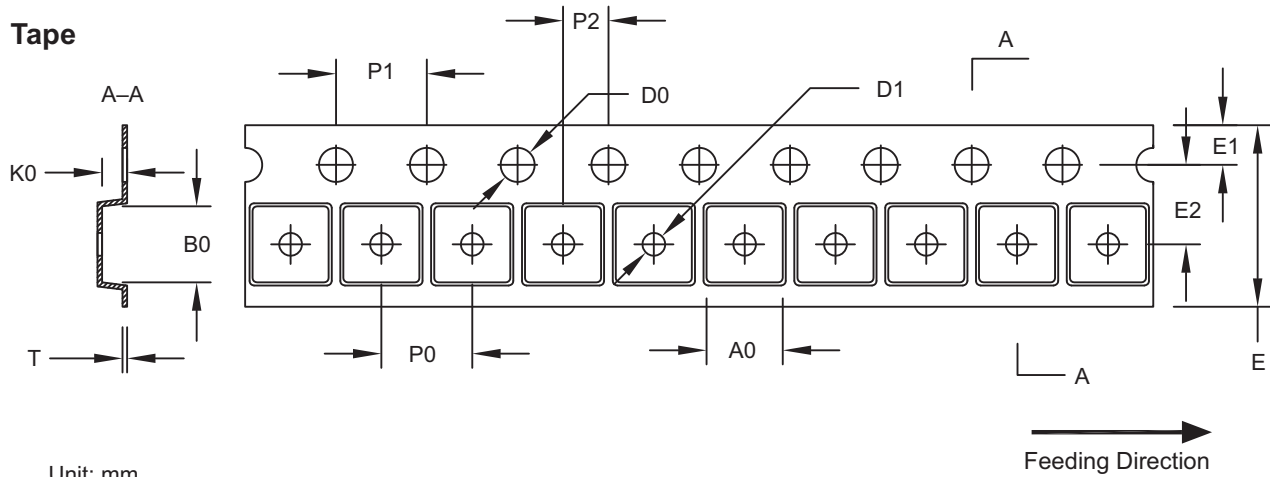

Unit: mm

Package	A0	B0	K0	D0	D1	E	E1	E2	P0	P1	P2	T
SOT-23	3.15 ±0.10	3.20 ±0.10	1.40 ±0.10	1.50 ±0.05	1.00 ±0.10/-0.0	8.00 ±0.30	1.75 ±0.10	3.50 ±0.05	4.00 ±0.10	4.00 ±0.10	2.00 ±0.05	0.23 ±0.03

Reel

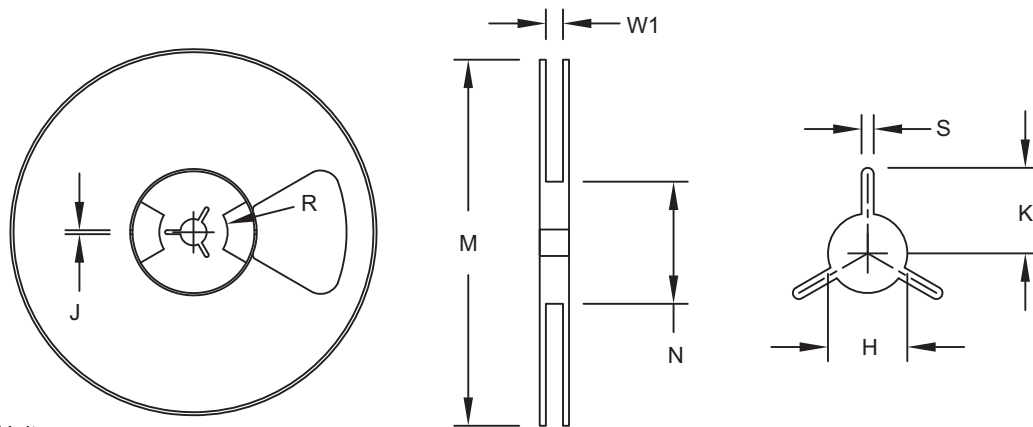

Unit: mm

Tape Size	Reel Size	M	N	W1	H	S	K	R	J
8 mm	ø177.80	ø177.80 MAX.	ø55.00 MIN.	8.40 +1.50/-0.00	ø13.00 +0.50 / -0.20	1.50 MIN.	10.10 MIN.	12.70	4.00 +0.10/-0.10

Leader/Trailer and Orientation

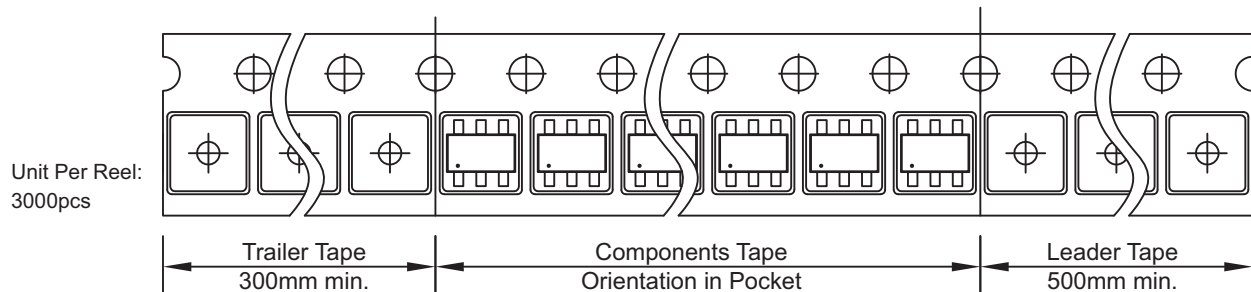

Package Dimensions, SOT23-6L

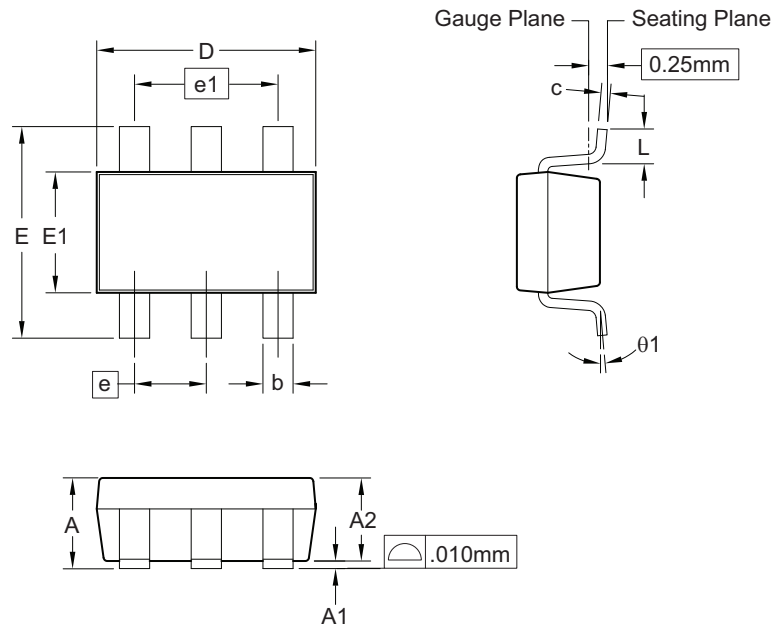

RECOMMENDED LAND PATTERN

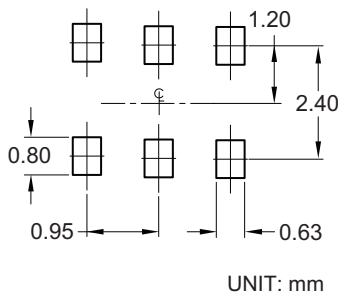

Dimensions in millimeters

Symbols	Min.	Nom.	Max.
A	0.90	—	1.25
A1	0.00	—	0.15
A2	0.70	1.10	1.20
b	0.30	0.40	0.50
c	0.08	0.13	0.20
D	2.70	2.90	3.10
E	2.50	2.80	3.10
E1	1.50	1.60	1.70
e	0.95 BSC		
e1	1.90 BSC		
L	0.30	—	0.60
θ1	0°	—	8°

Dimensions in inches

Symbols	Min.	Nom.	Max.
A	0.035	—	0.049
A1	0.00	—	0.006
A2	0.028	0.043	0.047
b	0.012	0.016	0.020
c	0.003	0.005	0.008
D	0.106	0.114	0.122
E	0.098	0.110	0.122
E1	0.059	0.063	0.067
e	0.037 BSC		
e1	0.075 BSC		
L	0.012	—	0.024
θ1	0°	—	8°

Notes:

1. Package body sizes exclude mold flash and gate burrs. Mold flash at the non-lead sides should be less than 5 mils each.
2. Dimension "L" is measured in gauge plane.
3. Tolerance ±0.100 mm (4 mil) unless otherwise specified.
4. Followed from JEDEC MO-178C & MO-193C.
5. Controlling dimension is millimeter. Converted inch dimensions are not necessarily exact.

Package Marking

**AOZ8906ACI
(SOT23_6L)**

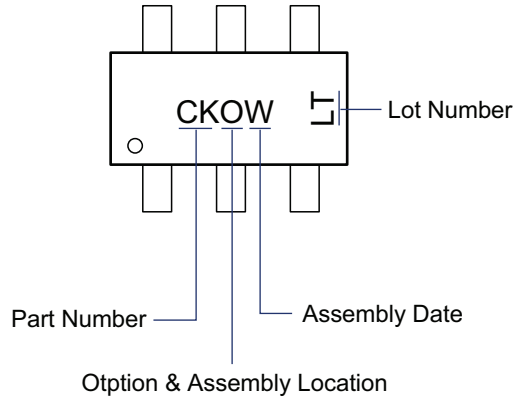

LEGAL DISCLAIMER

Alpha and Omega Semiconductor makes no representations or warranties with respect to the accuracy or completeness of the information provided herein and takes no liabilities for the consequences of use of such information or any product described herein. Alpha and Omega Semiconductor reserves the right to make changes to such information at any time without further notice. This document does not constitute the grant of any intellectual property rights or representation of non-infringement of any third party’s intellectual property rights.

LIFE SUPPORT POLICY

ALPHA AND OMEGA SEMICONDUCTOR PRODUCTS ARE NOT AUTHORIZED FOR USE AS CRITICAL COMPONENTS IN LIFE SUPPORT DEVICES OR SYSTEMS.

As used herein:

- | | |
|---|---|
| <p>1. Life support devices or systems are devices or systems which, (a) are intended for surgical implant into the body or (b) support or sustain life, and (c) whose failure to perform when properly used in accordance with instructions for use provided in the labeling, can be reasonably expected to result in a significant injury of the user.</p> | <p>2. A critical component in any component of a life support, device, or system whose failure to perform can be reasonably expected to cause the failure of the life support device or system, or to affect its safety or effectiveness.</p> |
|---|---|

单击下面可查看定价，库存，交付和生命周期等信息

[>>AOS\(万国半导体\)](#)