

General Description

The AOZ8934 is a transient voltage suppressor array designed to protect high speed data lines. It is specially designed to protect portable devices that utilize the USB port for battery charging.

This device incorporates three surge rated, low capacitance steering diodes and a TVS in a single package. During transient conditions, the steering diodes direct the transient to either the positive side of the power supply line or to ground. It provides a typical line-to-line capacitance of 0.3 pF and low insertion loss up to 6 GHz providing greater signal integrity making it ideally suited for USB 2.0 applications. An integrated 26V TVS diode is used for protection of the USB voltage bus.

The AOZ8934 comes in a RoHS compliant SOT23-6 package and is rated for -40 °C to +125 °C junction temperature range.

Features

- Array of surge rated diodes with internal TVS diode
- ESD protection for high-speed data lines:
 - IEC 61000-4-2, level 4 (ESD) immunity test
Air discharge: ± 20 kV; contact discharge: ± 15 kV
 - IEC61000-4-4 (EFT) 40 A (5/50 ns)
 - IEC61000-4-5 (Lightning) 4 A (8/20 μ s)
 - Human Body Model (HBM) ± 24 kV
- Low capacitance between I/O lines
- Low clamping voltage on D+, D- and ID pins
- Protects USB VBus operating up to 26 V
 - IEC61000-4-2, level 4 (ESD) immunity test
Air discharge: ± 30 kV; contact discharge: ± 30 kV
 - IEC61000-4-5 (Lightning) 30 A (8/20 μ s)
- Small package saves board space

Applications

- USB 2.0
- USB OTG



Typical Application

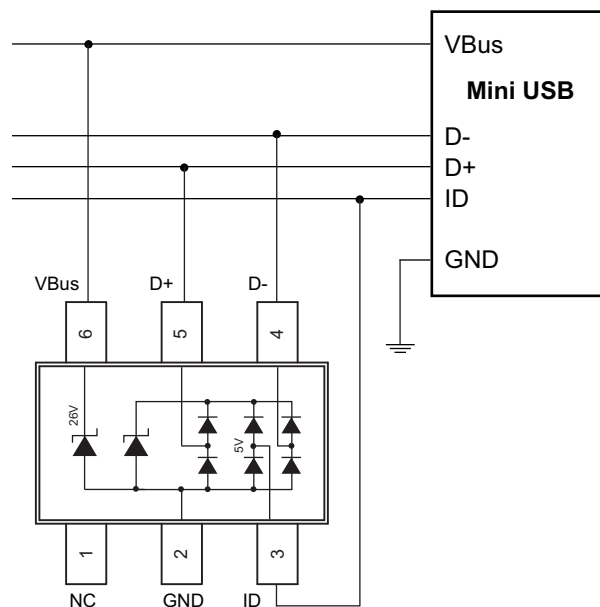

AOZ8934CI-26

Ordering Information

Part Number	Ambient Temperature Range	Package	Environmental
AOZ8934CI-26	-40 °C to +85 °C	SOT23-6	RoHS Compliant Green Product



AOS Green Products use reduced levels of Halogens, and are also RoHS compliant. Please visit www.aosmd.com/media/AOSGreenPolicy.pdf for additional information.

Pin Configuration

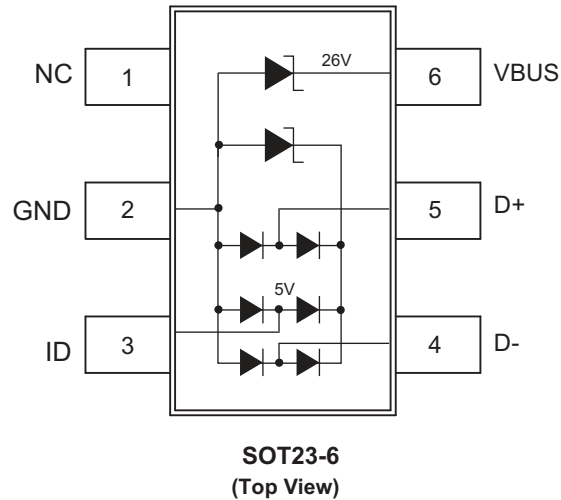

Absolute Maximum Ratings

Exceeding the Absolute Maximum ratings may damage the device.

Parameter	
Storage Temperature (T_S)	-65 °C to +150 °C
ESD Rating per IEC61000-4-2, contact ⁽¹⁾	±15 kV
ESD Rating per IEC61000-4-2, air ⁽¹⁾	±20 kV
ESD Rating per Human Body Model ⁽²⁾	±24 kV

Notes:

- IEC 61000-4-2 discharge with $C_{Discharge} = 150\text{pF}$, $R_{Discharge} = 330\ \Omega$.
- Human Body Discharge per MIL-STD-883, Method 3015 $C_{Discharge} = 100\ \text{pF}$, $R_{Discharge} = 1.5\ \text{k}\Omega$.

Maximum Operating Ratings

Parameter	Rating
Junction Temperature (T_J)	-40 °C to +125 °C

Electrical Characteristics

$T_A = 25^\circ\text{C}$ unless otherwise specified.

Symbol	Parameter	Diagram
I_{PP}	Maximum Reverse Peak Pulse Current	
V_{CL}	Clamping Voltage @ I_{PP}	
V_{RWM}	Working Peak Reverse Voltage	
I_R	Maximum Reverse Leakage Current	
V_{BR}	Breakdown Voltage	
I_T	Test Current	
V_F	Forward Voltage @ I_F	
P_{pk}	Peak Power Dissipation (IEC61000-4-5 8/20 μs pulse)	
C_J	Max. Capacitance @ $V_R = 0$ and $f = 1$ MHz	

Pin	V_{RWM} (V) Max.	V_{BR} (V) Min. $I_T = 100 \mu\text{A}$	I_R (μA) Max.	V_F (V) Typ.	V_{CL} @ I_{PP} 8/20 μs ⁽³⁾		P_{pk} (W)	C_J (pF)	
					I_{PP} (A)	V_{CL} (V)		Typ.	Max.
D+, D-, ID	5	6	1.0	0.85	4	7	30	0.6	0.75
VBUS	26	29	1.0	0.85	30	50	1500	200	250

Notes:

3. These specifications are guaranteed by design and characterization.

Typical Performance Characteristics for D+, D- and ID

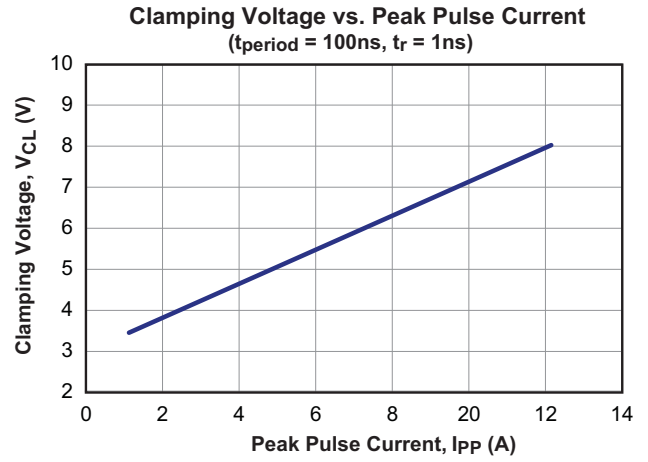
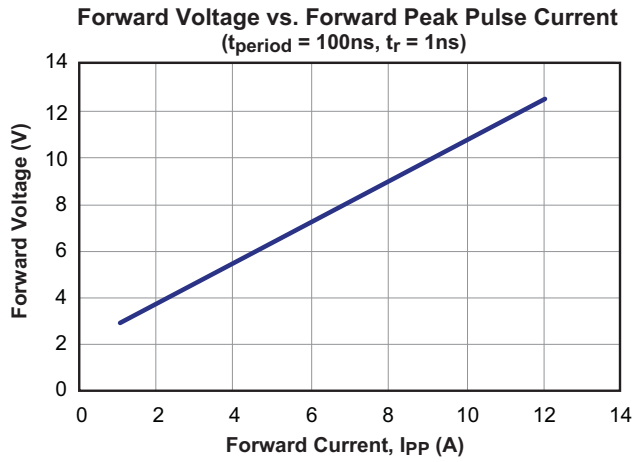

Typical Performance Characteristics for VBUS

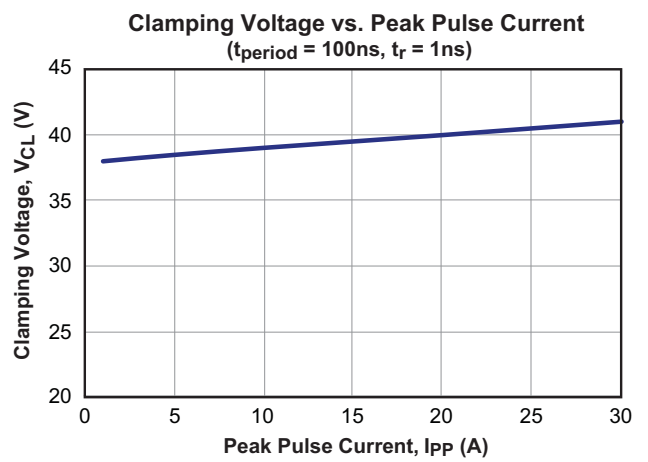
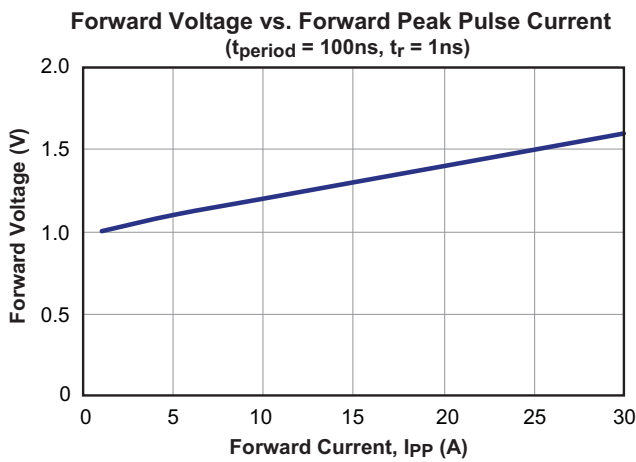

Package Dimensions, SOT23, 6L

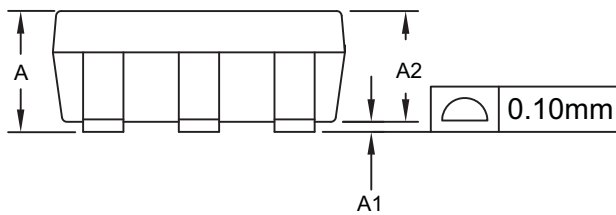
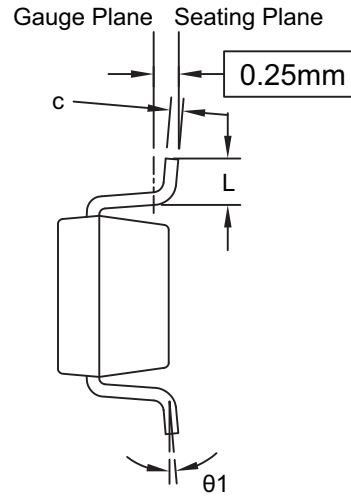
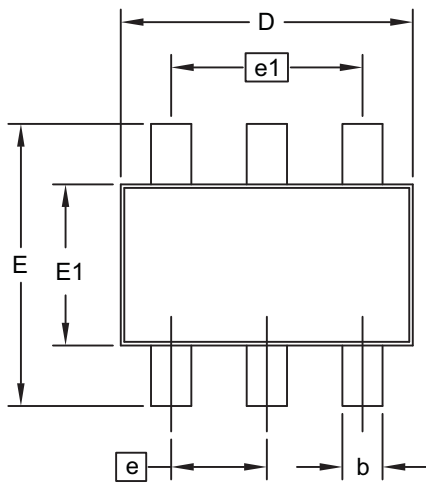

RECOMMENDED LAND PATTERN

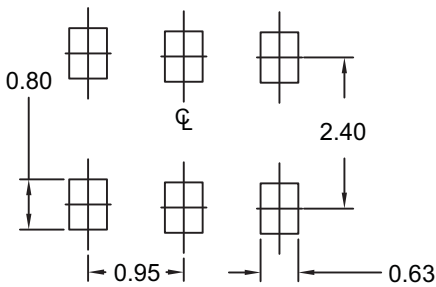

UNIT: mm

Dimensions in millimeters

Symbols	Min.	Nom.	Max.
A	0.80	---	1.25
A1	0.00	---	0.15
A2	0.70	1.10	1.20
b	0.30	0.40	0.50
c	0.08	0.13	0.20
D	2.70	2.90	3.10
E	2.50	2.80	3.10
E1	1.50	1.60	1.70
e	0.95 BSC		
e1	1.90 BSC		
L	0.30	---	0.60
θ_1	0°	---	8°

Dimensions in inches

Symbols	Min.	Nom.	Max.
A	0.035	---	0.049
A1	0.000	---	0.006
A2	0.031	0.043	0.047
b	0.012	0.016	0.020
c	0.003	0.005	0.008
D	0.106	0.114	0.122
E	0.098	0.110	0.122
E1	0.059	0.063	0.067
e	0.037 BSC		
e1	0.075 BSC		
L	0.012	---	0.024
θ_1	0°	---	8°

Note:

1. Package body sizes exclude mold flash and gate burrs. Mold flash at the non-lead sides should be less than 5mils each.
2. Dimension "L" is measured in gauge plane.
3. Tolerance $\pm 0.100\text{mm}$ (4 mil) unless otherwise specified.
4. Followed from JEDEC MO-178C & MO-193C.
5. Controlling dimension is millimeter. Converted inch dimensions are not necessarily exact.

Tape and Reel Dimensions, SOT23, 6L

Carrier Tape

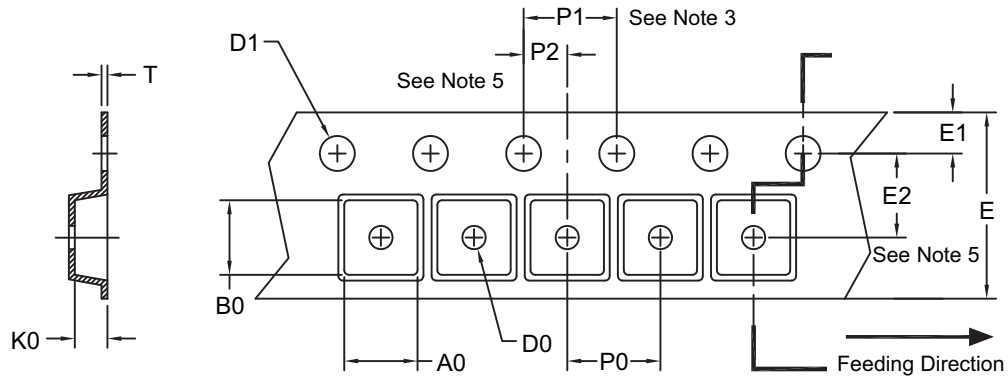

UNIT: mm

Package	A0	B0	K0	D0	D1	E	E1	E2	P0	P1	P2	T
SOT-23 (8 mm)	3.15 ±0.10	3.27 ±0.10	1.34 ±0.10	1.10 ±0.01	1.50 ±0.10	8.00 ±0.20	1.75 ±0.10	3.50 ±0.05	4.00 ±0.10	4.00 ±0.10	2.00 ±0.05	0.25 ±0.05

Reel

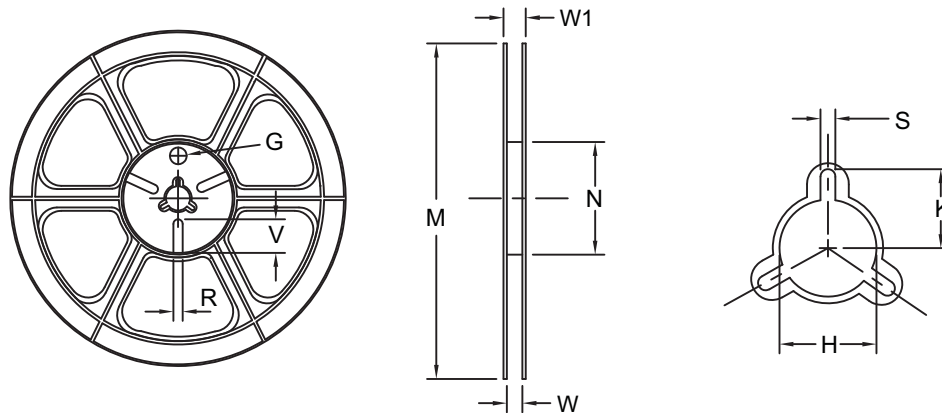

UNIT: mm

Tape Size	Reel Size	M	N	W	W1	H	K	S	G	R	V
8mm	ø180	ø180.00 ±0.50	ø60.50 ±0.50	9.00 ±0.30	11.40 ±1.00	ø13.00 +0.50/-0.20	10.60	2.00 ±0.50	ø9.00	5.00	18.00

Leader/Trailer & Orientation

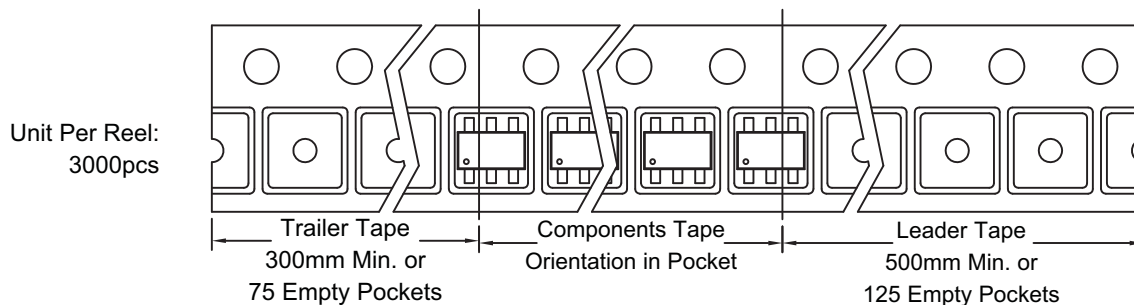

Part Marking

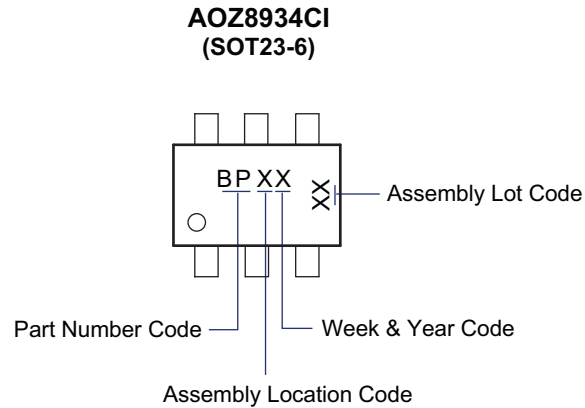

LEGAL DISCLAIMER

Alpha and Omega Semiconductor makes no representations or warranties with respect to the accuracy or completeness of the information provided herein and takes no liabilities for the consequences of use of such information or any product described herein. Alpha and Omega Semiconductor reserves the right to make changes to such information at any time without further notice. This document does not constitute the grant of any intellectual property rights or representation of non-infringement of any third party's intellectual property rights.

LIFE SUPPORT POLICY

ALPHA AND OMEGA SEMICONDUCTOR PRODUCTS ARE NOT AUTHORIZED FOR USE AS CRITICAL COMPONENTS IN LIFE SUPPORT DEVICES OR SYSTEMS.

As used herein:

1. Life support devices or systems are devices or systems which, (a) are intended for surgical implant into the body or (b) support or sustain life, and (c) whose failure to perform when properly used in accordance with instructions for use provided in the labeling, can be reasonably expected to result in a significant injury of the user.
2. A critical component in any component of a life support, device, or system whose failure to perform can be reasonably expected to cause the failure of the life support device or system, or to affect its safety or effectiveness.

单击下面可查看定价，库存，交付和生命周期等信息

[>>AOS\(万代\)](#)