

Description

The ASDXXCL is designed to replace multilayer varistors (MLVs) in portable applications such as cell phones, notebook computers and PDA's, using monolithic silicon technology to provide fast response time and ultra low ESD clamping voltage, making this device an ideal solution for protecting sensitive semiconductor components from damage. The ASDXXCL complies with the IEC 61000-4-2 (ESD) with $\pm 30\text{kV}$ air and $\pm 30\text{kV}$ contact discharge. The ASDXXCL is assembled into a lead-free SOD-323 package and will protect one bidirectional line.

Features

- 300W peak pulse power (8/20 μs)
- Protects one data or power line
- Ultra low leakage: nA level
- Operating voltage: 3.3V, 5V, 12V, 24V, 36V
- Ultra low clamping voltage
- Complies with following standards:
 - IEC 61000-4-2 (ESD) immunity test
 - Air discharge: $\pm 30\text{kV}$
 - Contact discharge: $\pm 30\text{kV}$
- RoHS Compliant

Mechanical Characteristics

- Package: SOD-323
- Lead Finish: Matte Tin
- Case Material: "Green" Molding Compound.
- Moisture Sensitivity: Level 3 per J-STD-020
- Terminal Connections: See Diagram Below
- Marking Information: See Below

Applications

- Cellular Handsets and Accessories
- Personal Digital Assistants
- Notebooks and Handhelds
- Portable Instrumentation
- Peripherals
- Pagers Peripherals
- Desktop and Servers

Marking Information

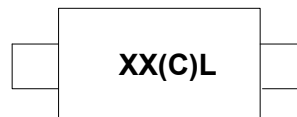

Part Number	Marking
ASD33CL	33L
ASD05CL	05CL
ASD08CL	08L
ASD12CL	12L
ASD24CL	24L
ASD36CL	36L

Dimensions and Pin Configuration

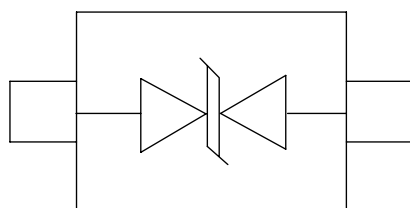

SOD-323

Ordering Information

Part Number	Packaging	Reel Size
ASD33CL	3000/Tape & Reel	7 inch
ASD05CL	3000/Tape & Reel	7 inch
ASD12CL	3000/Tape & Reel	7 inch
ASD24CL	3000/Tape & Reel	7 inch
ASD36CL	3000/Tape & Reel	7 inch

Absolute Maximum Ratings ($T_A=25^{\circ}\text{C}$ unless otherwise specified)

Parameter	Symbol	Value	Unit
Peak Pulse Power (8/20 μs)	Ppk	300	W
ESD per IEC 61000-4-2 (Air)	VESD	± 30	kV
ESD per IEC 61000-4-2 (Contact)		± 30	
Operating Temperature Range	TJ	-55 to +125	$^{\circ}\text{C}$
Storage Temperature Range	Tstg	-55 to +150	$^{\circ}\text{C}$

Electrical Characteristics ($T_A=25^{\circ}\text{C}$ unless otherwise specified)

ASD33CL						
Parameter	Symbol	Min	Typ	Max	Unit	Test Condition
Reverse Working Voltage	VRWM			3.3	V	
Breakdown Voltage	VBR	3.8			V	IT = 1mA
Reverse Leakage Current	IR			1.0	μA	VRWM = 3.3V
Clamping Voltage	VC			6	V	I _{PP} = 1A (8 x 20 μs pulse)
Clamping Voltage	VC			12	V	I _{PP} = 25A (8 x 20 μs pulse)
Peak Pulse Current	I _{PP}			25	A	t _p = 8/20 μs
Junction Capacitance	CJ			100	pF	VR = 0V, f = 1MHz, Pin 1 to Pin 3 or Pin 2 to Pin 3

ASD05CL						
Parameter	Symbol	Min	Typ	Max	Unit	Test Condition
Reverse Working Voltage	VRWM			5	V	
Breakdown Voltage	VBR	6			V	IT = 1mA
Reverse Leakage Current	IR			1.0	μA	VRWM = 5V
Clamping Voltage	VC			8	V	I _{PP} = 1A (8 x 20 μs pulse)
Clamping Voltage	VC			15	V	I _{PP} = 20A (8 x 20 μs pulse)
Peak Pulse Current	I _{PP}			20	A	t _p = 8/20 μs
Junction Capacitance	CJ			80	pF	VR = 0V, f = 1MHz, Pin 1 to Pin 3 or Pin 2 to Pin 3

ASD08CL						
Parameter	Symbol	Min	Typ	Max	Unit	Test Condition
Reverse Working Voltage	VRWM			8	V	
Breakdown Voltage	VBR	8.5			V	IT = 1mA
Reverse Leakage Current	IR			0.5	μA	VRWM = 8V
Clamping Voltage	VC			13	V	I _{PP} = 1A (8 x 20μs pulse)
Clamping Voltage	VC			17	V	I _{PP} = 18A (8 x 20μs pulse)
Peak Pulse Current	I _{PP}			18	A	t _p = 8/20μs
Junction Capacitance	C _J			60	pF	VR = 0V, f = 1MHz, Pin 1 to Pin 3 or Pin 2 to Pin 3

ASD12CL						
Parameter	Symbol	Min	Typ	Max	Unit	Test Condition
Reverse Working Voltage	VRWM			12	V	
Breakdown Voltage	VBR	13.3			V	IT = 1mA
Reverse Leakage Current	IR			0.5	μA	VRWM = 12V
Clamping Voltage	VC			18	V	I _{PP} = 1A (8 x 20μs pulse)
Clamping Voltage	VC			25	V	I _{PP} = 12A (8 x 20μs pulse)
Peak Pulse Current	I _{PP}			12	A	t _p = 8/20μs
Junction Capacitance	C _J		32		pF	VR = 0V, f = 1MHz, Pin 1 to Pin 3 or Pin 2 to Pin 3

ASD24CL						
Parameter	Symbol	Min	Typ	Max	Unit	Test Condition
Reverse Working Voltage	VRWM			24	V	
Breakdown Voltage	VBR	27			V	IT = 1mA
Reverse Leakage Current	IR			0.2	μA	VRWM = 24V
Clamping Voltage	VC			40	V	I _{PP} = 1A (8 x 20μs pulse)
Clamping Voltage	VC			60	V	I _{PP} = 5A (8 x 20μs pulse)
Peak Pulse Current	I _{PP}			5	A	t _p = 8/20μs
Junction Capacitance	C _J		15		pF	VR = 0V, f = 1MHz, Pin 1 to Pin 3 or Pin 2 to Pin 3

ASD36CL						
Parameter	Symbol	Min	Typ	Max	Unit	Test Condition
Reverse Working Voltage	VRWM			36	V	
Breakdown Voltage	VBR	38			V	IT = 1mA
Reverse Leakage Current	IR			0.2	μA	VRWM = 36V
Clamping Voltage	VC			50	V	I _{PP} = 1A (8 x 20μs pulse)
Clamping Voltage	VC			75	V	I _{PP} = 4A (8 x 20μs pulse)
Peak Pulse Current	I _{PP}			4	A	t _p = 8/20μs
Junction Capacitance	C _J		12		pF	VR = 0V, f = 1MHz, Pin 1 to Pin 3 or Pin 2 to Pin 3

Typical Performance Characteristics ($T_A=25^{\circ}\text{C}$ unless otherwise Specified)

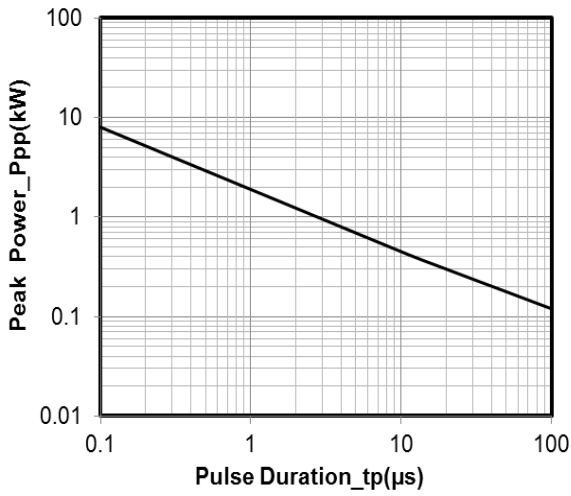

Peak Pulse Power vs. Pulse Time

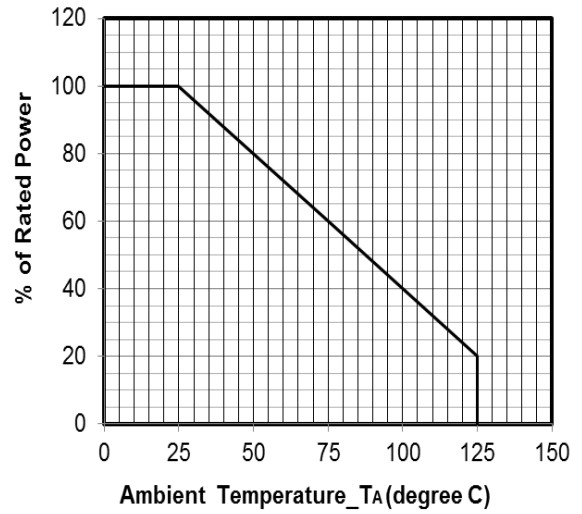

Power Derating Curve

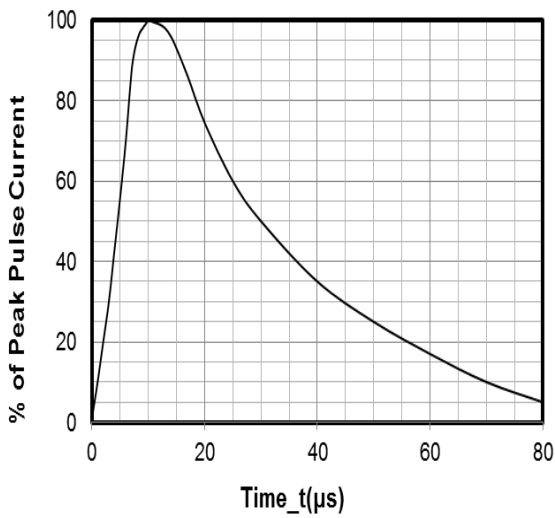

8 X 20μs Pulse Waveform

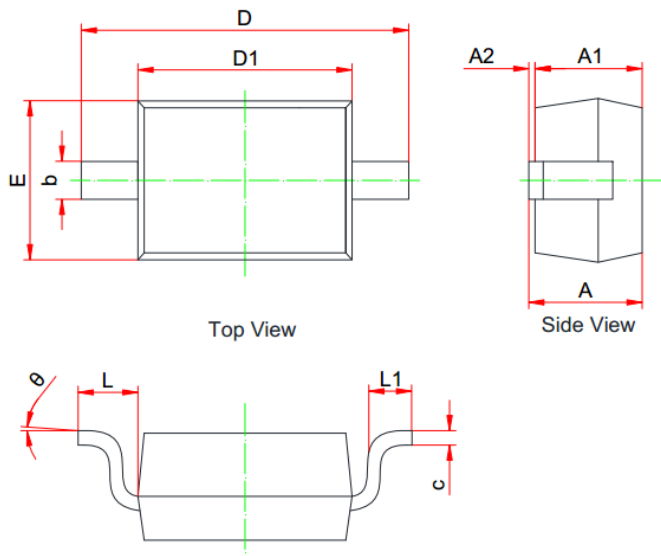
SOD-323 Package Outline Drawing

SYM	MILLIMETERS		
	MIN	NOM	MAX
A	0.800	--	1.100
A1	0.800	--	0.900
A2	0.000	--	0.100
b	0.250	--	0.400
c	0.080	--	0.177
D1	1.600	1.700	1.800
D	2.300	--	2.800
E	1.150	--	1.400
L	0.475REF		
L1	0.100	--	0.500
Θ	0°	--	8°

Suggested Land Pattern

Unit: mm
Contact Information

Applied Power Microelectronics Co., Ltd.

 Website: <http://www.appliedpowermicro.com>

 Email: sales@appliedpowermicro.com

Phone: +86 (0519) 8399 3606

单击下面可查看定价，库存，交付和生命周期等信息

[>>APPLIED POWER\(江苏应能\)](#)