

Dual Row Stacker: BTB

00-9158

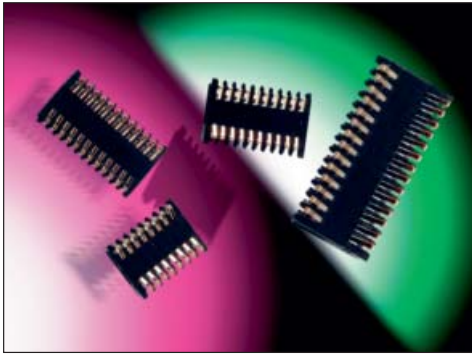

The MOBO® series 9158 is a one-piece connector used to connect two PCBs within mobile phones, pagers, PDAs, security, handheld scanners, etc. in a cost-effective manner.

A standard range is available with 16, 20, 24 and 28 contacts to suit stack heights of 1.90mm to 3.30mm. Other contact variants are also available up to 5.10mm, in custom housings. The SOLO STACKER can allow a spacing tolerance of up to ± 0.30 mm and still provide reliable connections between the PCBs, even if they are not parallel.

SOLO STACKER is designed for PCB surface mounting and is supplied in tape and reel packaging. Gold plated pads on the mating PCB or suitable flex circuits provide connection between the boards.

Whatever your requirements this SOLO STACKER can also be customized to suit your applications.

APPLICATIONS

- Mobile Phones
- PDA
- Medical
- PMR
- Industrial
- Security
- Handheld Scanner

FEATURES AND BENEFITS

- Reduced assembly time.
- Only one part to purchase and stock.
- Due to the unique contact design, the mating device does not have to be parallel.
- Extremely robust when subjected to shock and vibration.
- Cost effective.
- Helps reduce tolerance accumulation within system.

ELECTRICAL

- Current Rating: 1 Amp/Contact
- Voltage Rating: 125V
Based on placement distance

ENVIRONMENTAL

- Operating Temperature:
-55°C to +125°C

MECHANICAL

- Insulator Material: High Temperature Plastic; UL94 HB
- Contact Material: Beryllium Copper
- Plating: Gold over Nickel
- Durability: 50 Cycles

HOW TO ORDER

00	9158	0XX	0XX	06	X
Prefix	Series	Number of Ways	Stack Height	Plating Variation	PCB Location Bosses
		016 = 16 020 = 20 024 = 24 028 = 28	020 = 1.9mm to 2.1mm 025 = 2.1mm to 2.7mm 030 = 2.8mm to 3.3mm	06 = Selective Gold 0.25 μ m Gold Plated Contact Nose Pure Tin Tail	1 = With PCB Location Bosses 2 = Without PCB Location Bosses



Dual Row Stacker: BTB

00-9158

2.0MM DUAL ROW STACKER WITHOUT BOSSES

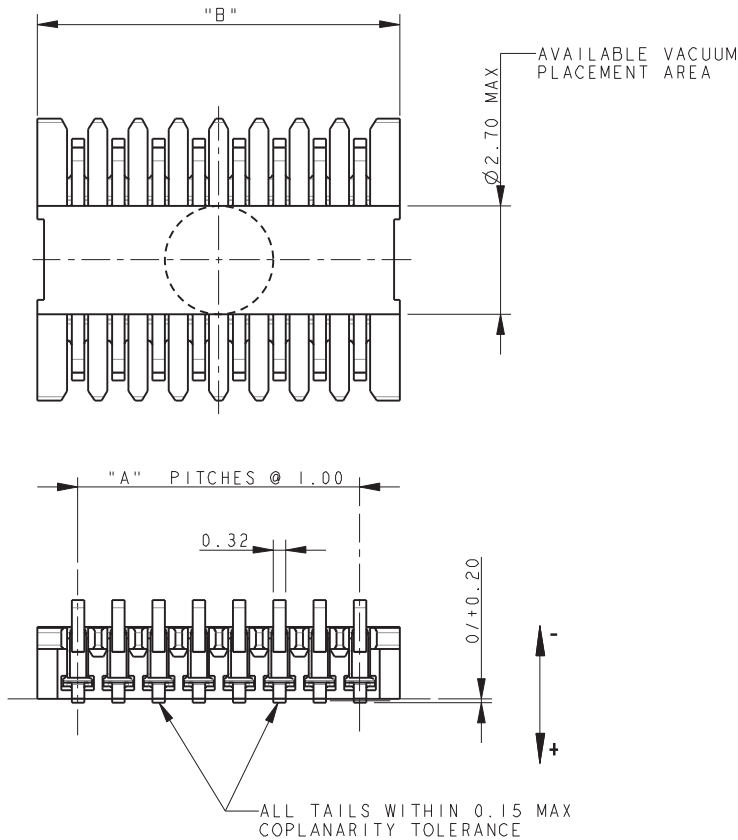

MATING CONDITION

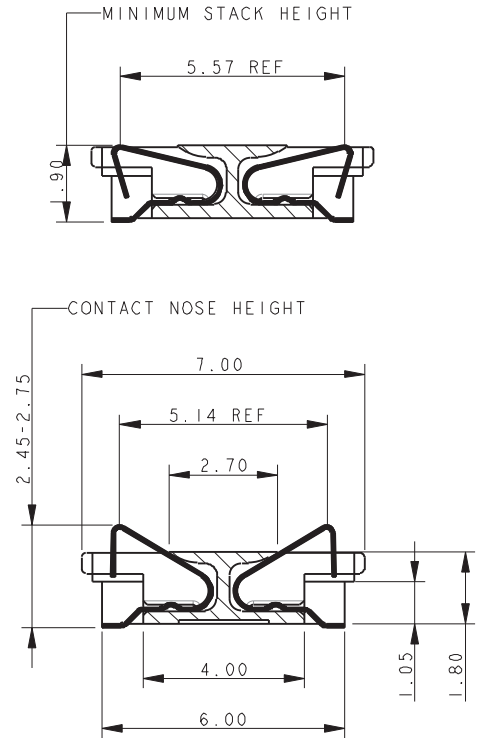

NOTES:

1. LAYOUT FOR MULTI-WAY DUAL ROW STACKING CONNECTOR (ELCO SERIES 9158).
2. FOR FULL PRODUCT SPECIFICATION REFER TO ELCO SPEC 201-01-073.
3. PART TO BE PACKED IN TAPE AND REEL. REFER TO PAGE 116 FOR DETAILS.
4. STACKER DESIGN TO ACCOMMODATE A PCB STACKING HEIGHT OF 1.90MM TO 2.10MM.
5. NO ALLOWANCE HAS BEEN MADE FOR SOLDER PASTE THICKNESS IN PCB STACKING HEIGHT.
6. GENERAL TOLERANCE ± 0.20 UNLESS OTHERWISE STATED.

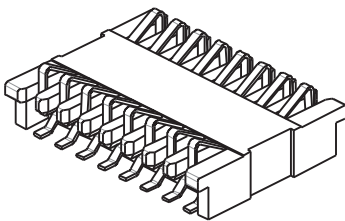

SMT PCB FOOTPRINT

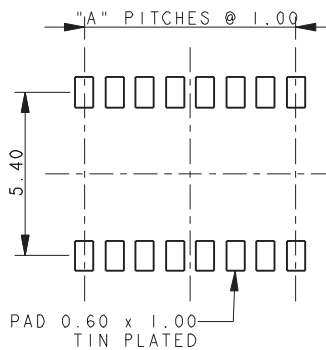

MATING PCB FOOTPRINT

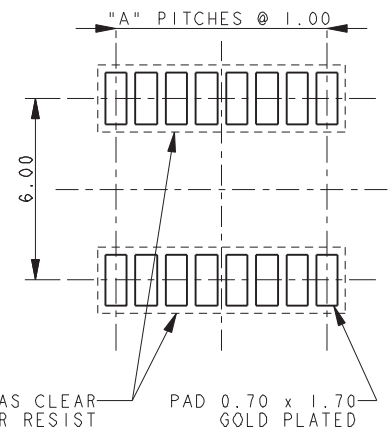

No of Positions	Part Number	A	B
16	00-9158-016-020-062	7	9.00
20	00-9158-020-020-062	9	11.00
24	00-9158-024-020-062	11	13.00
28	00-9158-028-020-062	13	15.00

Dual Row Stacker: BTB

00-9158

2.5MM DUAL ROW STACKER WITHOUT BOSSES

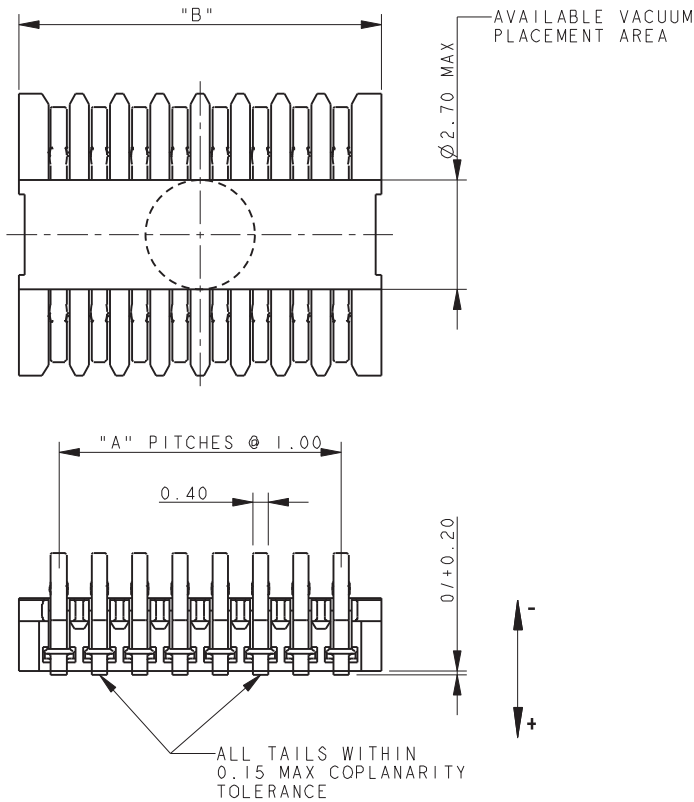

MATING CONDITION

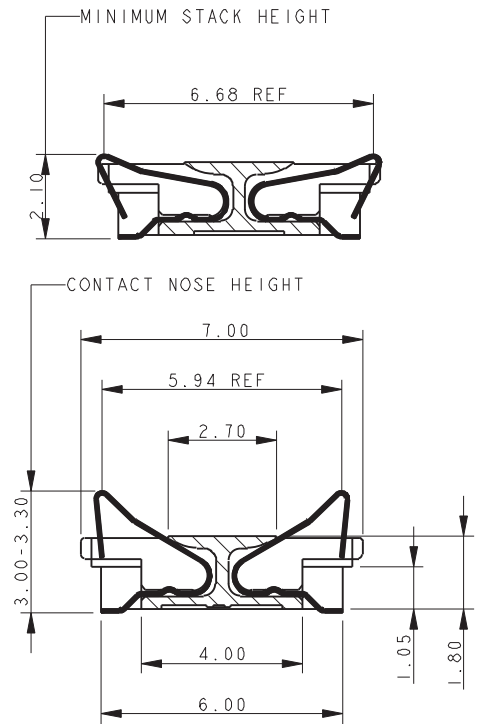

NOTES:

1. LAYOUT FOR MULTI-WAY DUAL ROW STACKING CONNECTOR (ELCO SERIES 9158).
2. FOR FULL PRODUCT SPECIFICATION REFER TO ELCO SPEC 201-01-073.
3. PART TO BE PACKED IN TAPE AND REEL. REFER TO PAGE 116 FOR DETAILS.
4. STACKER DESIGN TO ACCOMMODATE A PCB STACKING HEIGHT OF 2.10MM TO 2.70MM.
5. NO ALLOWANCE HAS BEEN MADE FOR SOLDER PASTE THICKNESS IN PCB STACKING HEIGHT.
6. GENERAL TOLERANCE ± 0.20 UNLESS OTHERWISE STATED.

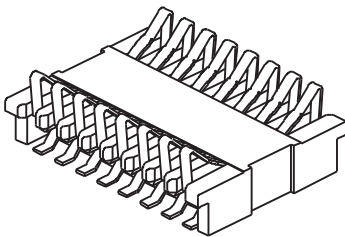

No of Positions	Part Number	A	B
16	00-9158-016-020-062	7	9.00
20	00-9158-020-020-062	9	11.00
24	00-9158-024-020-062	11	13.00
28	00-9158-028-020-062	13	15.00

SMT PCB FOOTPRINT

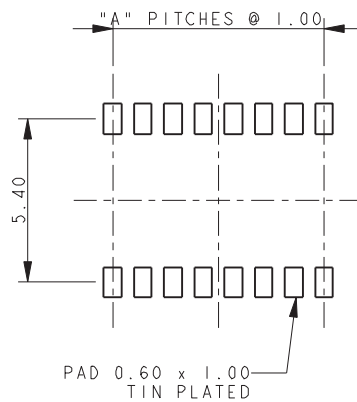

MATING PCB FOOTPRINT

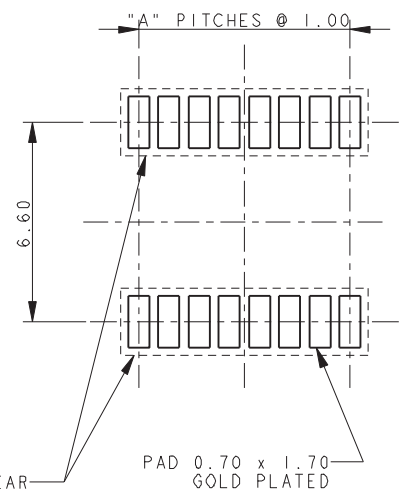

Dual Row Stacker: BTB

00-9158

3.0MM DUAL ROW STACKER WITHOUT BOSSES

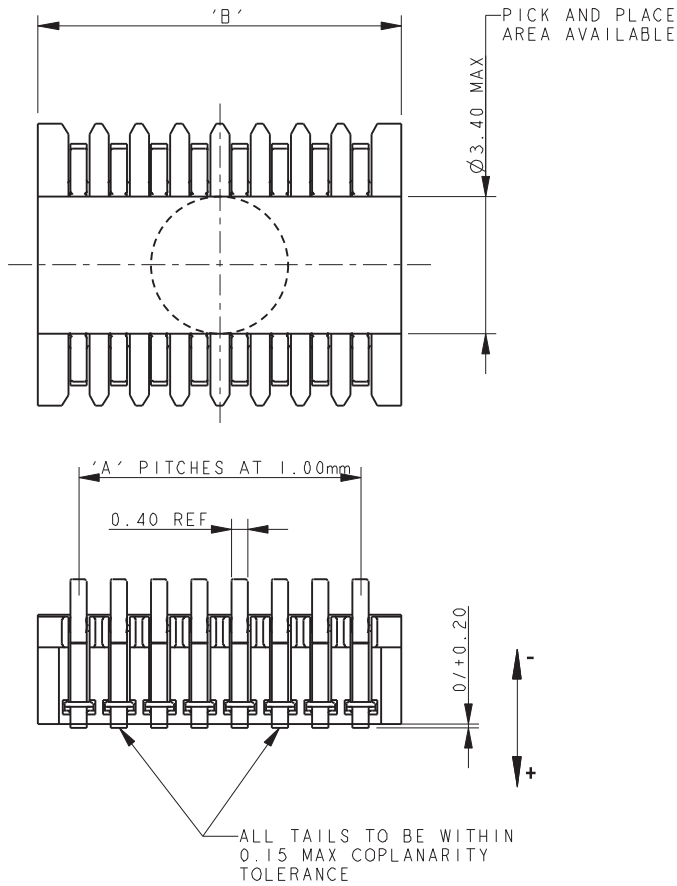

MATING CONDITION

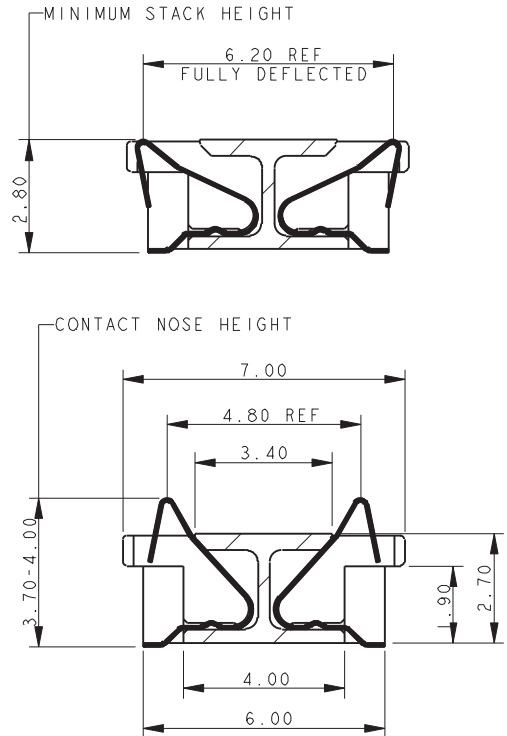

NOTES:

- LAYOUT FOR MULTI-WAY DUAL ROW STACKING CONNECTOR (ELCO SERIES 9158).
- FOR FULL PRODUCT SPECIFICATION REFER TO ELCO SPEC 201-01-073.
- PART TO BE PACKED IN TAPE AND REEL. REFER TO PAGE 116 FOR DETAILS.
- STACKER DESIGN TO ACCOMMODATE A PCB STACKING HEIGHT OF 2.80MM TO 3.30MM.
- NO ALLOWANCE HAS BEEN MADE FOR SOLDER PASTE THICKNESS IN PCB STACKING HEIGHT.
- GENERAL TOLERANCE ± 0.20 UNLESS OTHERWISE STATED.

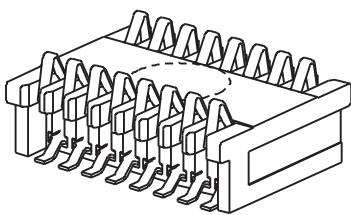

SMT PCB FOOTPRINT

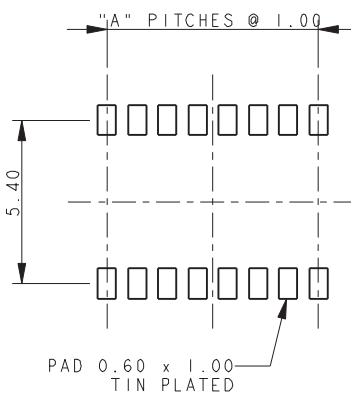

MATING PCB FOOTPRINT

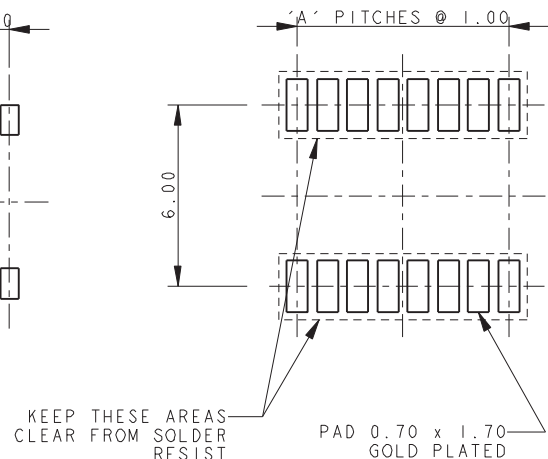

No of Positions	Part Number	A	B
16	00-9158-016-020-062	7	9.00
20	00-9158-020-020-062	9	11.00
24	00-9158-024-020-062	11	13.00
28	00-9158-028-020-062	13	15.00

Dual Row Stacker: BTB

00-9158

2.0MM DUAL ROW STACKER WITH BOSSES

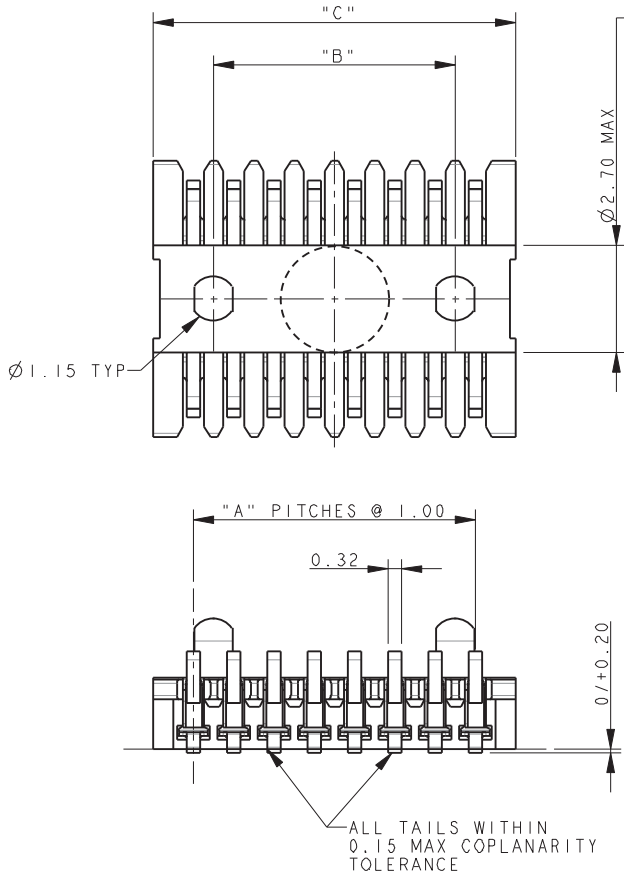

AVAILABLE VACUUM
PLACEMENT AREA

MATING CONDITION

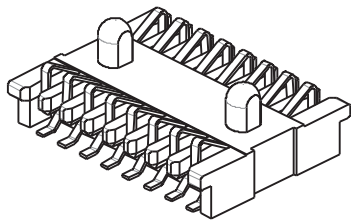
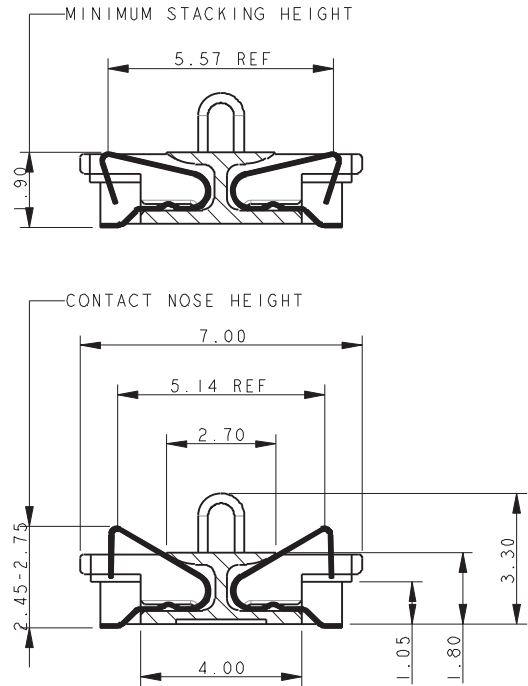

NOTES:

1. LAYOUT FOR MULTI-WAY DUAL ROW STACKING CONNECTOR (ELCO SERIES 9158).
2. FOR FULL PRODUCT SPECIFICATION REFER TO ELCO SPEC 201-01-073.
3. PART TO BE PACKED IN TAPE AND REEL. REFER TO PAGE 116 FOR DETAILS.
4. STACKER DESIGN TO ACCOMMODATE A PCB STACKING HEIGHT OF 1.90MM TO 2.10MM.
5. NO ALLOWANCE HAS BEEN MADE FOR SOLDER PASTE THICKNESS IN PCB STACKING HEIGHT.
6. GENERAL TOLERANCE ± 0.20 UNLESS OTHERWISE STATED.

SMT PCB FOOTPRINT

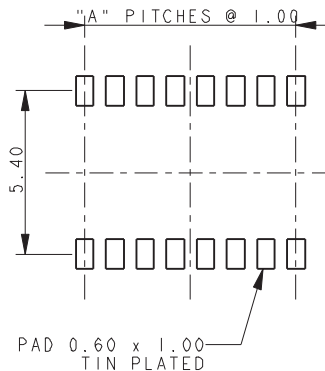

MATING PCB FOOTPRINT

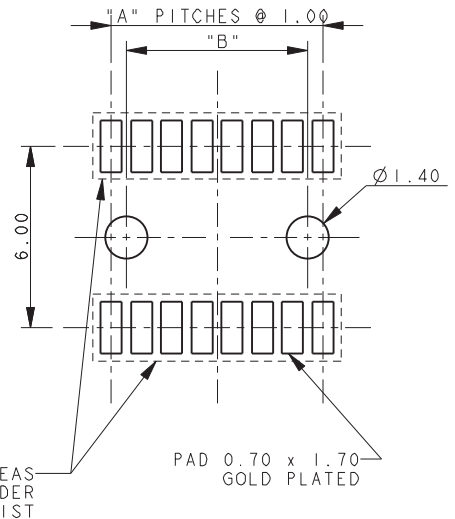

No of Positions	Part Number	A	B	C
16	00-9158-016-020-062	7	6.00	9.00
20	00-9158-020-020-062	9	8.00	11.00
24	00-9158-024-020-062	11	10.00	13.00
28	00-9158-028-020-062	13	12.00	15.00

Dual Row Stacker: BTB

00-9158

2.5MM DUAL ROW STACKER WITH BOSSES

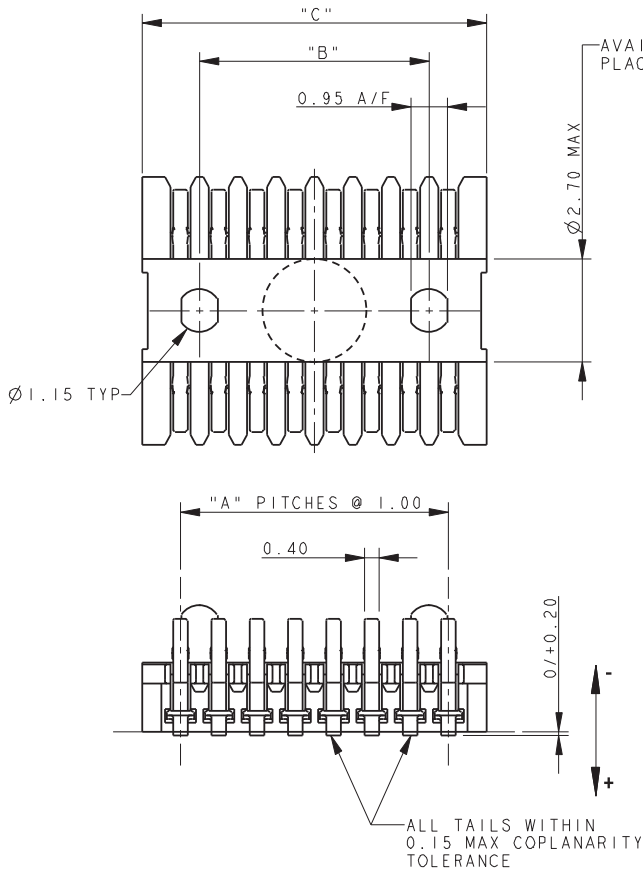

MATING CONDITION

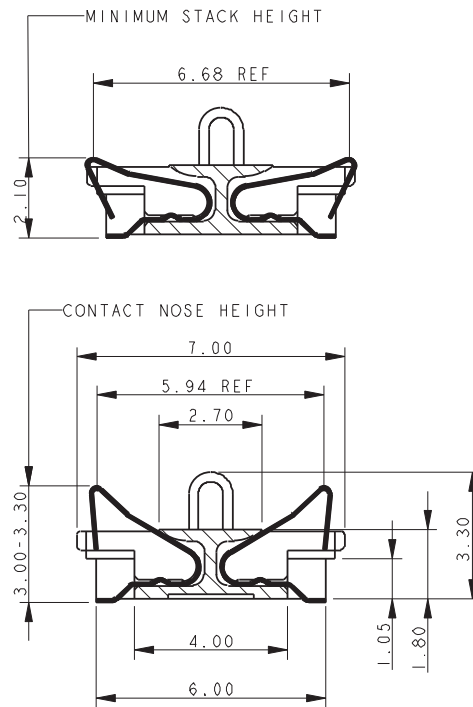

NOTES:

1. LAYOUT FOR MULTI-WAY DUAL ROW STACKING CONNECTOR (ELCO SERIES 9158).
2. FOR FULL PRODUCT SPECIFICATION REFER TO ELCO SPEC 201-01-073.
3. PART TO BE PACKED IN TAPE AND REEL. REFER TO PAGE 116 FOR DETAILS.
4. STACKER DESIGN TO ACCOMMODATE A PCB STACKING HEIGHT OF 2.10MM TO 2.70MM.
5. NO ALLOWANCE HAS BEEN MADE FOR SOLDER PASTE THICKNESS IN PCB STACKING HEIGHT.
6. GENERAL TOLERANCE ± 0.20 UNLESS OTHERWISE STATED.

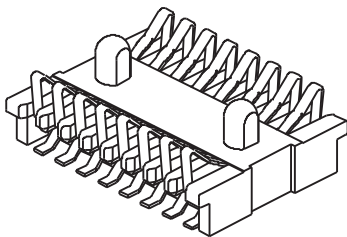

SMT PCB FOOTPRINT

MATING PCB FOOTPRINT

No of Positions	Part Number	A	B	C
16	00-9158-016-020-062	7	6.00	9.00
20	00-9158-020-020-062	9	8.00	11.00
24	00-9158-024-020-062	11	10.00	13.00
28	00-9158-028-020-062	13	12.00	15.00

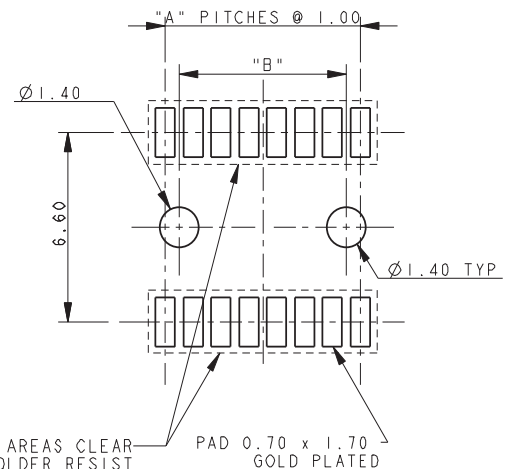
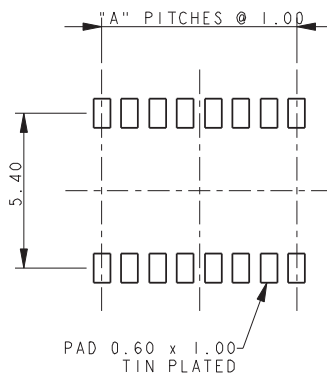

Dual Row Stacker: BTB

00-9158

3.0MM DUAL ROW STACKER WITH BOSSES

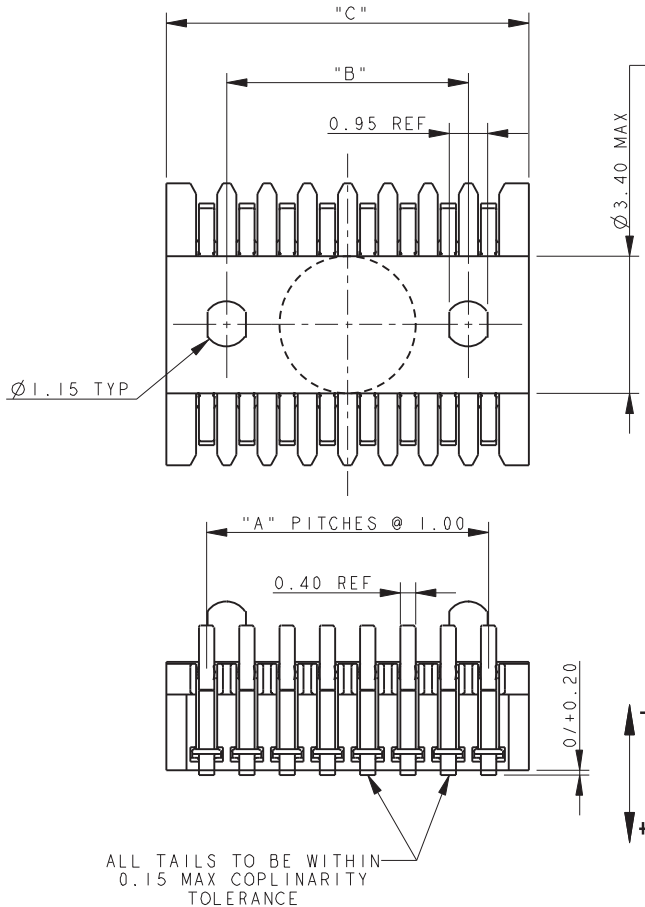

MATING CONDITION

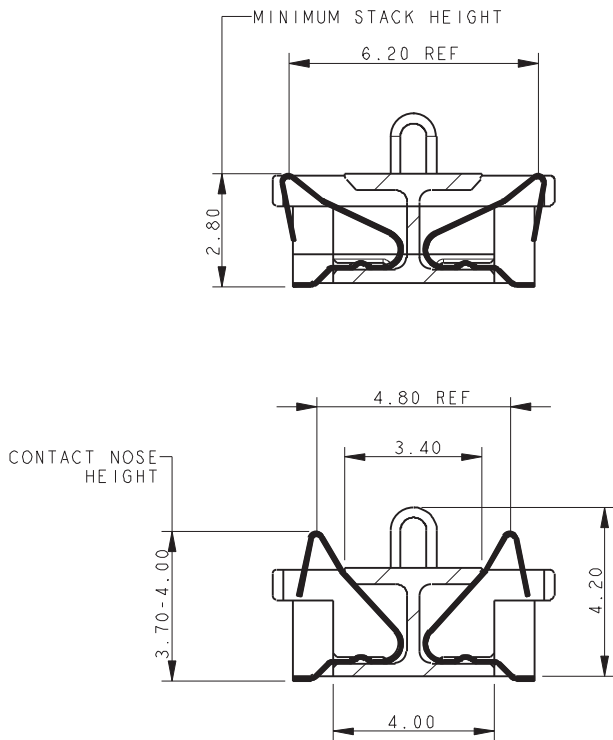

NOTES:

1. LAYOUT FOR MULTI-WAY DUAL ROW STACKING CONNECTOR (ELCO SERIES 9158).
2. FOR FULL PRODUCT SPECIFICATION REFER TO ELCO SPEC 201-01-073.
3. PART TO BE PACKED IN TAPE AND REEL. REFER TO PAGE 116 FOR DETAILS.
4. STACKER DESIGN TO ACCOMMODATE A PCB STACKING HEIGHT OF 2.80MM TO 3.30MM.
5. NO ALLOWANCE HAS BEEN MADE FOR SOLDER PASTE THICKNESS IN PCB STACKING HEIGHT.
6. GENERAL TOLERANCE ± 0.20 UNLESS OTHERWISE STATED.

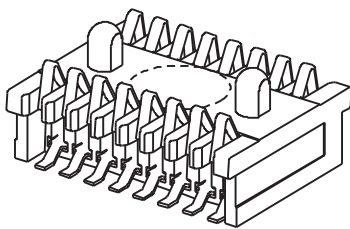

SMT PCB FOOTPRINT

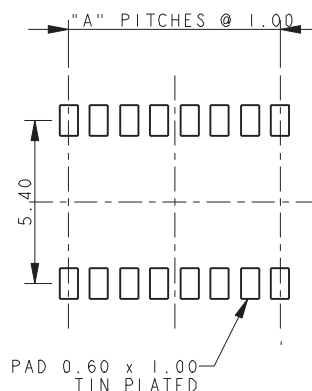

MATING PCB FOOTPRINT

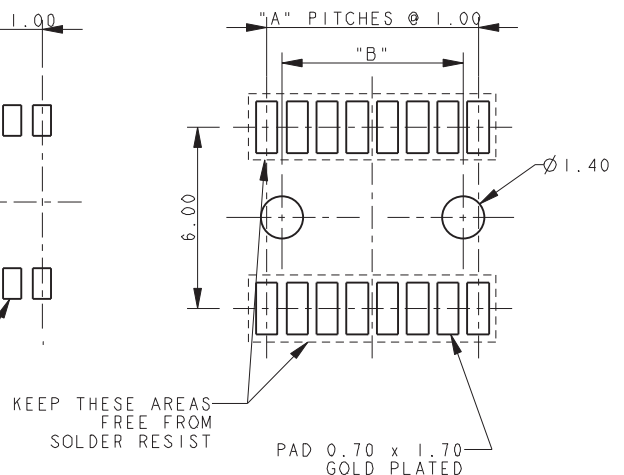

No of Positions	Part Number	A	B	C
16	00-9158-016-020-062	7	6.00	9.00
20	00-9158-020-020-062	9	8.00	11.00
24	00-9158-024-020-062	11	10.00	13.00
28	00-9158-028-020-062	13	12.00	15.00

LIMITS TO PCB MISALIGNMENT

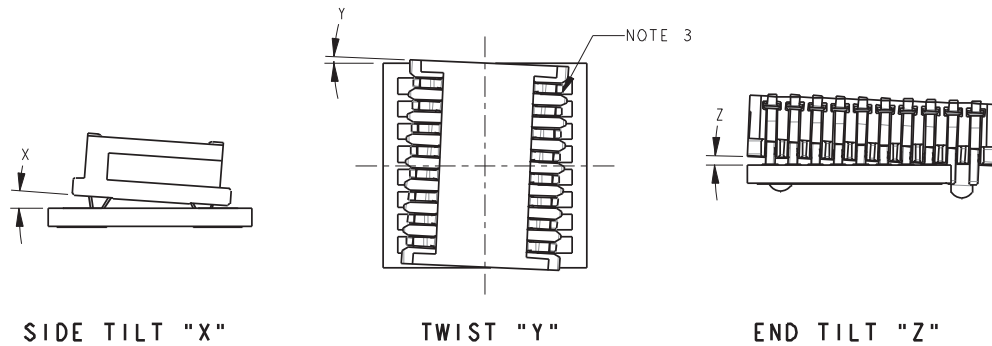

Code (See page 107)	Stack Height (Note 1)	Max Angle Degrees on Axis (Note 4)	Number of Ways			
			16	20	24	28
020	1.9mm to 2.1mm	X	2.0	2.0	2.0	2.0
		Y	3.5	3.5	3.5	3.5
		Z	2.0	1.5	1.0	1.0
025	2.1mm to 2.7mm	X	4.0	4.0	4.0	4.0
		Y	2.5	2.5	2.5	2.5
		Z	4.0	3.0	2.5	2.0
030	2.7mm to 3.3mm	X	4.0	4.0	4.0	4.0
		Y	2.5	2.5	2.5	2.5
		Z	3.5	2.5	2.0	2.0

NOTES:

1. PCB STACK HEIGHT (REF PAGE 109). THIS IS THE CONTROLLING LIMIT ON THE GAP BETWEEN THE TWO PCB FACES AT ANY POINT WHEN IN THE FINAL MATED POSITION.
2. NO ALLOWANCE HAS BEEN MADE FOR SOLDER PASTE THICKNESS IN PCB STACKING HEIGHT.
3. IT IS CRITICAL THAT ON ASSEMBLY THE CONTACT NOSES DO NOT STRAY OUTSIDE OF THE MATING PAD AREA IN THE FINAL MATED POSITION.
4. THE MAXIMUM MISALIGNMENT ABOUT ANY ONE AXIS IN DEGREES. SEE NOTES 1 AND 3.

PACKING DETAILS 9158 SOLO STACKER CONNECTORS

No of Positions	Stack Height	Bosses	Part Number	Tape Width	Reel Qty.
16	2.0	Yes	00-9158-016-020-0X1	16	1250
16	2.0	No	00-9158-016-020-0X2	16	1500
16	2.5	Yes	00-9158-016-025-0X1	16	1250
16	2.5	No	00-9158-016-025-0X2	16	1250
16	3.0	Yes	00-9158-016-030-0X1	16	1100
16	3.0	No	00-9158-016-030-0X2	16	1100
20	2.0	Yes	00-9158-020-020-0X1	24	1250
20	2.0	No	00-9158-020-020-0X2	24	1500
20	2.5	Yes	00-9158-020-025-0X1	24	1250
20	2.5	No	00-9158-020-023-0X2	24	1250
20	3.0	Yes	00-9158-020-030-0X1	24	1100
20	3.0	No	00-9158-020-030-0X2	24	1100
24	2.0	Yes	00-9158-024-020-0X1	24	1250
24	2.0	No	00-9158-024-020-0X2	24	1500
24	2.5	Yes	00-9158-024-025-0X1	24	1250
24	2.5	No	00-9158-024-025-0X2	24	1250
24	3.0	Yes	00-9158-024-030-0X1	24	1100
24	3.0	No	00-9158-024-030-0X2	24	1100
28	2.0	Yes	00-9158-028-020-0X1	24	1250
28	2.0	No	00-9158-028-020-0X2	24	1500
28	2.5	Yes	00-9158-028-025-0X1	24	1250
28	2.5	No	00-9158-028-025-0X2	24	1250
28	3.0	Yes	00-9158-028-030-0X1	24	1100
28	3.0	No	00-9158-028-030-0X2	24	1100

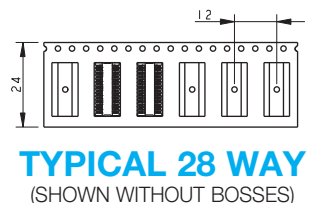
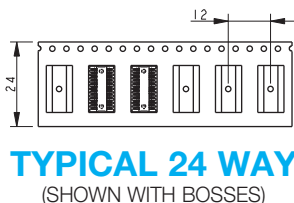
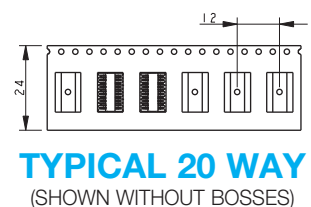
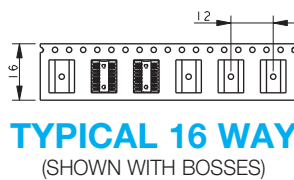
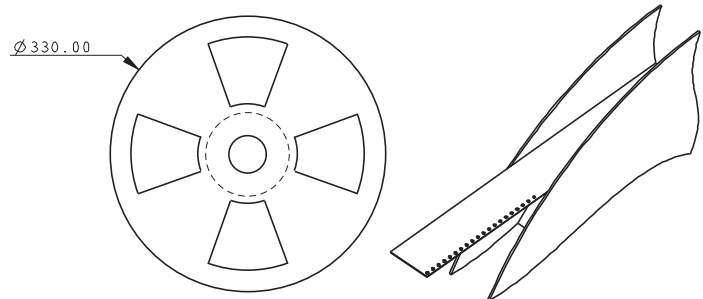

单击下面可查看定价，库存，交付和生命周期等信息

[>>AVX](#)