

Standard 26-28 AWG: WTB

00-9175



The 917X series of surface mount Insulation Displacement Connectors (IDC) were developed to meet the harsh automotive and industrial market applications for connecting individual wires directly to a PCB ranging from 14 AWG to 28 AWG. This industry proven contact system has been tested to automotive levels of shock, vibration, and temperature cycling to prove their reliability and robustness. The simplicity of inserting a wire into the connector with a small tool allows a wide range of devices to be connected to the PCB without soldering. In SSL applications specifically, these connectors are used to bring power and signal onto the PCB or are used to daisy chain multiple boards together in a long string. While the IDC contact provides a gas-tight connection to conductor of the wire, the housing has been designed to grab the insulation of the wire to provide a positive strain relief even in the harshest conditions. In case of repair, the wires can be removed and replaced up to three times.

The 9175 series accepts 26 AWG to 28 AWG wires with an insulation diameter ranging from 0.7mm to 1.0mm. These single contact connectors support a 1 amp current rating and have a split SMT tail design to provide maximum stability on the PCB. Available in a 2p and 3p configuration, these connectors can be end stackable for higher pin counts.

APPLICATIONS

- Connecting discrete wire components directly to the PCB
- Bringing power and signals onto a PCB
- Daisy chaining PCB's together to create a continuous string of boards
- Application Notes: refer to 201-01-124

FEATURES AND BENEFITS

- IDC contact provides a gas-tight connection to the PCB for long term reliability
- Connector housing captures the wire insulation for positive strain relief
- Tested to automotive levels on shock, vibration and temperature cycling for reliability
- Low and high volume assembly tools to match production volumes
- Reduced total applied cost versus solder or crimp processes
- High temperature insulator capable to 260 degrees C reflow soldering processes

ELECTRICAL

- Current Rating: 1 Amp / Contact
- Voltage Rating: 150 VAC

ENVIRONMENTAL

- Operating Temperature: -40°C to +125°C

MECHANICAL

- Insulator Material: Nylon 46: UL94V0
- Contact Material: Phosphor Bronze
- Plating: Tin over Nickel
- Durability: 3 Cycles

HOW TO ORDER

00	9175	00X									
Prefix	Series	Number of Ways									
		<table border="1"> <thead> <tr> <th>Code</th> <th>No of Ways</th> <th>Details</th> </tr> </thead> <tbody> <tr> <td>002</td> <td>2</td> <td>Page 4</td> </tr> <tr> <td>003</td> <td>3</td> <td>Page 5</td> </tr> </tbody> </table>	Code	No of Ways	Details	002	2	Page 4	003	3	Page 5
Code	No of Ways	Details									
002	2	Page 4									
003	3	Page 5									

00X	X	06									
Wire Gauge Size	Insulator Color	Plating Option									
	9 = UL White 8 = UL Black Special Order	06 = Pure Tin all over									
<table border="1"> <thead> <tr> <th>Code</th> <th>Accepted Wire Gauge</th> <th>Wire Insulation</th> </tr> </thead> <tbody> <tr> <td>001</td> <td>28 Gauge Solid or Stranded</td> <td>Ø 0.70 to Ø 1.00</td> </tr> <tr> <td>002</td> <td>26 Gauge Solid or Stranded</td> <td>Ø 0.70 to Ø 1.00</td> </tr> </tbody> </table>	Code	Accepted Wire Gauge	Wire Insulation	001	28 Gauge Solid or Stranded	Ø 0.70 to Ø 1.00	002	26 Gauge Solid or Stranded	Ø 0.70 to Ø 1.00		
Code	Accepted Wire Gauge	Wire Insulation									
001	28 Gauge Solid or Stranded	Ø 0.70 to Ø 1.00									
002	26 Gauge Solid or Stranded	Ø 0.70 to Ø 1.00									



CONNECTOR/TOOLING PART NUMBER MATRIX

SERIES 9175 IDC					HAND INSERTION TOOLING*			ACCESSORY CAPS	
AWG	Wire Insulation	Positions	Color	Part Number	Plastic (medium volume)	Metal (high volume)	Mass Termination	Though Wire	Wire Stop
26	Ø 0.7 - 1.0	2p	White	009175002002906	069175701601000	069175701701000	069175701701002	609175002010100	609175002010199
26	Ø 0.7 - 1.0	2p	Black	009175002002806	069175701601000	069175701701000	069175701701002	609175002010000	609175002010099
26	Ø 0.7 - 1.0	3p	White	009175003002906	069175701601000	069175701701000	069175701701003	609175003010100	609175003010199
26	Ø 0.7 - 1.0	3p	Black	009175003002806	069175701601000	069175701701000	069175701701003	609175003010000	609175003010099
28	Ø 0.7 - 1.0	2p	White	009175002001906	069175701601000	069175701701000	069175701701002	609175002010100	609175002010199
28	Ø 0.7 - 1.0	2p	Black	009175002001806	069175701601000	069175701701000	069175701701002	609175002010000	609175002010099
28	Ø 0.7 - 1.0	3p	White	009175003001906	069175701601000	069175701701000	069175701701003	609175003010100	609175003010199
28	Ø 0.7 - 1.0	3p	Black	009175003001806	069175701601000	069175701701000	069175701701003	609175003010000	609175003010099

* Hand Insertion Tooling - Universal Hand Tool 067000773001000; Consult Application Notes 201-01-124

Certification: UL File #E90723

26-28 AWG 2 WAY IDC CONNECTOR

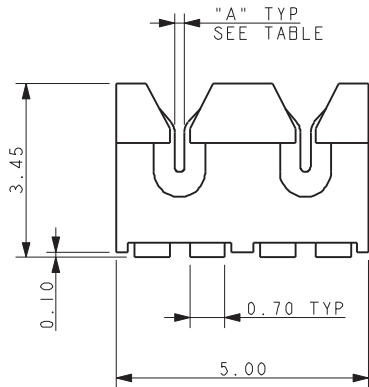
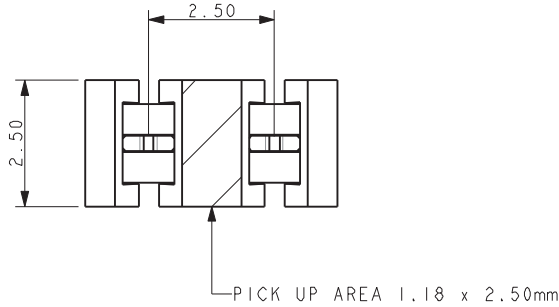

Code	Wire Gauge	A
001	28AWG	0.20
002	26AWG	0.28

- NOTES:
- CONNECTOR FOR IDC WIRE TO BOARD CONNECTION.
 - CONTACT MATERIAL: PHOSPHOR BRONZE.
INSULATION MATERIAL: HIGH TEMPERATURE NYLON 46.
COLOR REFER TO PAGE 3.
 - CONNECTOR DESIGNED TO ACCEPT 26 AND 28 GAUGE SOLID OR STRANDED WIRE.
 - ALL DIMENSIONS FOR REFERENCE UNLESS OTHERWISE STATED.
 - FOR FULL PRODUCT SPECIFICATION ON STANDARD CONNECTORS REFER TO ELCO SPEC 201-01-100, UL COMPONENTS REFER TO ELCO SPEC 201-01-100UL.
 - APPLICATION NOTES 201-01-124.
 - FOR UL PRODUCT CODES UL REFERENCE 390723 (US AND CANADA).
 - CONNECTOR OUTLINE.
 - ALL DIMENSIONS ± 0.20 UNLESS TOLERANCE SPECIFIED.

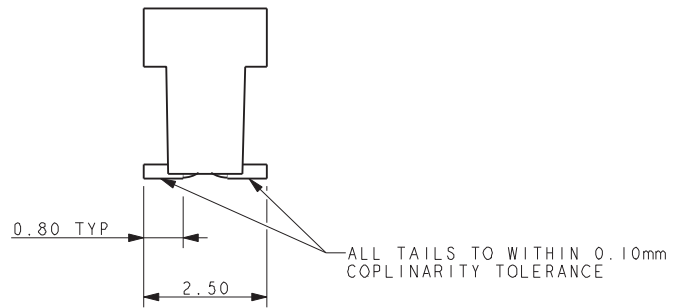

SMT PCB LAYOUT

PURE TIN PADS

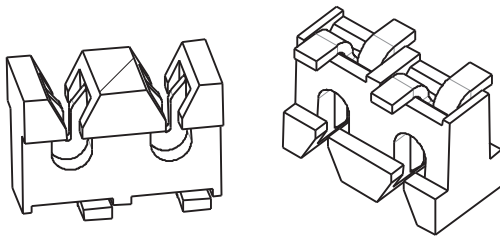
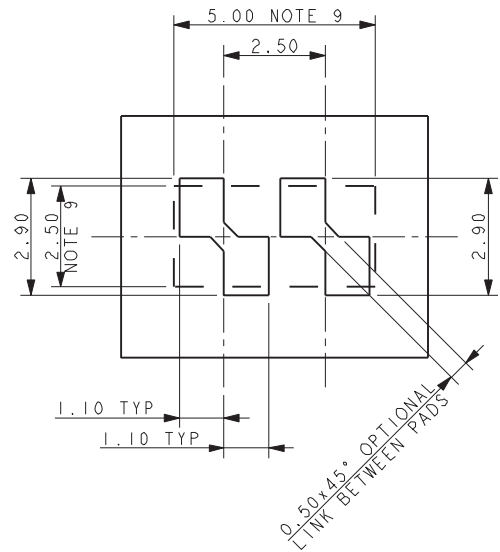

PACKING DETAILS

REEL QTY	2000
LEADER	500MM
TRAILER	500MM

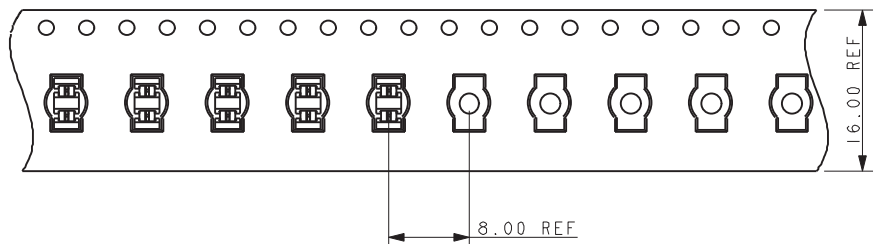
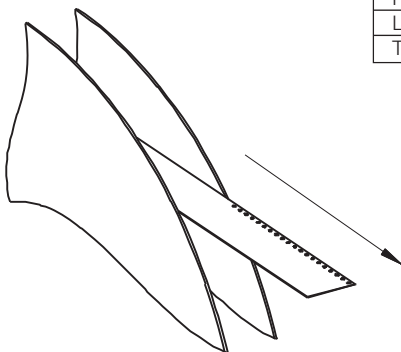

26-28 AWG 3 WAY IDC CONNECTOR

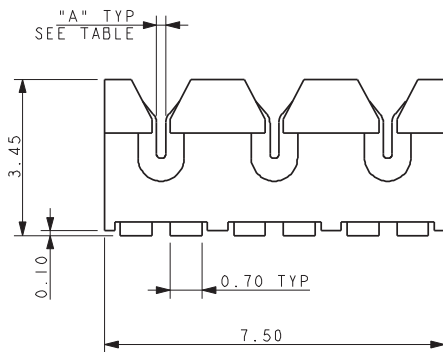
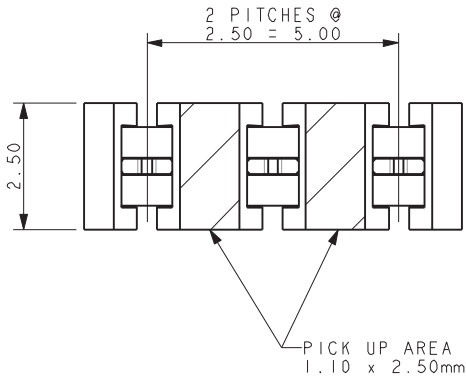

Code	Wire Gauge	A
001	28AWG	0.20
002	26AWG	0.28

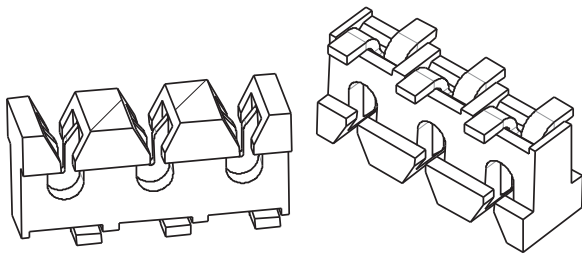

PACKING DETAILS

REEL QTY	2000
LEADER	500MM
TRAILER	500MM

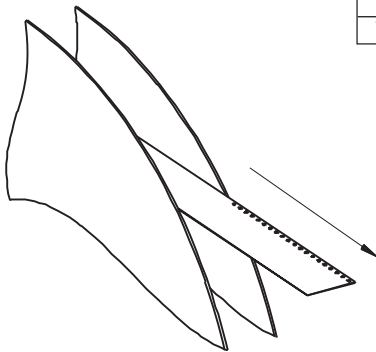

NOTES:

- CONNECTOR FOR IDC WIRE TO BOARD CONNECTION.
- CONTACT MATERIAL: PHOSPHOR BRONZE.
INSULATION MATERIAL: HIGH TEMPERATURE NYLON 46.
COLOR REFER TO PAGE 3.
- CONNECTOR DESIGNED TO ACCEPT 26 AND 28 GAUGE SOLID OR STRANDED WIRE.
- ALL DIMENSIONS FOR REFERENCE UNLESS OTHERWISE STATED.
- FOR FULL PRODUCT SPECIFICATION ON STANDARD CONNECTORS REFER TO ELCO SPEC 201-01-100, UL COMPONENTS REFER TO ELCO SPEC 201-01-100UL.
- APPLICATION NOTES 201-01-124.
- FOR UL PRODUCT CODES UL REFERENCE 390723 (US AND CANADA).
- CONNECTOR OUTLINE.
- ALL DIMENSIONS ± 0.20 UNLESS TOLERANCE SPECIFIED.

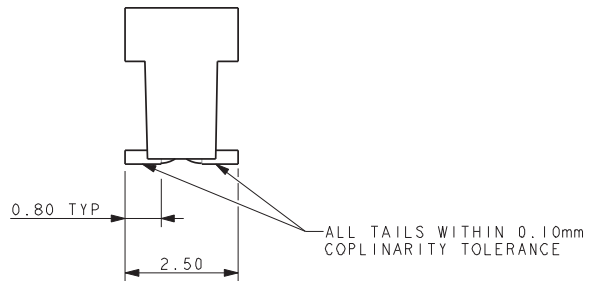

SMT PCB LAYOUT

PURE TIN PADS

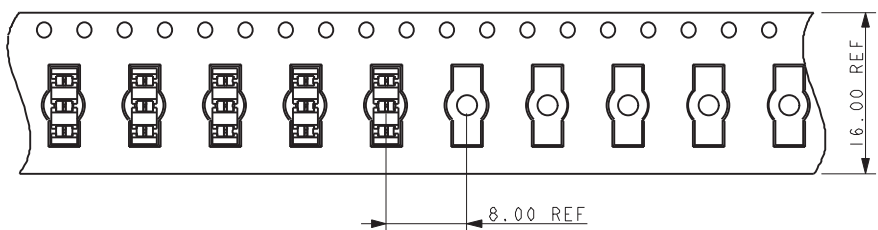
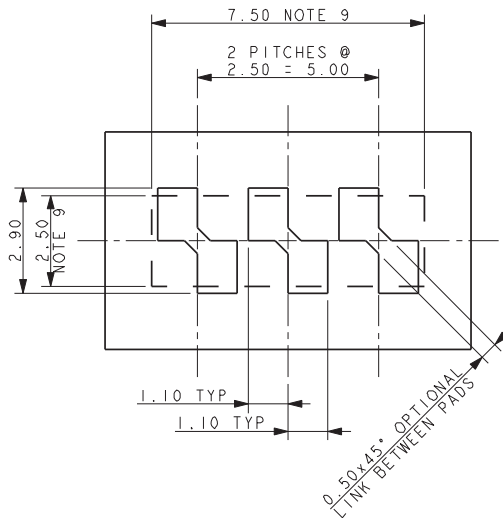

60-9175-00X-010-X00

ACCESSORY CAP – THROUGH WIRE

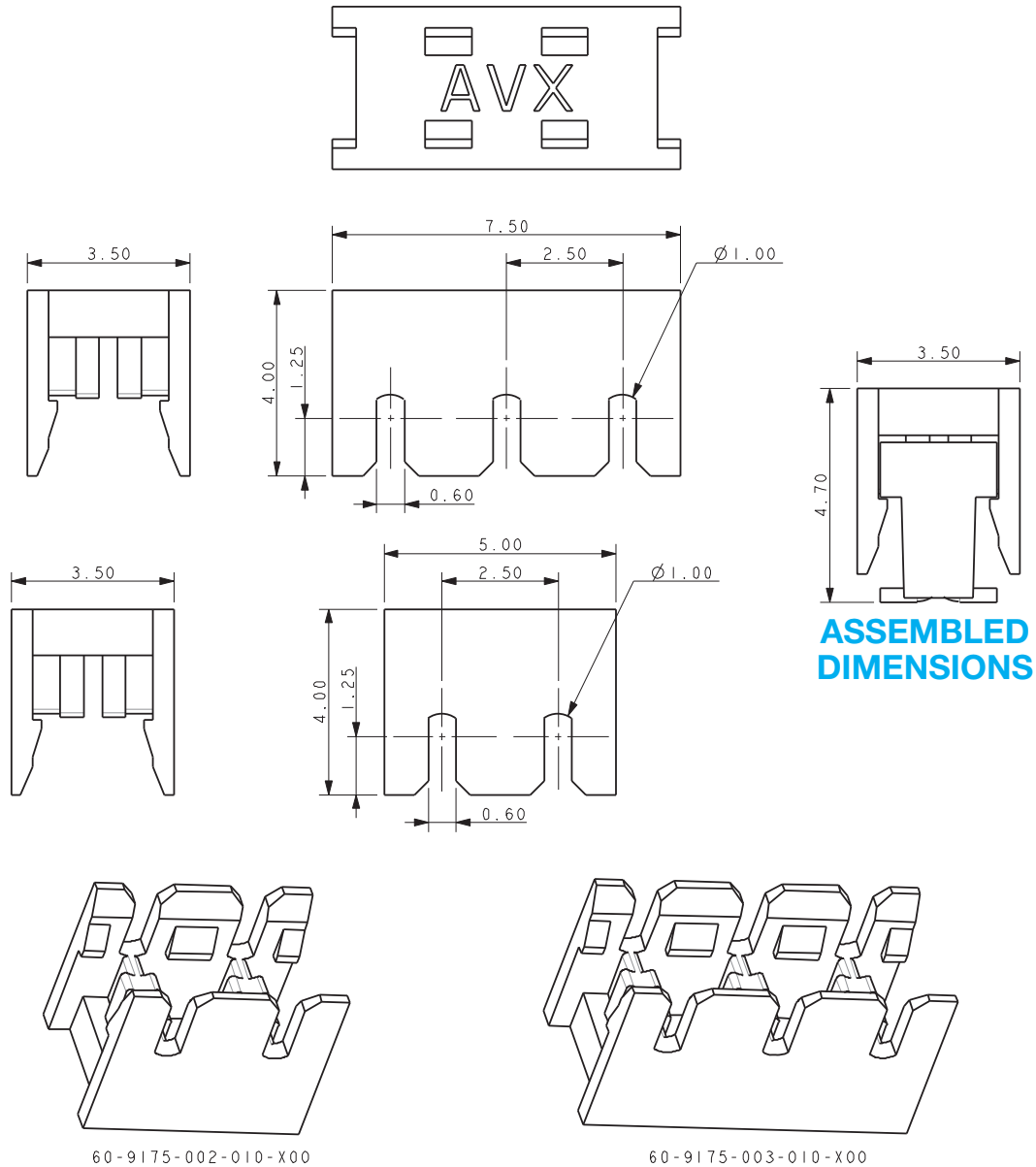

NOTES:

1. CAP FOR IDC WIRE TO BOARD CONNECTION, 2 AND 3 WAY, THROUGH WIRE.
2. THROUGH WIRE CAP CAN BE USED AT ANY POSITION ALONG A WIRE.
3. FOR USE WITH STANDARD 9175 IDC CONNECTORS
4. CAP MATERIAL: GLASS FILLED NYLON 46, FOR COLORS SEE PAGE 3.
5. CAPS DESIGNED TO ACCOMMODATE WIRES WITH INSULATION UP TO 1.00MM DIAMETERS.
6. GENERAL TOLERANCE ± 0.20 .
7. PACKED IN BAGS, 1000 PIECES PER BAG.
8. ALL DIMENSIONS ± 0.20 UNLESS TOLERANCE SPECIFIED.

60-9175-00X-0XX-010-X99 ACCESSORY CAP – WIRE STOP

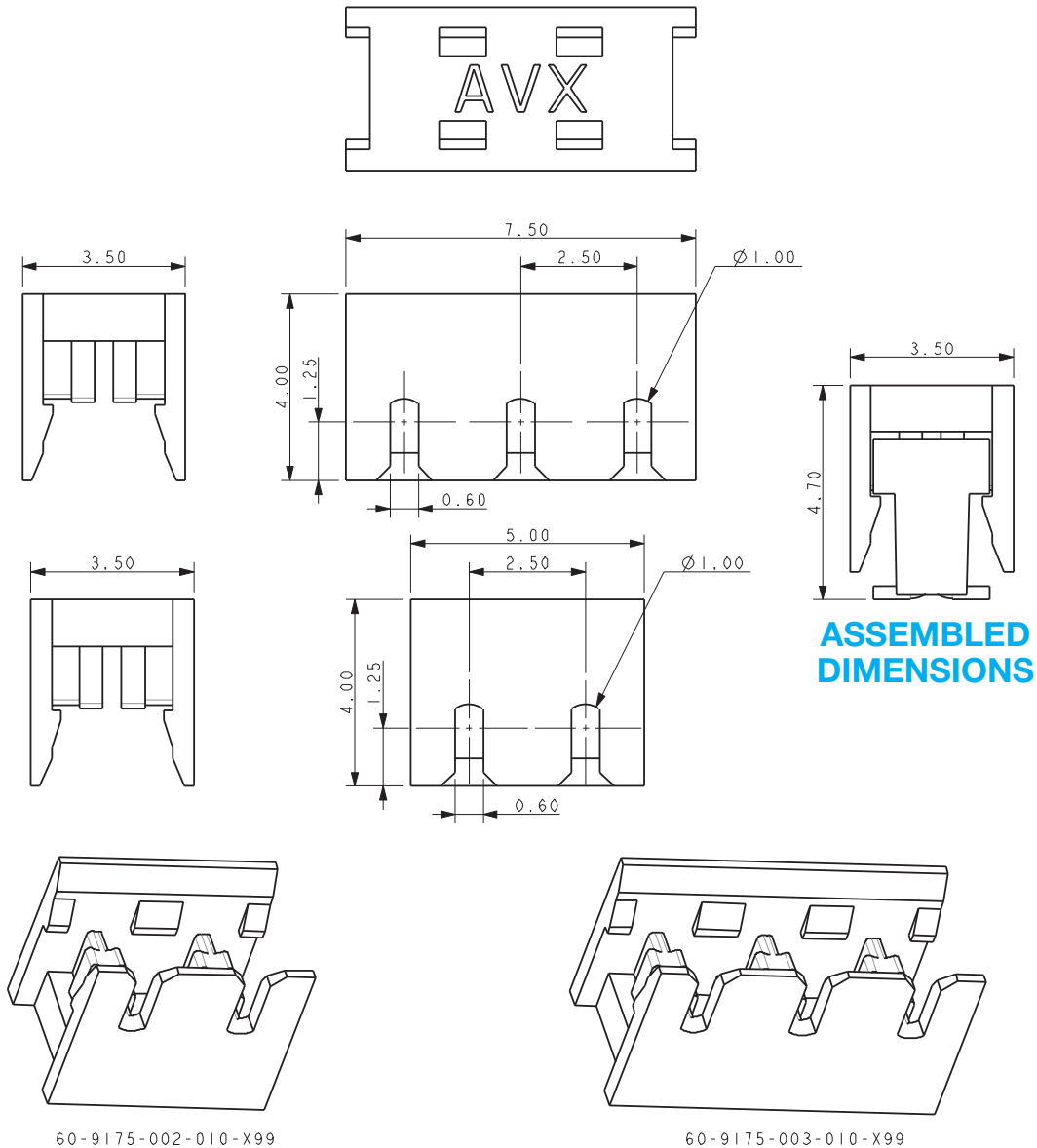

NOTES:

1. CAP FOR IDC WIRE TO BOARD CONNECTION, 2 AND 3 WAY, WIRE STOP.
2. WIRE STOP CAP FOR USE AT WIRE ENDS, STOP FACE PROTECTS THE WIRE ENDS.
3. FOR USE WITH STANDARD 9175 IDC CONNECTORS
4. CAP MATERIAL: GLASS FILLED NYLON 46, FOR COLORS SEE PAGE 3.
5. CAPS DESIGNED TO ACCOMMODATE WIRES WITH INSULATION UP TO 1.00MM DIAMETERS.
6. GENERAL TOLERANCE ± 0.20 .
7. PACKED IN BAGS, 1000 PIECES PER BAG.
8. ALL DIMENSIONS ± 0.20 UNLESS TOLERANCE SPECIFIED.

HAND INSERTION TOOLING SINGLE WIRE INSERTION TOOL FOR 26/28 GAUGE WIRE

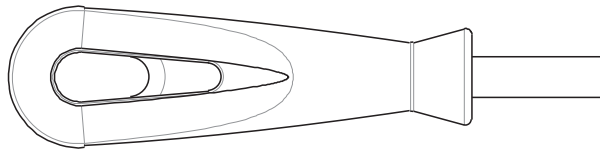

UNIVERSAL HANDLE

Details	Tool Part Number
6.35 A/F HEX BIT HOLDER	06-7000-7730-01-000

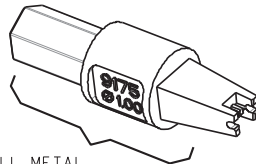

ALL METAL

HIGH PRODUCTION Metal

Max Insulation Dia	Tool Part Number
∅ 1.00	06-9175-7017-01-000

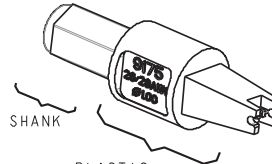

METAL SHANK

PLASTIC

MEDIUM PRODUCTION Metal/Plastic

Max Insulation Dia	Tool Part Number
∅ 1.00	06-9175-7016-01-000

CLEARANCE AREA ON PCB FOR HAND TOOLING

2 WAY

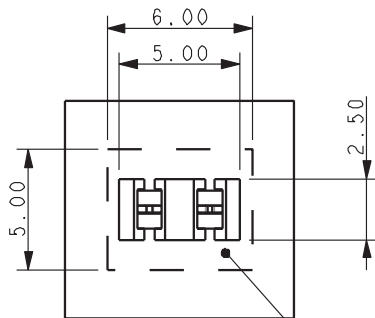

AREA TO BE KEPT CLEAR FOR TOOLING

3 WAY

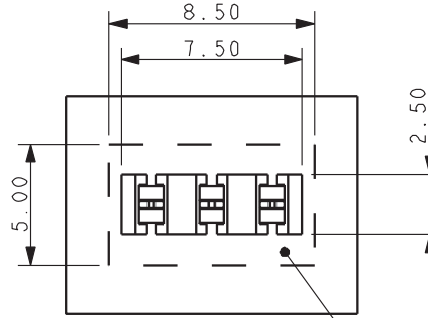

AREA TO BE KEPT CLEAR FOR TOOLING

INSERTION TOOLING REQUIRES HAND PRESS WITH FLAT ROCK PLATES

2 WAY TOOL

TOOL NUMBER 06-9175-7017-01-002

SKETCH SHOWS PCB RESTRICTED AREAS FOR ASSEMBLY TOOLING

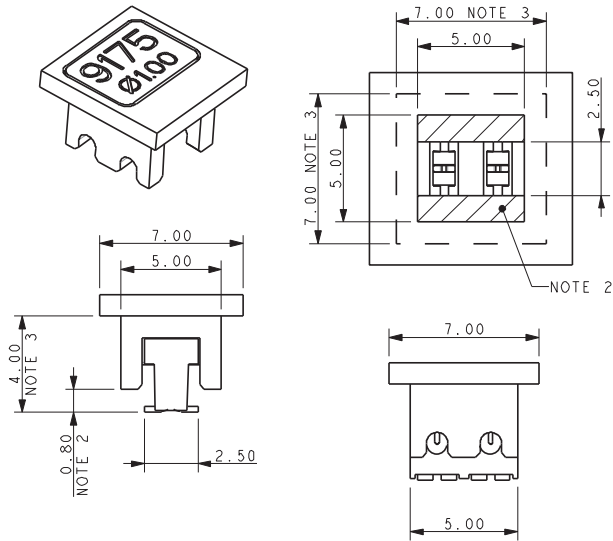

3 WAY TOOL

TOOL NUMBER 06-9175-7017-01-003

SKETCH SHOWS PCB RESTRICTED AREAS FOR ASSEMBLY TOOLING

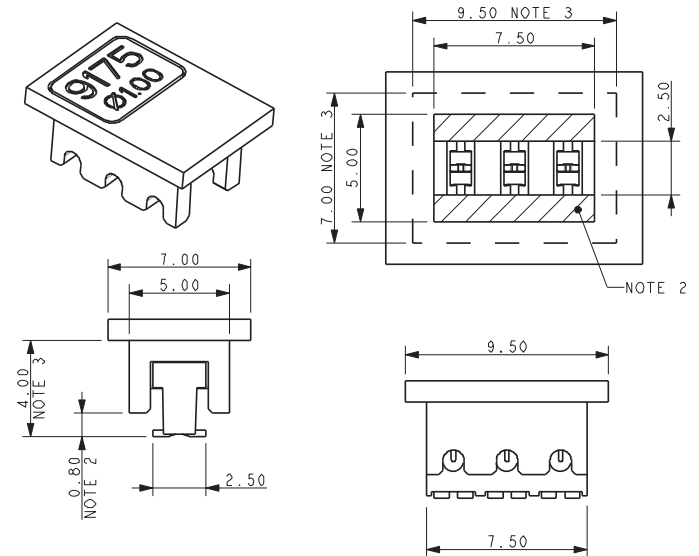

NOTES:

1. DIMENSIONS SHOWN ARE REFERENCE DIMENSIONS.
2. MAXIMUM COMPONENT HEIGHT 0.80MM IN THIS AREA.
3. MAXIMUM COMPONENT HEIGHT 4.00MM IN THIS AREA.
4. THE SAME RESTRICTIONS APPLY TO ALL WIRE INSULATION DIAMETERS.

ASSEMBLED CONNECTOR

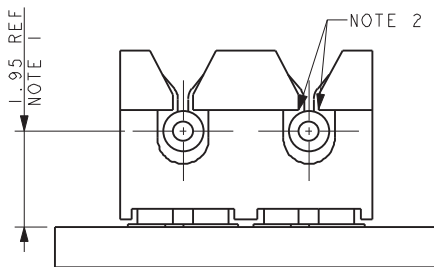

STANDARD CONNECTOR

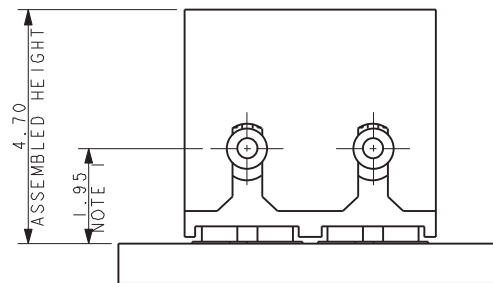

CONNECTOR WITH CAP

NOTES:

1. ASSEMBLED HEIGHTS INCLUDE A 0.10MM ALLOWANCE FOR PAD AND SOLDER THICKNESS, NO ALLOWANCE HAS BEEN MADE FOR ANY SOLDER RESIST OR OTHER FEATURES.
2. WHEN THE WIRE IS ASSEMBLED THE INSULATION SHOULD BE TRAPPED BY THESE EDGES.

单击下面可查看定价，库存，交付和生命周期等信息

[>>AVX](#)